



FRIEND

Flow Regimes from International Experimental and Network Data

Projects H-5-5 (IHP IV) and 1.1 (IHP V)

Third report : 1994-1997



Cemagref
EDITIONS

FRIEND

Flow Regimes from International Experimental and Network Data

Projects H-5-5 and 1.1

Projets H-5-5 et 1.1

Third report : 1994 - 1997

Troisième rapport : 1994 - 1997

June 1997

Coordinated by the FRIEND Report Committee (FRC)

Abel AFOUDA (Groupe AOC)

Alan GUSTARD (NEF Group)

Simon MKHANDI (SADC Group)

Guy OBERLIN (Groupe AMHY)

**Edition prepared by the panel of Authors and Chapter Editors,
and finalized by Guy OBERLIN, Report Editor, and Elisabeth DESBOS
(Division Hydrologie-Hydraulique, Cemagref Lyon)**

supported by the FRIEND Groups, the GIS AMHY, the GIP HydroSystèmes, Cemagref, et alter

© Copyright 1997 by Cemagref. All rights reserved. No part of this publication may be reproduced, stored in a retrieval system, or transmitted, in any form or by any means, electronic, mechanical photocopying, recording or otherwise without the prior written permission of the publisher.

First published 1997. ISBN 2-85362-475-7. Dépôt légal : 3^e trimestre 1997. Printed by : LOUIS JEAN, 05003 Gap Cedex, France. Mail order sales : Publi-Trans BP 22, 91167 Longjumeau Cedex 9, France, Tel+33 1 69 10 85 85. Fax+33 1 69 10 85 84. Sales through booksellers : TEC et Doc, 14 rue de Provigny, 94236 Cachan Cedex 9, France, Tel 33 1 47 40 67 00 – Price : 390 FF

Preface

A. Szöllösi-Nagy

FRIEND (Flow Regimes from International Experimental and Network Data) began in 1985 based on an idea by Dr John Rodda, then Secretary General and now President of IAHS. At the instigation of a few European hydrologists, a group of European countries started sharing data and skills with a view to developing research activities on flow regimes at a regional scale with the aim of gaining a better understanding of the spatial and temporal variability of hydrological regimes. By 1989, thirteen countries had taken part with substantial benefits in regional-scale analysis of hydrological regimes and the detection of trends due to climate change and human impact. In view of the continued interest shown by the Member States of UNESCO in the FRIEND project it was decided by the IHP Intergovernmental Council to include it in the plan for the Fifth Phase of the International Hydrological Programme (Theme 1: Project 1.1).

The encouraging results obtained, presented at the first FRIEND Conference in Bolkesjø, Norway, 1989, combined with the flexibility of the project organization and implementation, led to the establishment of other FRIEND projects in the Mediterranean region (FRIEND AMHY), Africa, South-East Asia and the Nile region. FRIEND projects are structured around four-year periods concluded by a Conference where the main results are presented and discussed and eventually published.

Since 1985, a great deal of progress has been made in the understanding of spatial and temporal variability of hydrological regimes. The FRIEND project has also developed an important training component which contributes to improving the skills of hydrologists and to the strengthening of the capacity of national hydrological services to assess their water resources.

FRIEND today represents a network of expertise covering Western and Eastern Europe, the Mediterranean region, Africa, Asia, the Pacific and will soon include Latin America.

This publication is being issued in connection with the third FRIEND Conference which is taking place in Postojna, Slovenia, 1-4 October 1997. It includes the main research results obtained during the period 1993-1997 by FRIEND Northern Europe and FRIEND AMHY as well as contributions from the Southern Africa and Western/Central Africa Groups.

I would like to express my thanks to all the hydrologists who have contributed to the success of the FRIEND project, and, in particular, to Dr Guy Oberlin, Coordinator of the FRIEND/AMHY Group who edited this Report, on behalf of the FRIEND Report Committee.

ooooo

Préface

A. Szöllösi-Nagy

FRIEND (Flow Regimes from International Experimental and Network Data) a débuté en 1985, à partir d'une idée de John Rodda, alors Secrétaire Général et maintenant Président de l'AISH. A l'initiative de quelques hydrologues, un groupe de pays européens se lança dans des échanges de données et de méthodologies, en vue de développer des actions de recherches sur les régimes d'écoulement à l'échelle régionale, et dans le but de mieux comprendre les variabilités spatiales et temporelles de ces régimes hydrologiques. Vers 1989, treize pays avaient participé, et avec des progrès significatifs en matière d'analyses régionales des régimes et de détection des tendances induites par les changements climatiques ou les actions anthropiques. Compte tenu de l'intérêt persistant manifesté par les pays membres de l'UNESCO vis à vis de ce projet FRIEND, il a été décidé par le Conseil Intergouvernemental du PHI de l'intégrer dans la cinquième phase de ce Programme Hydrologique International (Thème 1 : Projet 1.1).

Les résultats encourageants présentés à la première Conférence FRIEND de Bolkesjö, Norvège, 1989, associés avec l'adaptabilité des procédures d'organisation et d'implantation du projet, ont conduit à l'établissement d'autres Groupes FRIEND dans les régions méditerranéennes (FRIEND AMHY), en Afrique, dans le Sud-Est asiatique, et dans la région du Nil. Ces Groupes FRIEND sont programmés par phases de 4 ans, terminées par une Conférence où les principaux résultats sont présentés, discutés et éventuellement plus largement diffusés.

Depuis 1985, une grande part de progrès a ainsi été assurée dans la compréhension des variabilités temporelles et spatiales des régimes hydrologiques. Le projet FRIEND a aussi développé un important volet de formation, qui contribue à améliorer les compétences des hydrologues, et à renforcer les capacités des services hydrologiques nationaux à mieux évaluer leurs ressources en eaux.

FRIEND représente aujourd'hui un réseau d'expertise couvrant l'Europe occidentale et orientale, la région méditerranéenne, l'Afrique, l'Asie, le Pacifique, et bientôt l'Amérique Latine.

Ce Rapport est en étroite liaison avec la troisième Conférence FRIEND qui se tiendra à Postojna, Slovénie, du 1 au 4 octobre 1997. Il comprend les principaux résultats de recherche obtenus sur la période 1993-97 par les Groupes FRIEND NEF (Europe du Nord) et AMHY (zone méditerranéenne), ainsi que des contributions des Groupes d'Afrique occidentale, centrale et australe.

Je voudrais exprimer mes remerciements à tous les hydrologues qui ont contribué au succès du projet FRIEND, et en particulier à Guy Oberlin, Coordinateur du Groupe AMHY, qui a édité ce Rapport, au nom et sur mandat du Comité du Rapport FRIEND.

Acknowledgments

The present report was prepared under the responsibility of the FRIEND Report Committee (FRC), chaired by Guy Oberlin. It must be noticed that, after the author's tasks (the basic contributions) and before the Report Editor's ones (report finalizing and editing), a very important role was played by the Chapter Editors.

Each of the Chapter Editors was in charge of the first drawing up of one chapter (first improvement of the edition with the authors, writing of a short introduction and a short conclusion, contacts with the Report Editor...). So, the FRC thanks particularly the following people for their work :

H. Zebidi (Introduction)

G. Rees (Chapter 1 - International FRIEND Group Databases)

N. Arnell (Chapter 2 - Regimes and Regional Hydrology)

A. Bullock (Chapter 3 - Low Flows and Droughts)

P. Versace, E. Ferrari (Chapter 4 - Floods)

C. Llasat (Chapter 5 - Heavy rains)

P. Seuna, A. Lepistö (Chapter 6 - Physical processes of runoff formation)

A. Afouda (Chapter 7 - Long series : models and trends)

A. Gustard, P. Givone, G. Oberlin (Chapter 8 - Integrated water management, & futures for FRIEND)

P. Hubert (Conclusions)

The authors having prepared one or several contributions are listed at the end of the report, with their coordinates. The Chapter Editors are obviously present in the list.

J. Rodda and D. Ellis have improved the english of several contributions.

E. Desbos and G. Oberlin have ensured the re-reading of the chapter introductions and conclusions, the translation in french, and the basic edition of the Report itself. J. Baudel has finalized the edition for the printer.

In addition, the FRIEND Report Committee would like to thank the following organisations for contributing financial resources and project facilities : Cemagref, GIP HydrOsystemes, GIS AMHY, UNESCO, European Commission.

ooooo

Remerciements

Ce Rapport a été préparé sous le pilotage du Comité du Rapport FRIEND (CRF/FRC), présidé par Guy Oberlin. Il faut préciser qu'entre les tâches initiales des auteurs des contributions, et les tâches finales des éditeurs du Rapport, un rôle intermédiaire important a été joué par des Editeurs de Chapitres. Chacun d'eux était en charge de la première mise au point du Chapitre : édition homogénéisée des contributions en contact avec les auteurs, brèves introduction et conclusion du Chapitre, contacts avec l'éditeur du Rapport, etc... Le Comité du Rapport FRIEND remercie donc tout particulièrement, pour cette tâche :

H. Zébid,	pour le chapitre : Introduction
G. Rees,	pour le chapitre 1 : Bases de données internationales FRIEND
N. Arnell,	pour le chapitre 2 : Régimes et hydrologie régionale
A. Bullock,	pour le chapitre 3 : Etiages et sècheresses
P. Versace, E. Ferrari,	pour le chapitre 4 : Crues
C. Llasat,	pour le chapitre 5 : Fortes pluies
P. Seuna, A. Lepistö,	pour le chapitre 6 : Processus physiques de la formation des écoulements
A. Afouda,	pour le chapitre 7 : Longues séries, modèles et tendances
A. Gustard, G. Oberlin, P. Givone,	pour le chapitre 8 : Gestion intégrée des eaux, et quelques futurs de FRIEND
P. Hubert,	pour le chapitre : Conclusions

Les auteurs de ce Rapport, qui y ont présenté une ou plusieurs contributions, sont cités à la fin du volume, avec leurs coordonnées. Les Editeurs de Chapitre y sont évidemment présents.

J. Rodda et D. Ellis ont amélioré l'anglais de certaines des contributions.

E. Desbos et G. Oberlin ont relu et homogénéisé les différentes introductions et conclusions de chapitres, assuré les traductions en français, et réalisé l'édition proprement dite du Rapport. J. Baudel a finalisé cette édition pour l'imprimeur.

Enfin, le Comité du Rapport FRIEND voudrait remercier les organisations suivantes qui ont contribué au financement du Rapport ou soutenu les conditions matérielles de son édition : Cemagref, GIP HydrOsystemes, GIS AMHY, UNESCO et Commission Européenne.

Contents

Preface	iii
Acknowledgments	v

Introduction

• FRIEND presentation	13
• Northern European FRIEND (NEF). The first Group : inception and progress	16
• AMHY : a European Group for regional Hydrology in the Alpine and Mediterranean area	22
• Highlights on Southern Africa FRIEND Group (SADC)	24
• AOC FRIEND Group	26
• The Nile Basin FRIEND project	27
<i>References</i>	29

Chapter 1 - International FRIEND Group Data Bases

Short introduction	31
• The FRIEND European Water Archive	33
• Adequate Database Management Tools	38
• Data selected for the AMHY database	43
• The Southern African FRIEND database	45
• BADOIE, the FRIEND AOC database management tool	50
• FRIEND AOC database inventory	54
• GIS aspects of a FRIEND database	56
Short conclusion	59
<i>References</i>	62

Chapter 2 - Regimes and regional hydrology

Short introduction	63
• European hydroclimatology : the continental scale	67
• European regimes : diversity and features	71
• Stability of river flow regimes	79
• Tropical regimes and climatic trends	87
• Hydrological regionalization in Western and Central Africa and in Mali	93
• Tropical regimes and climatic trends in the Congo-Zaire catchment	96
• Regime synthesis, modelization and display : QdF approaches and regionalization	99
• Scale effects in runoff mapping	109
• Regional quantification of catchment sensitivity to climate variability	119
Short conclusion	124
<i>References</i>	125

Chapter 3 - Low flows and droughts

Short introduction	129
• Low flows and droughts in Northern Europe	132
• Regional water resources and drought assessment in Southern Africa	149
• Long term effects of rain shortage : the ill rivers of Western and Central Africa	158
• Drought in South-Eastern Europe	163
• Statistical analysis of low flows with zero discharges	167
Short conclusion	171
<i>References</i>	175

Chapter 4 - Floods

Short introduction	179
• Developments with AGREGEE, a statistical model using hydrometeorological information	181
• Validation of synthetic tools by simulation	192
• Comparative study of flood characteristics in Southern Africa	198
• Regional hierarchical approach to flood frequency analysis	202
• The SMFH/NIMH Synthetic Hydrographs Computing Methods	210
• Renewal processes for flood analysis	223
• Large floods in Europe	229
• A new Modified Rational Method	237
Short conclusion	245
<i>References</i>	247

Chapter 5 - Heavy Rains

Short introduction	253
• Rain intensities in the french Alps	255
• Rain cluster paths in coastal chains	263
• Meteorological conditions of heavy rains	269
• Mapping of statistical characterization of heavy rains at national scale	277
• Application of weather radar in mountaineous basins	284
• Stochastic point models of rainfalls and their extremes	291
Short conclusion	298
<i>References</i>	301

Chapter 6 - Physical processes of runoff formation

Short introduction	305
• Global review of isotope hydrological investigations	307
• Hydrological processes in forested catchments	317
• Process studies in agricultural catchments	330
• Rainfall-runoff modeling and regionalization : the ERREAU programme in Ivory Coast	338
Short conclusion	341
<i>References</i>	344

Chapter 7 - Long series : models and trends

Short introduction	349
• Fractal characteristics of rainfall time series	352
• Long rainfall series in non Sahelian Western and Central Africa	357
• Long series available in AMHY database	362
Short conclusion	367
<i>References</i>	369

Chapter 8 - Regional hydrology, integrated water management, and some futures for FRIEND

Short introduction	371
• The concept of dynamic slowing down, in water integrated management	373
• An hydrological definition of flood vulnerability	381
• Regional hydrological determinants for instream ecology	386
• Future directions for Northern European FRIEND	391
• The future of Southern Africa FRIEND project	393
• Regional hydrology and sustainable development in Western and Central Africa	395
• Prevention and management of environmental hazards in the Hindu-Kush-Himalayas	397
Short conclusion	401
<i>References</i>	405

Conclusions

• Progress in regional hydrology through FRIEND	407
• From analysis to synthesis in Hydrology : some adequate levels of modelization	410
• Regionalization and subsidiarity : an example of hierarchical approach in flood control	417
• The Challenge for FRIEND	419
• The international co-operation induced by FRIEND	423
Short final conclusion	426
<i>References</i>	428

List of chapter editors and authors	429
--	-----

ooooo

The chapter introductions and conclusions, the titles, and the figure and table legends, are written both in english and in french.

ooooo

Sommaire

Préface	iii
Remerciements	v

Introduction

• Présentation du projet FRIEND	13
• FRIEND Europe du Nord. Le premier Groupe FRIEND : origine et évolution	16
• AMHY : un groupe européen d'HYdrologie régionale pour la zone Alpine et Méditerranéenne	22
• Aperçu sur le Groupe FRIEND Afrique Australe	24
• Le Groupe FRIEND AOC	26
• Le projet FRIEND Bassin du Nil	27
<i>Références bibliographiques</i>	29

Chapitre 1 - Bases de données internationales des Groupes FRIEND

Brève introduction	31
• La base de données hydrologique européenne EWA du projet FRIEND	33
• Outils de modélisation adéquats des systèmes d'information	38
• Données sélectionnées de la base AMHY	43
• La base de données FRIEND Afrique Australe	45
• Badoie: outil de gestion de la base de données du projet FRIEND AOC.	50
• Etat de la base de données du projet FRIEND AOC	54
• SIG et bases de données FRIEND	56
Brève conclusion	59
<i>Références bibliographiques</i>	62

Chapitre 2 - Régimes et hydrologie régionale

Brève introduction	63
• Hydroclimatologie en Europe : l'échelle continentale	67
• Régimes européens : diversités et caractéristiques	71
• Stabilité des régimes d'écoulements en rivières	79
• Régimes tropicaux et tendances climatiques	87
• Régionalisation hydrologique en Afrique de l'Ouest et Centrale et au Mali	93
• Régimes tropicaux et tendances climatiques dans le bassin du Congo-Zaïre	96
• Synthèses régionales des régimes hydrologiques : approche QdF et régionalisation	99
• Effets d'échelle et cartographie des écoulements	109
• La sensibilité des bassins à la variation du climat : quantification régionale	119
Brève conclusion	124
<i>Références bibliographiques</i>	125

Chapitre 3 - Etiages et sècheresses

Brève introduction	129
• Etiages et sècheresses en Europe du Nord	132
• Estimation des ressources en eau et des sècheresses, en Afrique Australe	149
• Effets durables du déficit des précipitations : les rivières malades d'Afrique de l'Ouest et du Centre	158
• La sècheresse dans la partie Sud Est de l'Europe	163
• Analyse statistique des étiages avec débits nuls	167
Brève conclusion	171
<i>Références bibliographiques</i>	175

Chapitre 4 - Crues

Brève introduction	179
• Développements sur AGREGEE, un modèle statistique utilisant l'information hydrométéorologique	181
• Validation de modèles de synthèse par simulation	192
• Etude comparative des caractéristiques des crues en Afrique Australe	198
• Etude de la distribution des crues par une approche hiérarchique régionale	202
• Les méthodes SMFH/NIMH de calcul des hydrogrammes synthétiques monofréquence	210
• Analyse des crues par la théorie du renouvellement	223
• Les grandes crues en Europe	229
• La nouvelle méthode rationnelle modifiée	237
Brève conclusion	245
<i>Références bibliographiques</i>	247

Chapitre 5 - Fortes pluies

Brève introduction	253
• Intensités pluvieuses dans les Alpes françaises	255
• Trajectoires des noyaux pluvieux dans des chaînes montagneuses côtières	263
• Conditions météorologiques des pluies fortes	269
• Cartes de caractérisation statistique des pluies fortes à l'échelle nationale	277
• Application des radars météorologiques aux bassins versants montagneux	284
• Modèles stochastiques ponctuels des pluies et de leurs extrêmes	291
Brève conclusion	298
<i>Références bibliographiques</i>	301

Chapitre 6 - Processus physiques de formation des écoulements

Brève introduction	305
• Revue globale des recherches hydrologiques à l'aide d'isotopes	307
• Processus hydrologiques des bassins forestiers	317
• Etudes des processus dans certains bassins versants agricoles	330
• Modélisation pluie-débit et régionalisation : le programme ERREAU en Côte d'Ivoire	338
Brève conclusion	341
<i>Références bibliographiques</i>	344

Chapitre 7 - Longues séries : modèles et tendances

Brève introduction	349
• Caractéristiques fractales des séries pluviométriques	352
• Longues séries pluviométriques en Afrique de l'Ouest et Centrale non sahélienne	357
• Longues séries disponibles dans la base AMHY	362
Brève conclusion	367
<i>Références bibliographiques</i>	369

Chapitre 8 - Hydrologie régionale, gestion intégrée des eaux, et quelques pistes d'avenir pour FRIEND

Brève introduction	371
• Le concept de ralentissement dynamique, en gestion intégrée des eaux	373
• Une définition hydrologique de la vulnérabilité aux inondations	381
• Déterminants hydrologiques régionaux de l'écologie des rivières	386
• Orientations futures pour le projet FRIEND Europe du Nord	391
• L'avenir du projet FRIEND Afrique Australe	393
• Hydrologie régionale et développement durable en Afrique de l'Ouest et Centrale	395
• Prévention et gestion des risques environnementaux dans le Groupe Hindu-Kush-Himalayas	397
Brève conclusion	401
<i>Références bibliographiques</i>	405

Conclusions

• Progrès réalisés en hydrologie régionale grâce à FRIEND	407
• De l'analyse à la synthèse en Hydrologie : des niveaux pertinents de modélisation	410
• Régionalisation et subsidiarité : un exemple d'approche hiérarchisée de la gestion des crues	417
• Le défi de FRIEND	419
• La coopération internationale induite par FRIEND	423
Brève conclusion	426
<i>Références bibliographiques</i>	428

Liste des éditeurs de chapitre et auteurs	429
--	------------

oooo

Les introductions et conclusions de chapitre, les titres, et les légendes des figures et tableaux, sont édités en anglais et en français.

oooo

Introduction

FRIEND presentation

Présentation du projet FRIEND

H. Zebidi

The FRIEND project (Flow Regimes from International Experimental and Network Data) is a project within the International Hydrological Programme. Its aim is to improve knowledge of flow regimes under different hydrological conditions. The FRIEND project started in 1985 under the third phase of the IHP (1984-1989) ; it was then continued in IHP's fourth phase (1990-1995), and, following the request of UNESCO's Member States, is being continued in the fifth phase of the IHP (1996-2001) as project 1.1

1 Objective

The aim of the FRIEND project is to develop knowledge of flow regimes on a regional scale through the analysis of data from experimental basins and hydrological networks. The idea of the FRIEND project arose from the fact that, despite the development of experimental and representative basins, surface water data is found to be unevenly distributed across the regions, which makes it difficult to develop simulation on flow regimes. The idea is to put together, in the regions, data collected from the surrounding countries and for the related countries to work together to improve knowledge about river flow regimes.

2 Expected results

The FRIEND project is expected to help improve knowledge on hydrological parameters for the design of hydraulic structures. It will also contribute to the extrapolation of the results obtained to ungauged basins situated in the same hydrological conditions. The overall benefit of the FRIEND project is the availability of reliable information for the rational management of surface water resources at watershed level and national level.

In addition to the development of research activities, it was found necessary, in some regions, to include a training component for :

- the introduction of new methodologies for hydrological research
- the upgrading of softwares used for hydrological data analysis
- the strengthening of the capacity of hydrological services to assess and manage their national surface water resources.

3 Organization

Each FRIEND Group is organized around a **Coordination Centre** established in one of the countries of the region. The Coordination Centre is in permanent co-operation with the **focal points** of the

project in each related country and receives scientific, technical and funding support from several international, regional and national institutions. There are in fact several players in a FRIEND project which may be summarized as follows :

Coordination Centre

- Provides a Project Coordinator
- Ensures the Secretariat of the project
- Hosts the Regional Database
- Receives, processes and stores data from the countries for use in research activities

Countries in the region

- Nominate a focal point for the project
- Nominate national experts to take part in research activities
- Contribute selected data to the regional Database

Co-operating Institutions

- Provide scientific and technical contributions
- Contribute towards funding the activities
- Take part in selected activities

4 Implementation of the FRIEND project

To take part in a FRIEND project, each country is expected to contribute selected data to the Regional Database : this is the rule of the game. The countries then meet together to select a research programme of interest to their scientific and technical needs, composed in general of a limited number of topics. For each research topic, a research group is established and a leader nominated to co-ordinate the related activities. The implementation of the activities of each FRIEND Group is directed by a **Steering Committee** chaired by the Coordinator and composed of the leaders of the research topics, as well as the representatives of UNESCO and other institutions involved. The Steering Committee meets at least once a year. Short scientific seminars to discuss the first results obtained are sometimes organized in conjunction with the Steering Committee meetings.

A **FRIEND Conference** is convened every four years and at which the main results obtained by the different FRIEND Groups are presented and discussed. The output of these conferences is the publication of :

- the Conference Proceedings
- a Special Report including research activities selected from the different FRIEND Groups.

Two FRIEND Conferences have already been organized :

- First Conference: Bolkesjo (Norway), April 1989
- Second Conference: Braunschweig (Germany), October 1993

The Third FRIEND Conference will be held in Postojna, Slovenia, October 1997.

5 The FRIEND Family

Six FRIEND Groups are already active :

FRIEND Northern Europe. Includes twenty-two countries. Its Coordination Centre is the Institute of Hydrology, Wallingford, UK.

FRIEND/Alpine and Mediterranean region (AMHY). Composed of thirteen countries with a Coordination Centre established at CEMAGREF, Lyon, France.

FRIEND/Western and Central Africa. Thirteen countries are involved and the Coordination Centre is in the *Sous Direction de l'Hydrologie, Abidjan, Côte d'Ivoire.*

FRIEND/Southern Africa. Includes eleven countries; the Coordination Centre is the Department of Civil Engineering, University of Dar-es-Salaam, Tanzania.

FRIEND/Nile. Established in March 1996 with six countries and a Coordination Centre established at the University of Dar-es-Salaam.

FRIEND/Hindu Kush Himalayan region/HKH. Set up in March 1996.

The following groups are in the process of being established :

FRIEND/South East Asia

FRIEND/Latin America

6 Conclusion

The FRIEND project is a co-operation research exercise developed at regional level to improve knowledge on flow regimes as a basis for the reliable assessment of surface water resources and their rational management. We expect that the development of several groups in the different regions of the world will lead to the establishment of an international network of expertise in the framework of the International Hydrological Programme.

Northern European FRIEND. The first FRIEND group : inception and progress

FRIEND Europe du Nord. Le premier groupe FRIEND : origine et évolution

A. Gustard

1 Introduction

The FRIEND - Flow Regimes from International Experimental and Network Data - research programme is an international collaborative study into regional hydrology. It was first established by UNESCO in 1985 as part of the International Hydrological Programme to improve cooperation in research in regional hydrology. The primary objective of the FRIEND project has been to improve the understanding of hydrological variability and similarity across time and space in order to develop hydrological science and practical design methods. To achieve this it has been essential to permit hydrological research to cross national boundaries. This has been done in two ways. First, by developing international hydrological data bases of time series and spatial data including catchment boundaries, climate, land use and soil type held in vector or raster form. Second, by establishing project groups that could exchange models and analysis techniques and interpret the results using a common approach to analysing data derived from different hydrological regions.

The FRIEND project was initially established in Northern Europe, but such has been the interest in the project that groups have now been established in the Mediterranean and Alpine region of Europe, in Southern Africa, in West Africa, in the Hindu-Kush Himalayan region, in Asia-Pacific and research programmes are being planned in South America and the Nile region, as shown in Figure 1. The wide geographic extent of involvement in FRIEND research is further demonstrated by Table 1, which lists the countries within each FRIEND group. The Northern European FRIEND group with 22 countries liaises closely with the AMHY (Alpine and Mediterranean) group, which is flourishing with 15 countries actively contributing data. Switzerland and France are represented in both groups. Links between all international FRIEND groups are close and are maintained by international FRIEND Coordination Committee meetings.

2 Inception of Northern European FRIEND

The Northern European FRIEND project was initiated in 1985 by the IHP Committees of the UK, Germany, The Netherlands and Norway who seconded full time scientists for a period of three years to collaborate in an international project group based at the Institute of Hydrology in Wallingford. They were soon joined by hydrologists seconded for shorter periods from a number of European countries and the project was supported by the provision of hydrological data from all European countries in the project area. The first phase of the project was completed in 1989, when the data base contained river flow data from 1350 gauging stations from 13 countries. The second (completed in 1993) and third phases of the project have extended the geographical area to eastern Europe and increased the data base to include data from over 4000 catchments in 25 countries.

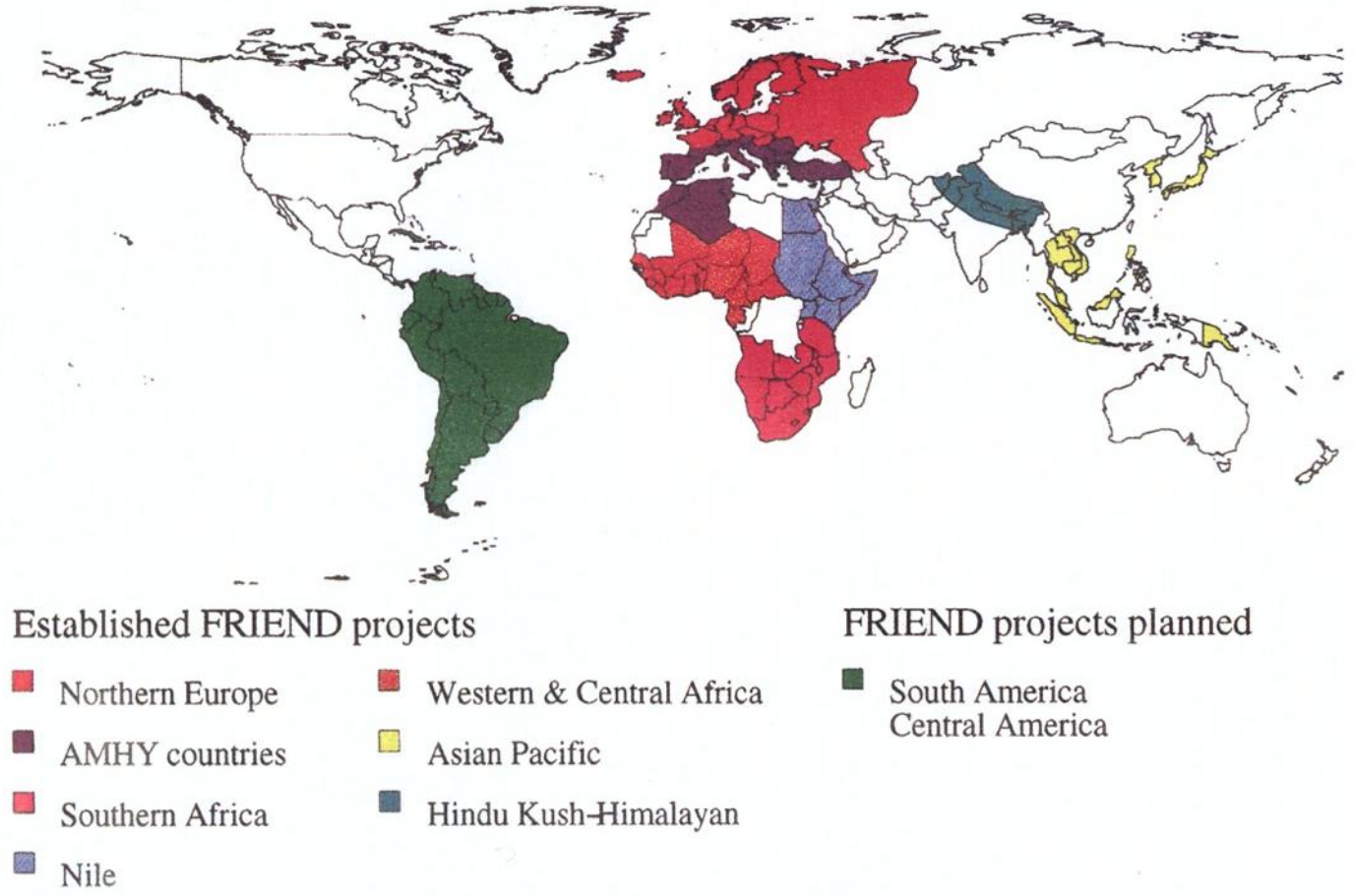

Figure 1 : Global Perspective on FRIEND participation
Figure 1 : Perspective globale sur la participation à FRIEND

Table 1 : Countries within FRIEND Groups**Table 1 : Pays participant aux Groupes FRIEND**

Northern Europe	Austria Belarus Belgium Czech Republic Denmark Estonia	Finland France Germany Hungary Iceland Ireland	Luxembourg Netherlands Norway Poland Russia	Slovak Rep. Sweden Switzerland Ukraine UK
AMHY	Albania Algeria Austria Bulgaria	France Greece Italy Morocco	Portugal Romania Spain Switzerland	Tunisia Turkey Former Yugoslavia
Hindu Kush-Himalayan	Afghanistan Bangladesh	China India	Myanmar Nepal	Pakistan
West & Central Africa	Benin Cameroun	Côte d'Ivoire Ghana	Guinea Mali	Nigeria
Southern Africa	Angola Botswana Lesotho	Malawi Mozambique Namibia	Rep. S. Africa Swaziland Tanzania	Zambia Zimbabwe
South East Asia	Australia China Indonesia	Japan DPR Korea Rep. Korea	Malaysia New Zealand Papua New Guinea	Philippines Thailand Vietnam

The results of the Northern European FRIEND project have been presented in the proceedings of two conferences. The first was held in Norway in 1989 and was published in IAHS Publication No. 187 (Roald *et al.*, 1989), the second was held in Germany in 1993 and published in IAHS Publication No. 221 (Seuna *et al.*, 1994), and in a report series (Gustard *et al.*, 1989; Gustard, 1993). The results of the third phase will be presented at an international conference in Postojna, Slovenia in October 1997.

3 Development of FRIEND research

The FRIEND research programme is essentially a coordinated collection of individual research projects, undertaken by international groups with staff drawn from three or more countries. There are five individual project groups in the Northern European FRIEND, each with approximately 10 participants, as follows :

- Database
- Low flows
- Large scale variations
- Techniques for extreme rainfall and runoff estimation
- Processes of streamflow generation in small basins

These projects are overseen by the FRIEND Steering Committee which meets annually and is made up of country representatives, nominated by national IHP committees, and representatives from UNESCO, WMO, GRID (the Global Resource Information Database of the United Nations Environment Programme (UNEP)) and the European Environment Agency. The project secretariat is based at the Institute of Hydrology and coordinates the activities of the project groups and provides administrative support to the steering committee. The main research activities of each group are summarised in general terms below :

The European Water Archive

A key achievement of the FRIEND project has been the development of an international hydrological database by collecting flow data from over 4000 small research basins and national network stations from northern Europe. In addition, an inventory of catchment characteristics has been compiled using digital cartographic techniques by overlaying basin boundaries on vector and gridded thematic data bases. The European Water Archive has been a major focus of the project, initially in data archiving and subsequently in data analysis. Station details, flow statistics and time series data are now held on an ORACLE data base management system whilst vector and gridded thematic data are held on an ARC INFO Geographical Information System.

Catchment and regional modelling of low flows

The low flow investigations have ranged from physically based and conceptual modelling studies to multi-variate low flow studies at the regional and European scale. Modelling studies have identified the importance of catchment hydrogeology in controlling the detailed variation in low flows. Distributed and simple conceptual models have been used to assess the sensitivity of drought frequency to the definition of droughts. Analyses have included the frequency of drought duration and deficit volumes. These studies have enabled the factors which influence drought frequency and the impact of groundwater abstraction on drought severity to be determined.

Large scale variations in river flow characteristics in Europe

The overall objective of this project is to define and map spatial and temporal patterns in river flow regimes in northern Europe. Work has focussed on the definition of representative flow regimes, the presentation of runoff data on a grid, and the examination of temporal patterns in flow regimes and seasonal runoff volumes.

Techniques for extreme rainfall and runoff estimation

The primary objectives of this project are to review, develop, and test different techniques for extreme rainfall and runoff estimation. These have included flood frequency, rainfall/runoff analysis methods and a combination of the two. The French methods which use a combination of rainfall and runoff flood frequency analysis, such as the AGREGE development of the traditional GRADEX method are being tested in different applications with promising results. A new frequency version of TOPMODEL using a continuous simulation modelling approach to flood frequency estimation has been developed. Furthermore, national approaches to flood estimation in some European countries have been reviewed.

Physical processes of streamflow generation in small basins

The project is developing closer links between field workers and physical hydrologists and mathematical modellers. It is very important that contact be encouraged between those whose work is "data-driven" and those whose approach is rather more conceptual. The development of models (and the correct interpretation of their results) requires a proper understanding of the physical processes operating in the system of interest. A key theme of this project is improving our understanding of runoff formation using a combination of experimental and modelling techniques. These include environmental tracer techniques combined with hydraulic assessment of groundwater conditions and the application of physically based distributed catchment models.

4 Cooperation with central and eastern Europe

The first phase of the FRIEND project demonstrated the feasibility of coordinating activities from different European research groups and operational agencies. In 1989 by the end of the first phase, 13 countries in northern Europe were contributing data to the project, with observers from Poland, Czechoslovakia and Russia. All participants were funded nationally by university grants, and government ministries with UNESCO providing funds for steering committee meetings.

In 1992, during the second phase of FRIEND and in response to a formal request from the Czech National Committee for Hydrology and the Polish International Hydrological Programme Committee the membership of FRIEND was officially extended to include Poland, the Czech and Slovak Republics and Russia. It was also agreed that the project would respond positively to requests for membership from other countries in eastern and central Europe. However, lack of funds in these countries meant that without external funding this membership would remain little more than an expression of interest. This was achieved in 1992 when the FRIEND project made a successful bid to the CEC call for scientific proposals "with the objective of exploring the perspectives of scientific and technological cooperation between the Countries of Central and Eastern Europe and the European Community" (Gustard *et al.*, 1997).

Table 2 provides a summary of FRIEND meetings held between 1993 and 1996. There have been a total of 26 meetings and workshops when project groups have met to exchange ideas, discuss results and plan collaborative work.

5 Development of links with other international programmes

At the outset of the FRIEND project it was considered important to maintain close links with related international research programmes. For example, this included the World Meteorological Organisation, the European Union's CORINE programme which produced digital spatial data and includes flow archives for Europe and the European Research Basin network. More recently the newly established European Environmental Agency has been assisted by the network of FRIEND organisations with experience of cooperation in the area of surface water. The Global Runoff Data Centre at Koblenz in Germany has also cooperated with FRIEND database development. The United Nations Environment Programme, through their GRID (Global Resource Information Database) project, has also expressed an interest in following developments in FRIEND data and analysis techniques. The International Association of Hydrological Sciences has been one of the main organisations supporting two FRIEND conferences. There are clear benefits to both the FRIEND project and national and international operational and research projects of developing closer links.

Table 2 : Summary of meetings - Northern European FRIEND (phase 3)**Table 2 : Aperçu des réunions - FRIEND Europe du Nord (phase 3)**

Group	Location of meeting	Date
Steering Committee		
No.1	Braunschweig	10 October 1993
No.2	Stará Lesna	11-12 September 1994
No.3	Paris	11-12 September 1995
No.4	Paris	17-18 October 1996
Project Group 1 (Database)		
No.1	Oslo	28-29 November 1993
No.2	CEMAGREF, Lyon	14-15 November 1994
No.3	INTAS, St Petersburg	15-16 July 1996
Project Group 2 (Low Flows)		
No.1	Braunschweig	16 October 1993
No.2	Dutch-Czech workshop	6-10 December 1993
No.3	Wageningen workshop	11-15 April 1994
No.4	Prague workshop	7-11 December 1994
No.5	Vozokany, Slovakia workshop	20-25 June 1995
No.6	Wroclaw, Poland workshop	16-20 January 1996
No.7	Istanbul workshop	29 Oct - 3 Nov 1996
Project Group 3 (Large scale variations in hydrological characteristics in Europe)		
No. 1	Braunschweig	October 1993
No. 2	Southampton	16-17 October 1995
Project Group 4 (Techniques for extreme rainfall and flood runoff estimation)		
No.1	Prague	19-20 May 1994
No.2	Lancaster	16-17 December 1994
No.3	Lancaster	23 September 1995
No.4	Czech Republic	14-15 September 1996
Project Group 5 (Physical processes of runoff generation on a small catchment scale)		
No.1	Prague	8-10 April 1994
No.2	Stará Lesna	12 September 1994
No.3	Dresden	19-20 May 1995
No.4	Wageningen	29 Feb - 2 Mar 1996
No.5	Prague	8-9 November 1996
Conferences		
No.1	Braunschweig	11-15 October 1993
No.2	<i>Postojna</i>	<i>30 Sept - 3 Oct 1997</i>

Meetings planned in italic

AMHY : un groupe européen d'HYdrologie régionale pour la zone Alpine et Méditerranéenne

AMHY : A European group for regional HYdrology in the Alpine and Mediterranean area

G. Oberlin, M. Lang

Le Groupe AMHY s'est constitué en 1991, après que plusieurs des pays participants au Groupe initial FRIEND/NEW (à présent NEF : North European Friend) aient jugé intéressant et faisable de développer le projet FRIEND vers le Sud de l'Europe, et en y invitant les pays africains de la cote sud de la Méditerranée. Cette zone se caractérisant par des régimes hydrologiques de type alpins et méditerranéens, le groupe a décliné cette spécificité dans son sigle AMHY. A la fois par suite des collaborations déjà initiées sous FRIEND avec le Groupe NEF, mais aussi par souci de structurer les collaborations à venir entre Groupes FRIEND voisins, la zone Alpine et Méditerranéenne concernée a été délimitée en recouvrant volontairement le sud de la zone du Groupe NEF, essentiellement via des pays alpins (France, Suisse, etc...) qui collaborent donc à la fois aux Groupes NEF et AMHY. L'extension à l'Est de la zone AMHY est pour l'instant limitée à l'Europe (Turquie). Les pays de la zone la plus ORientale de la MEDiterranée (sigle MEDOR dans les documents AMHY) choisiront, soit de développer un Groupe autonome à qui il sera également proposé de structurer la collaboration avec AMHY via des recouvrements, soit de se joindre au Groupe AMHY. On notera que l'Egypte collabore déjà au Groupe NIL.

Dans son programme initial, le Groupe AMHY a délimité des thèmes et sous-thèmes pour lesquels il paraissait tout à la fois intéressant et faisable de travailler selon les approches de l'hydrologie régionale. Les moyens étant limités, ce programme-cadre a fait l'objet d'un affichage annuel différencié, où quatre classes de niveau d'activité sont représentées via les caractères choisis : les thèmes et sous-thèmes les plus actifs sont en caractère gras et souligné, alors que les inactifs mais souhaités sont en caractère simple (fig. 1). On a ainsi une vision synthétique à la fois de ce que fait le Groupe, et de ce qu'il ne fait pas mais souhaiterait pouvoir faire...

Pour l'essentiel, les travaux sont menés sur les crédits propres (nationaux, le plus souvent) des laboratoires participants. Seuls de rares et modestes crédits internationaux (UNESCO, UE/CE, ...) soutiennent des actions AMHY et FRIEND spécifiques, comme les réunions, séminaires et rapports internationaux. Il en résulte un fonctionnement qui est davantage de type "Réseau" que "Projet" sensu stricto, et les produits des travaux AMHY sont donc davantage méthodologiques que ciblés sur des réalisations internationales. Par exemple, peu de synthèses régionales (cartes, monographies, etc...) ont été préparées dans AMHY, mais plusieurs actions de comparaisons (de concepts, de variables, de modèles, etc...) ont abouti au choix de méthodes de référence communes aux participants. Ceci autorise des évaluations comparatives de résultats nationaux, ce qui est une démarche préalable tout à fait recommandable, tant des points de vue de la qualité des évaluations, que pour préparer de réelles synthèses internationales. Ces dernières, pour se développer, exigeraient des crédits spécifiques affectés aux actions de production du Groupe AMHY, et non pas limités comme aujourd'hui aux seules actions de coordination.

Le Groupe est géré par un Comité de Pilotage (CP) qui comprend un seul Membre (MCP) par pays participant, un représentant des Groupes FRIEND voisins, et quelques représentants d'Institutions concernées (UNESCO, OMM, AISH, etc...). Les thèmes sont coordonnés par un Coordinateur International (CI) du thème, assisté de l'ensemble des Correspondants Nationaux (CNs) des pays participant au thème (un seul CN par pays et par thème). Un rapport est édité chaque année (AMHY).

FRIEND - AMHY PROGRAMME 1996-1997 - TOPICS AND SUB-TOPICS

Theme I : Regional Data Bases

- BRECHE project
- Basic chronics (AMHY-Base)
- Specialized data sets (AMHY SPACE)
- Data processing tools

Thème II : Low Flows regionalization**Theme III : Regimes regionalization**

- Synthetic Models QdF (Discharges-durations-Frequencies)
- Mapping of spatial concepts (RESEDA ; GEWEX and al.)
- Comparison of national regionalization methods
- QdF trends in case of very active water table/river discharge transfers

Theme IV : Rare and Extreme Floods regionalization

- Around the AGREGEE framework
- Historical data exploitation
- Around basic Q(P) models : asymptotic behaviour and long series simulations
- Comparison of methods (AGREGEE, VAPI, PMP/PMF, NRM, etc...) and tools
- Spatial structure in historical large floods of regional extension
- Regional methods for design floods for dams
- Mapping of floods risks

Theme VI : Rare and Extreme Rains regionalization

- Rain and Relief : synthetic micro-climatic aspects for detailed mapping
- Radar support in rain regionalization and hydroclimatic mapping
- Comparison of spatial structures modelling
- Euro-mediterranean mapping of PMP
- Historical highest rains in AMHY area

Theme VII : Erosion and Solid Transport : Regionalized approaches

- Valorisation of scarce data available in solid transport
- Quantification of solid transport and reservoir silting
- Evolution of hydrological regimes induced by reservoir silting
- Erosion control and hydrological consequences

(Theme VIII : Regional Hydrological conditions in Desertification)

Theme IX : Long regional series in discharges and rains

(Theme X : Runoffs and transfers to Mediterranean Sea at regional scale)

Theme XI : Ecohydrology

- New complementary regime variability parameters relevant for ecosystems vulnerability
- Regimes typology adequate for ecosystems habitat (regional modelization)

Theme XII : Regional hydrology adapted to integrated water management

- INONDABILITE approach
- Regional results in Resources and needs (regionalized water balances)

Legend : Bold underlined : active/important, **Bold** : active, Underlined : arising, Ordinary : wished, (In parenthesis) : for information

Figure 1 : *Le Programme AMHY en 1996-97 : des thèmes actifs aux thèmes en attente.*

Figure 1 : *The AMHY Programme in 1996-97 : from the working topics to the potential ones.*

Highlights on Southern Africa FRIEND Group

Aperçu sur le Groupe FRIEND Afrique Australe

S. Mkhandi

The Southern Africa FRIEND project is an international collaborative research study into regional hydrology. It is a contribution to the International Hydrological Programme of UNESCO. The primary object of the Southern FRIEND project has been to improve the understanding of hydrological variability and similarity across time and space in order to develop hydrological science and practical design methods. It is a well known fact that the assessment and management of water resources is complicated by the fact that flow regimes are characterized by spatial and temporal variations. In order to understand the spatial and temporal variability of river flow regimes in Southern Africa, the need to permit hydrological research to cross national boundaries was realised.

The initiation of the Southern Africa FRIEND project started way back in 1990. However the project was officially launched on February 18, 1994 during the first steering committee meeting held at the University of Dar es Salaam, Tanzania. The countries participating in the Southern Africa FRIEND project include ; Angola, Botswana, Lesotho, Malawi, Mozambique, Namibia, South Africa, Swaziland, Tanzania, Zambia and Zimbabwe. The Coordinating Centre for the project is the University of Dar es Salaam, Tanzania. The Coordinating Centre is responsible for project administration and correspondence, development and maintenance of the data base, liaison between research projects and coordination with international agencies, i.e, UNESCO, WMO, IAHS, etc.

The objectives of the Southern Africa FRIEND project are :

- . to create a common hydrological data base for the region by combining existing data sets from individual countries.
- . to develop flood design procedures which will enable estimation of flood frequency relationships throughout the region.
- . to develop low flow design procedures which will enable estimation of the range of low flow and water resource statistics throughout the region.
- . to develop rainfall-runoff models to provide a basis for more detailed design studies and to address problems of the impact of land use change.
- . to train staff in the development and application of flood and low flow design techniques and application of rainfall-runoff modelling to assess water resources.

The organization of the project from the administrative point of view, comprises four levels ; first the UNESCO IHP ; second the Project Steering Committee ; third the Project Coordination Centre and fourth Technical project groups.

Financial support for the activities of the coordination center is provided by the Irish Government through the University of Dar es Salaam. The Overseas Development Administration (ODA) of the U.K. provide support for the participation of the Institute of Hydrology, Wallingford in the project. The Water Research Commission of the Republic of South Africa is funding the participation of the University of Rhodes in the project. A limited financial support is also provided by the Division of Water Sciences of UNESCO.

The execution of the research activities was organized under the following research sub-projects.

Research Sub-projects	Coordinating Institution/s
1. Time series database	University of D'Salaam, Tanzania
2. Spatial database	Institute of hydrology, Wallingford, U.K.
3. Low flow freq. analysis	University of D'Salaam/ Institute of Hydrology
4. High flow freq. analysis	University of D'Salaam
5. Rainfall-runoff modelling	Institute of Water Resources Research, Rhodes University, S. Africa

Training of staff from participating countries on the application of flood and low flow design techniques and rainfall-runoff modelling to assess water resources and impact of land-use change was one of the objective of the Project. The training aspect was emphasized as part of the capacity building in the region. Short training courses which were organized by the University of Dar es Salaam are listed below.

Course	Year/Duration	Participants	Funding
Data processing	1993/One month	15	UDSM/IH
Flood frequency analysis	1994/Two weeks	11	UDSM
Rainfall-runoff modelling	1995/Three week	9	UDSM/Rhodes

Benefits realised from the Southern Africa FRIEND project include :

- Improvement in hydrological design for both low flow and high flow problems
- Improvement in the assessment of water resources and impact of land-use change and catchment management.
- The assembled database covering eleven countries will be used to support water resources and environmental projects in participating countries.

Le Groupe FRIEND/AOC

AOC FRIEND Group

M. Sakho

Le groupe FRIEND/AOC a effectivement pris corps en novembre 1994, à Abidjan, à la suite d'une initiative de l'UNESCO, de relancer dans la sous région, les activités de recherche en hydrologie. Lors de la réunion d'Abidjan et plus tard au cours d'une réunion du comité de pilotage qui a eu lieu à Cotonou en décembre 1995, les thèmes de recherches adoptés ont été les suivants:

THEME	RESPONSABLE
Etiage	Daniel Sighomnou (Cameroun)
Modélisation	Abel Afouda (Bénin)
Régionalisation	Grégoire Alé (Benin)
Gestion des eaux	Nigg Urs (EIER ¹)
Variabilité	Eric Servat (ORSTOM ²)
Qualité eau	Albert Goula Bi Tié (Côte-d'Ivoire)

En soutien aux activités de recherche et afin de consacrer le caractère régional au projet, une banque de données hydropluviométriques est en voie de constitution. En effet, la banque de données régionale, logée à la direction de l'eau de Côte-d'Ivoire et administrée par le coordinateur, a reçu les fichiers du Ghana, du Mali, du Sénégal, de la Guinée, du Tchad, de la Côte-d'Ivoire et du Congo.

Le groupe FRIEND a obtenu le support de la coopération française pour réaliser un programme d'activité minimum constitué de réunions de lancement de chaque thème, d'ateliers scientifiques et de séances de formation pour la période 1996/1997.

L'ORSTOM participe à FRIEND/AOC au niveau scientifique et réalise l'application de gestion de la banque de données, appelée BADOIE³.

Le démarrage de FRIEND/AOC a vu la forte implication des gestionnaires de réseaux qui devront petit à petit, grâce aussi aux efforts de l'UNESCO, céder la place à la génération de chercheurs que le projet va révéler.

¹ EIER: Ecole Inter Etat des Ingénieurs de l'Equipement rural (Ouagadougou)

² ORSTOM: Institut Français pour la recherche et le développement en coopération

³ BADOIE: Banque de Données Inter Etats

The Nile Basin FRIEND project

Le projet FRIEND Bassin du Nil

R. Kachroo

The project initiated in March 1996 when UNESCO extended an invitation to the National Committees of the International Hydrological Programme (IHP) and the representatives of TECCONILE of the countries of the Nile Basin to meet at the University of Dar es Salam. The meeting was called with the view to initiate and plan the implementation of the project.

1 Participation

The representatives of Egypt, Sudan, Uganda, Kenya, Tanzania and Zaire attended the meeting. Each of these representatives expressed their country's interest in participation.

2 Exchange of data

Each country confirmed their interest, to create a common database and, in the exchange of data within the agreed protocol and framework of the project.

It may be of interest to mention here that the database of the Nile Basin FRIEND will not be restricted only to the river Nile and its tributaries but also to other rivers in the participating countries. For instance the Nile Basin FRIEND database will contain data for the Rufigi river basin of Tanzania. The amount of data that each country will contribute will remain to be the choice of the country. The project database will be protected and the exchange of data from one participating country to another will be done within the restrictions of an agreed data exchange protocol.

It was agreed that the Water Resources Engineering Programme of the University of Dar es Salaam in co-operation with the TECCONILE secretariat will be responsible for coordinating the creation of the project data base.

3 Research Themes

The following themes will be researched during the implementation of the project.

- (1) Rainfall runoff modelling
- (2) Modelling sediment transport
- (3) Analysis of low flows
- (4) Flood frequency analysis

The Rainfall runoff modelling work will be done jointly at the National Research Centre for Water in Egypt and the University of Dar es Salaam. The work on sediment transport will be done at the Water Resources Directorate in Sudan. The University of Nairobi will take the responsibility of low flow analysis and the analysis of the frequency of flood flows will be done at the National Research Centre for Water in Egypt.

4 Training

All the participating countries at the Dar es Salaam meeting emphasized the role of training and capacity building. Although a plan for training has not been finalized, it seems that the thrust of the project will be on training and capacity building. A number of short courses will be offered under the auspices of the project.

5 Financial and Technical support

It was agreed that UNESCO will contribute to the organization of the regular steering committee meetings which will be held once a year.

The Coordination Centre, ie the Water Resources Engineering Programme of the University of Dar es Salaam, will contribute to the management of the project.

The countries shall contribute towards the cost of research or training activities carried out by them in kind or in provision of funding.

Additional funding and technical assistance is to be sought from partners and from bilateral, regional and international organizations to supplement the costs of implementation of research activities, training and capacity building.

References of the introduction chapter***Références bibliographiques du chapitre d'introduction***

AMHY : Annual Reports, Technical Documents in Hydrology, Water Science Division, UNESCO (n°1 : 1991-92 to n°5 : 1995-96).

Gustard A. (ed) (1993) : Flow Regimes from International Experimental and Network Data. (FRIEND), Vol. I, Hydrological Studies; Vol. II, Hydrological Data; Vol. III, Inventory of streamflow generation studies. Institute of Hydrology, Wallingford, Oxfordshire, UK.

Gustard A., Roald L.A., Demuth S., Lumadjeng H., Gross R. (1989) : Flow Regimes from Experimental and Network Data (FRIEND), Institute of Hydrology, Wallingford, Oxfordshire, UK.

Gustard A. *et al.* (eds) (1997) : Advances in Regional Hydrology through East European Cooperation. Final Report to Commission of European Communities (in press).

Roald L., Nordseth K., Hassel K.A. (eds.) (1989) : FRIENDS in Hydrology, Proc. Int. Conf. at Bolkesjø, Norway, 1-6 April 1989. IAHS Publ. No. 187.

Seuna P., Gustard A., Arnell N.W., Cole G.A. (1994) : FRIEND: Flow Regimes from International Experimental and Network Data, Proc. Int. Conf. at Braunschweig, Germany, 11-15 October 1993, IAHS Publ. No. 221.

Chapter 1

International FRIEND Group Databases

Short introduction

H.G. Rees

The primary aim of the FRIEND project is to develop, through regional analysis, a better understanding of the spatial and temporal variability of hydrological regimes. Little can be achieved, however, without the provision of good quality data. It is no coincidence, therefore, that the establishment of an international hydrological database has been a common feature of every successful FRIEND project to date. In each instance, a considerable amount of time and effort has been invested in designing and building the database and ensuring that the data stored are reliable, consistent and suitable for hydrological analysis.

FRIEND databases generally contain time series of long-term river flow data and, in some cases, time series of precipitation data. Spatial data sets, such as digitised catchment boundaries and digital maps of climatological and physiographical parameters, have also become integral components of FRIEND databases and these are conventionally kept within Geographical Information Systems. The data stored on each respective FRIEND group database is directly influenced by the type of research conducted within the project. For example, in the AMHY project, where the research mainly focuses on flood regionalization and probability, the database contains time series of both discharge and rainfall data at a range of sampling intervals from 60 seconds to a month. In other projects, where low flows and long-term trends in hydrological regime have been the focus of attention, the data may be stored at the daily, 5-day, 10-day or monthly time-steps.

Though FRIEND databases serve the common purpose of facilitating regional analysis, the database management software and hardware, upon which each is based, necessarily complies with the software and hardware strategy of the host organisation. While this may hinder the exchange of data between groups, much can be learnt from the way in which the respective database are designed and maintained. This chapter outlines the design, development and management of four FRIEND group databases. In the first paper, the database of the Northern European FRIEND project, the European Water Archive, is described. Comprising time-series and spatial data for over 5000 catchments in 26 countries (including partial AMHY area), the European Water Archive is one of the most extensive hydrological data sets in existence. In the next paper, Manea describes the implementation, by the AMHY group, of an object oriented database system and shows that it provides a more efficient, and quicker, facility for hydrological data management. Breil, in the following paper, reviews the contents of the specific AMHY database (out of EWA and national bases) which comprises data for 244 river gauging stations and 92 rainfall stations. The fourth paper, by Andrews, summarises the databases of the Southern African FRIEND project. The river flow archive contains daily flow data for almost 700 catchments in 11 southern African countries. A comprehensive spatial database has also been developed within the project and includes region-wide data sets of integrated catchment boundaries, geology, hydrogeology and wetlands. The next two papers, by Boyer *et al.*, provide details of BADOIE, the database of the FRIEND - Western and Central Africa (AOC) project, that has been developed using a PC based database management system. The design and functional aspects of the database are described in the first of Boyer's papers, while the second summarises the contents which include data from 522 gauging stations and 1120 rain gauges in the region. In the final paper, Brilly reflects on the application of GIS in hydrology and the FRIEND project in particular. The chapter then closes with some general concluding remarks.

Brève introduction

H.G. Rees

Le premier objectif du projet FRIEND est de développer, à travers l'analyse régionale, une meilleure compréhension de la variabilité spatiale et temporelle des régimes hydrologiques. Cependant, sans disposer de données de bonne qualité, seule une petite partie de cet objectif peut être réalisée. Ce n'est donc pas une simple coïncidence que l'établissement d'une base de données hydrologiques internationale ait été une caractéristique commune à tous les projets FRIEND réussis à cette date. Dans chacune de ces circonstances, une somme considérable de temps et d'efforts a été investie dans la conception et l'élaboration de la base de données, tout en s'assurant que les données stockées étaient fiables, et pertinentes, pour l'analyse hydrologique.

Les bases de données FRIEND contiennent, d'une manière générale, des séries chronologiques de données des écoulements en rivière sur de longues périodes et, parfois, des séries chronologiques de données de précipitations. Des jeux de données spatiales, telles que les limites numérisées des bassins, et des cartes numériques de paramètres climatologiques et physiographiques, sont aussi devenus une partie intégrante des bases de données FRIEND, et ils sont conventionnellement stockés sous forme de Systèmes d'Information Géographique (SIG). Les données enregistrées dans chacune des bases de données des Groupes FRIEND respectifs sont directement influencées par le type de recherche mené dans chacun des projets. Par exemple, pour le projet AMHY, où les recherches concernent essentiellement la probabilité et la régionalisation en matière de crues, la base de données contient des séries chronologiques à la fois pour des données de débit et de pluie, dans une gamme d'intervalles d'échantillonnage de 60 secondes à 1 mois. Dans d'autres projets, où les étiages et les tendances des longues séries des régimes hydrologiques sont les points essentiels, les données doivent être enregistrées à des pas de temps de l'ordre de la journée, 5 jours, 10 jours, ou 1 mois.

Bien que les bases de données FRIEND servent l'objectif commun de faciliter l'analyse régionale (internationale), les matériels et logiciels de la gestion des données, sur lesquels tout repose, doivent nécessairement respecter la stratégie de gestion des matériels et logiciels de l'organisation qui héberge les données. Outre que cela peut gêner l'échange des données entre les Groupes, il y a beaucoup à apprendre de la manière selon laquelle les bases de données respectives sont conçues et entretenues. Ce chapitre présente l'élaboration, le développement et la gestion des bases de données de quatre Groupes FRIEND. Dans la première contribution, est décrite la base de données du projet NEF, « European Water Archive », EWA. Comprenant des séries temporelles et des données spatiales de plus de 5000 bassins dans 26 pays (zone AMHY partiellement incluse), la base EWA est une des bases de données hydrologiques existantes les plus étendues. Dans la contribution suivante, Manéa présente l'implantation, par le Groupe AMHY, d'un système de base de données orientée-objet, qui a montré qu'il fournissait des moyens plus efficaces et plus rapides pour la gestion des données hydrologiques. Breil, dans la contribution suivante, résume brièvement le contenu de la base de données AMHY spécifique (outre EWA et les bases nationales) qui comprend, entre autres et pour les seules séries temporelles continues, 244 stations hydrométriques et 92 pluviométriques. La quatrième contribution, d'Andrews, présente la base de données du Groupe FRIEND d'Afrique australe. Elle contient les débits journaliers de presque 700 stations dans 11 pays de la région. Une base complémentaire, d'usage aisé et de données spatiales à l'échelle régionale, y a été développée et comprend des limites de bassins, des données géologiques, hydrogéologiques et de zones humides. Les deux contributions suivantes, par Boyer *et al.*, fournissent des détails sur la base de données BADOIE du Groupe FRIEND d'Afrique Occidentale et Centrale, qui a été développée sous système PC. La première présente l'architecture et le mode de fonctionnement de la base. La seconde en résume le contenu, qui comprend des débits de 522 stations et des pluies de 1120 postes de la région. La dernière contribution, Brilly, traite de l'application de SIG pour l'hydrologie en général, et pour le projet FRIEND en particulier. Quelques brèves remarques sont proposées in fine en conclusion.

The FRIEND European Water Archive

La base de données hydrologique européenne EWA du projet FRIEND

H.G.Rees

1 Introduction

The FRIEND European Water Archive is central to the research activities of the Northern European FRIEND project. Comprising spatial data and time-series data for over 5000 river gauging stations in 26 European countries, the Archive is one of the most extensive hydrological datasets in existence. The archive, which is located at the Institute of Hydrology Wallingford, comprises two distinct elements: a geographical information system (GIS), and a relational database management system (RDBMS). The GIS used is ARC/INFO from the Environmental Systems Research Institute (ESRI), USA. With ARC/INFO, spatially referenced data (thematic and map-derived data) are stored as coverages. Coverages can be readily combined, compared and correlated with each other, thus providing a valuable tool for hydrological analysis. The coverages currently held include :

- topographic catchment boundaries for over 2,000 catchments in northern Europe;
- hydrometric region and area boundaries for the whole of Europe;
- a pan-European river network;
- a soil map of the European Communities;
- gridded maps of EU land-use (forest, urban, lake);
- gridded maps of average annual rainfall, potential evaporation and actual evaporation;
- coastlines and national boundaries for all European countries.

The relational database component of the Archive is based on the ORACLE relational database management system. The data, which are stored on a series of separate, yet related, database tables, include the following:

- 109,000 station-years of gauged daily flow data (measured in m^3s^{-1}) for over 4,200 gauging stations in 25 European countries, (see Table 1);
- gauged monthly flow data for a further 60 stations in Iceland, Poland, Luxembourg and Russia;
- 38,000 station-years of annual instantaneous maxima (flood maxima) for over 2,100 gauging stations in northern and western Europe;
- gauging station details (station number, river name, site name, station coordinates, altitude etc.);
- catchment characteristics (area, average annual rainfall, mean altitude, percentage of catchment which is urban, forest or lake etc.) ;
- derived statistics (mean flow, base flow index (BFI), 95 percentile 1-day flow (Q95), mean annual minima (MAM) etc.).

For the regional analysis of the FRIEND project, both elements are routinely used in conjunction. However, the development of the time-series database represents a considerably greater investment of time and resources and, consequently, the remainder of this paper focuses on the management aspects of this element in particular.

Table 1 : Summary of gauged daily flow data on the FRIEND European Water Archive
Table 1 : Récapitulatif des débits journaliers présents sur la base européenne FRIEND EWA

Country	Number of Stations	Earliest Record	Latest Record	Station years	Record Length (Years)	
					Mean	Max
Austria	82	1951	1990	2502	31	40
Belgium	76	1929	1994	823	11	54
Bulgaria	3	1978	1986	27	9	9
Czech Republic	28	1887	1993	1471	53	104
Denmark	35	1917	1994	1979	57	78
Finland	69	1847	1991	3420	50	144
France	1335	1863	1992	29780	22	128
Germany	520	1908	1994	15948	31	83
Greece	2	1978	1980	6	3	3
Iceland	8	1932	1994	386	48	61
Ireland	67	1940	1996	1543	23	56
Italy	252	1925	1990	3969	16	66
Netherlands	25	1901	1994	581	23	93
Norway	196	1871	1995	6914	35	114
Poland	30	1955	1992	763	25	36
Romania	33	1838	1990	1155	35	153
Russia	12	1932	1988	500	42	57
Slovakia	23	1930	1992	1443	63	63
Slovenia	12	1945	1990	300	25	45
Spain	240	1912	1989	3336	14	74
Sweden	66	1907	1992	2583	39	85
Switzerland	76	1904	1992	2815	37	82
Turkey	7	1975	1987	77	11	12
UK	1031	1879	1995	27133	26	117
Yugoslavia	5	1978	1990	63	13	13
Total	4233			109517		

2 Gauging station selection

To achieve the objectives of the FRIEND project, good quality long-term data is required for the analysis. The criteria for gauging station selection are nominally set as follows:

- the catchment area should not exceed 500 km²;
- there should be a complete daily flow record of 10 years (or more);
- the flow regime should approximate to natural conditions, that is the effect of artificial influences (effect of hydropower, water supply reservoirs, abstractions and discharges, groundwater pumping, etc.) should be less than 10% of the mean flow;
- no significant influence from glaciers.

In practice, there is some relaxation of these "rules". For instance, data for catchments of area greater than 500 km² and some with flow records of less than 10 years can be found on the Archive. The onus is on FRIEND researchers to select catchments that are suitable for their own analyses.

3 Gauging station numbering

Each gauging station on the Archive is allocated a unique FRIEND station number (FID). The FID comprises seven digits and is structured so that a station's general location can be obtained from it. The first two digits define the hydrometric region, the next two define the hydrometric area, and the last three digits contain the sequential number of the station within the hydrometric area. The sub-division of the FRIEND study area into major hydrometric regions derives from the approach adopted in the European Flood Study (Beran, *et al.*, 1984). Boundaries for hydrometric regions and hydrometric areas generally follow topographic boundaries and natural drainage divides rather than international borders. Each region typically contains 10 to 15 hydrometric areas of up to 10,000 km².

A criticism of the FRIEND numbering convention is that it does not give a systematic representation of the structure of a river network. This can cause difficulty when trying to identify which catchments are nested within others. A method to overcome the problem has been developed at the Institute of Hydrology (Gustard, 1993) using a reference matrix in ARC/INFO but this is by no means ideal because the relationship between each and every catchment within a network must be entered manually. Alternative numbering conventions have been considered but none can be applied without a great deal of time and effort.

4 Database tables, views and indexes

The relational database component of the European Water Archive is based on the ORACLE RDBMS. In an RDBMS, data are stored on user-defined database tables in rows and columns. Tables are related to each other by attributes (columns) that are common. Views are used as a convenient method of querying the database, effectively providing windows onto selected rows and columns thus obviating the need for complex queries. In terms of storage, the database tables of the European Water Archive occupy approximately 1.2 Gbytes of disk space. With such a vast amount of data stored, it is important that facilities exist to enable quick access to the data. In ORACLE, this is achieved through the use of indexes which provide direct access to rows in a table and can be used to both speed up data retrieval and to check for uniqueness of an attribute or any combination of attributes. The storage requirement for the Archive's indexes is currently over 950 Mbytes.

5 Managing the Archive

5.1 Data centres

The development and maintenance of the European Water Archive is the overall responsibility of the FRIEND Database project group, coordinated by the Institute of Hydrology. The group has formal responsibilities, defined by the FRIEND Steering Committee, for the following:

- coordinating data acquisition
- maintaining the archive
- applying quality control procedures to the data
- supplying data to groups actively involved in FRIEND research
- liaising with other FRIEND groups
- keeping abreast of new technology and database management techniques

Five Regional Data Centres (RDCs) have been established across Europe to assist in the acquisition of data for the FRIEND project. The Centres (shown in Figure 1) play a key role in updating the Archive, with each having responsibility for contacting and obtaining data from data providers within a region.

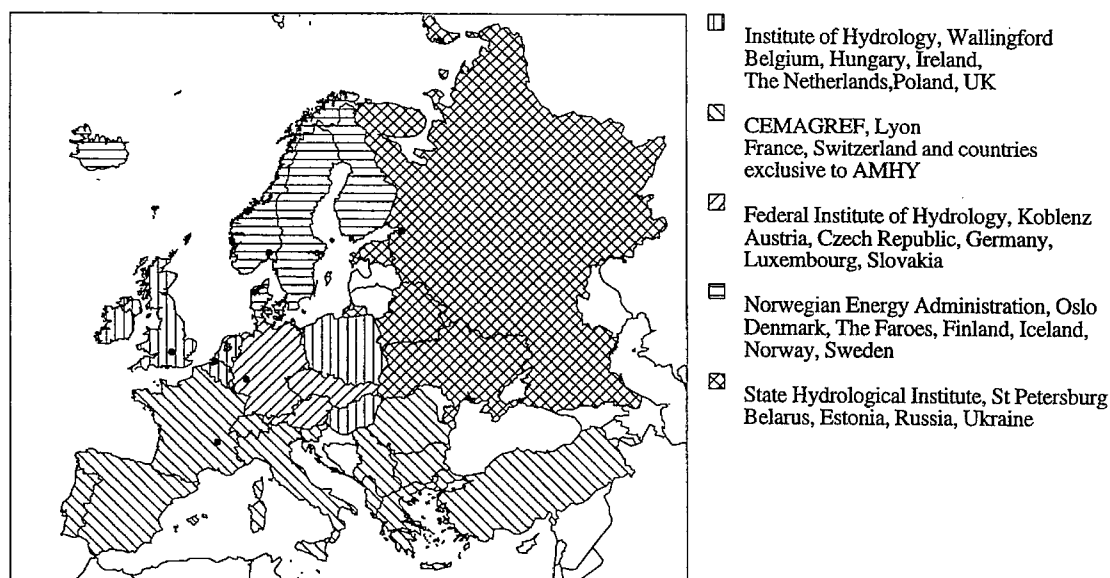

Figure 1 : Regional Data Centres of the FRIEND European Water Archive

Figure 1 : Centres régionaux pour la base de données européenne FRIEND EWA

6 Data transfer

The FRIEND project relies on the voluntary data contributions of the hydrometric agencies (data providers). The Database Coordination Centre can receive data on a variety of media including 9-track ½" magnetic tape (1600 or 6250 bits per inch), 5mm DAT (Digital Audio Tape) tape cartridges, Exabyte (8mm) tape cartridges, diskettes (3.5" floppy) or via the Internet. Data providers are actively encouraged to provide the data in a standard prescribed format. This enables the data to be loaded quickly and efficiently onto the Archive using existing software. Data is normally loaded by using either SQL (structured query language) embedded within FORTRAN source code or ORACLE's SQL*LOADER facility.

7 Quality control

In principle, the responsibility for the quality of the data lies with the hydrometric agencies which provide the data. Generally, it is assumed that the data has been quality controlled before it is forwarded to the FRIEND project. Despite this, a considerable amount of effort is made to ensure the integrity of the data held on the Archive and simple checks are carried out on the data before they are loaded onto the Archive. The most effective technique used is the visual checking of hydrographs where problems with the data are immediately evident. The most common problems encountered are unexpected peaks or troughs, steppy profiles and missing values. The incorrect allocation of FRIEND station numbers also gives rise to difficulties with data for one station being mistakenly attributed to another. Where new data for a station are concurrent with (or follows) existing data for the same station, a visual comparison of the hydrographs is the simplest way of checking for data consistency. Errors in data consistency are most commonly attributed to values being given in different units of measurement. Another useful check is the comparison of mean annual runoff for a catchment with the catchment average annual rainfall. This check can reveal errors in the time-series data and/or the catchment characteristics (area or rainfall). Errors discovered during quality control are referred back to the relevant hydrometric agency and rectified before the data are loaded onto the Archive.

8 Querying the database

ORACLE's structured query language (SQL) provides an easy-to-use interactive method of analysing and reporting on the data stored on the Archive. For complex analysis of the data, SQL can be embedded in FORTRAN programs by using the PRO*FORTRAN pre-compiler. As well as its own toolset, ORACLE also operates with a large collection of third-party software products including ARC/INFO, dBase and Lotus 1-2-3.

9 Data Distribution

Data held on the European Water Archive is freely available to participants of the Northern European FRIEND project on the strict condition it is used solely for research within the FRIEND projects. Requests for data may be made directly to the Database Coordination Centre or via Regional Data Centres (who also hold a sub-set of the Archive). Each request is responded to as quickly as possible depending on current work-load and the nature of the data being requested. All requests are given equal priority and are dealt with on a "first come, first served" basis. A metadata catalogue describing the contents of the Archive is available to assist researchers in selecting the data they require.

The data can be supplied on 9-track magnetic tape, DAT/Exabyte tape cartridges, floppy disks, or via Internet. Spatial data are generally forwarded as ARC/INFO export files while ORACLE based data can be forwarded in either ASCII (American Standard Code for Information Interchange) file format or as ORACLE export files. Supporting documentation is provided with every data set distributed. All data is supplied free-of-charge, although in some instances recipients may be asked to supply an appropriate number of replacement media.

While quality control procedures are employed on the data, the Coordination Centre does not guarantee the validity and accuracy of the data. Recipients who detect errors in the data are asked to report them to the Database Coordination Centre, which will then take appropriate measures to rectify the data with discourse, if necessary, to the original data provider.

10 Conclusions

Although the European Water Archive is well established, continual advances in new technology means there is always scope for it to be improved. Developments in software, hardware and telecommunications are all likely to have a significant effect on how the Archive is to be developed and maintained in future. The proliferation of the World Wide Web, is a prime example of how new technology can generally benefit society and its perspective on computers and digital data. It is important, for the future success of the FRIEND project, that the Database project group, and the Coordination Centre especially, is fully aware of such technological developments and applies them, where appropriate, to the Archive.

Adequate DBMS tools

Les outils de modélisation adéquats des systèmes d'information

A. Manea

1 Introduction

Ces dernières années, la modélisation de systèmes d'information hydrologiques et environnementaux et les applications de bases de données deviennent de plus en plus importantes et complexes. Dans ce contexte, où la quantité d'information augmente et se diversifie, où les approches utilisateur se multiplient et où des nouvelles technologies s'imposent, le processus de conception des schémas de bases de données est de plus en plus difficile et laborieux.

La demande des utilisateurs s'oriente de plus en plus vers des systèmes capables de leur offrir une modélisation fidèle à leur univers (le monde utilisateur) et de meilleures performances (le monde système).

La passerelle entre ces deux mondes est réalisée par le schéma conceptuel qui récupère toutes les informations du monde réel et les formalise en vue de leur implantation dans un système informatique donné. Les modèles sémantiques occupent une place très importante dans la modélisation conceptuelle des systèmes d'information, grâce à leur possibilité d'abstraction et d'assimilation d'un grand nombre de renseignements.

2 Modélisation des systèmes d'information

2.1 Généralités

La modélisation d'un système d'information et le développement d'une application de Bases de Données (BD) supposent la construction d'un modèle conceptuel du système à réaliser. Ce modèle doit être la transcription de la partie du monde réel qui sera gérée par l'application. Un modèle de données est un formalisme pour décrire des données. Il sera manipulé à l'aide d'un ensemble d'opérations.

Le processus de modélisation des systèmes d'information doit tenir compte de l'intégration de structures de données et d'objets de plus en plus complexes et hétérogènes. L'immense volume de données manipulé, la complexité grandissante des applications ainsi que la multitude des domaines concernés, la demande de couplage entre les Systèmes de Gestion de Base de Données (SGBD) et les Systèmes d'Information Géographiques (SIG), la réduction de la durée du cycle analyse - conception - développement, représentent des paramètres dont une méthode de modélisation doit tenir compte.

Le modèle orienté objet favorise la modélisation des systèmes d'information d'une manière naturelle, par l'utilisation des structures complexes. L'utilisation de la technologie orientée objet permet que la modélisation de l'information soit en concordance avec les besoins de l'application.

Les bénéfices du passage aux techniques orientées objet dans la gestion de données sont multiples (Keller, 1994) ; en particulier elles accélèrent le développement, améliorent la maintenance et les performances.

2.2 Le processus de conception orientée objet des systèmes d'information

La modélisation d'un système d'information commence par une étape d'analyse du sujet et par des entretiens avec des experts du domaine, suite à laquelle on obtient un certain nombre de spécifications

semi - formelles ou formelles, textuelles, graphiques, etc. Le but recherché est d'assimiler toutes ces informations dans un schéma de base de données et de l'implanter dans un SGBD.

Ce processus est réalisé en plusieurs étapes :

L'analyse des besoins doit fournir le plus d'informations possibles pour modéliser correctement un système d'information : les données à stocker et leur structure, les interactions entre les différentes parties du système. A la fin de cette étape, une première spécification abstraite du système est formulée.

Le processus de conception continue avec la création du schéma conceptuel ; ce schéma est indépendant du SGBD utilisé. Pour définir le schéma conceptuel on utilise un modèle conceptuel, tel que Entité - Association (EA) (Fahrner, 1995a) ou autre modèle sémantique (Graphe Sémantique Normalisé, par exemple). Plus récemment, des méthodes d'analyse et de conception orientées objet des systèmes d'information utilisent des démarches spécifiques.

La troisième étape consiste à traduire le schéma conceptuel en un schéma logique, utilisant un modèle cible (le modèle réseau, le modèle hiérarchique, le modèle relationnel, le modèle orienté objet), compris et utilisé par un SGBD.

Il y a beaucoup de méthodes orientées objet d'analyse et conception dans la littérature, mais il n'y a pas encore de consensus ou de standardisation.

Certains auteurs mettent l'accent sur les méthodes d'analyse, autrement dit sur la modélisation du domaine de l'application étudiée ¹ : Shlaer & Mellor (Shlaer, 1988), O* (Brunet, 1993). Ils se concentrent sur l'abstraction des objets du domaine, la définition de leur structure et la mise en évidence des relations entre ces objets.

D'autres auteurs (Booch, 1992) introduisent des approches ciblées sur des méthodes de conception et de développement². Cette démarche suppose que les objets significatifs ont été déjà identifiés et met l'accent sur le comportement d'un objet, ce qui conduit à affiner et réorganiser les classes, à améliorer la réutilisabilité et à profiter de l'héritage.

Il y a une troisième catégorie de méthodes orientées objet qui s'intéressent aussi bien à l'analyse, qu'à la conception et au développement : OOA : Coad & Yourdon (Coad, 1999), Classe - Relation (Desfray, 1993), OMT (Rumbaugh, 1991).

Certaines méthodes sont plutôt prescriptives (exemple : Booch), d'autres plus formelles (exemple : Shlaer & Mellor ou Classe - Relation). Pour certaines méthodes l'acquisition des informations est bien définie dans le temps (l'étape d'analyse pour Shlaer & Mellor), pour d'autres elle est diffuse sur l'ensemble du cycle analyse - conception - développement (Booch, OMT).

Rarement, l'usage du système (les traitements et les performances souhaitées) est pris en compte dans le modèle de représentation statique. Le modèle O* utilise un concept de point de vue comme critère de choix pour la structure statique de la classe.

Une grande partie des concepts et des termes utilisés sont propres à chaque méthode. Même si au niveau du modèle statique on a, dans la majorité des cas, les mêmes concepts de base, il y a aussi des différences, par exemple l'utilisation du concept de lien de composition (présent dans : OOA : Code & Yourdon, O*, OMT) ou celui de rôle d'un attribut (présent dans OOA).

Dans la totalité des cas il est très difficile d'identifier les classes et les objets significatifs pour le système d'information modélisé : cette étape n'est pas formalisée, varie d'une méthode à l'autre et demande de suivre une pléthore d'heuristiques et d'indications. Booch (1992) fait une analyse détaillée du domaine, des sous - domaines et des sujets, essayant d'identifier les objets impliqués d'une manière itérative et plus précise. Shlaer (1988) suggère que les objets peuvent être identifiés parmi les choses concrets, les rôles des personnes ou d'organisations, les événements ou les interactions, en mettant un fort accent sur les associations et les relations, de même que Rumbaugh

¹ analyse = le processus d'extraction et de codification des demandes utilisateur dans le but de définir un modèle précis du système étudié

² conception et développement = le processus de transformation des spécifications en une implantation dans un système spécifique, conformément aux coûts, aux performances et aux paramètres de qualité désirés.

(1991). Coad (1990) recommande de chercher les objets parmi les structures, les sites, les rôles, les choses ou les événements et met en évidence la description des structures.

3 Le modèle orienté objet

Les modèles Orientés Objets (OO), en plus de leurs propres caractéristiques, héritent des modèles sémantiques, des systèmes à objets complexes et d'autres techniques informatiques avancées (**modularité, liaison dynamique et tardive**, etc.). Le modèle orienté objet (Delobel, 1991) met l'accent sur l'**encapsulation** dans le concept d'objet à la fois des données et des opérations possibles sur ces données (traitements). Il offre un mécanisme **d'héritage** qui organise mieux les classes d'entités, et développe des **systèmes extensibles**. La notion d'identité d'objet est une propriété intrinsèque du modèle. L'**identité objet** identifie une unité d'information individualisée qui est constante dans le temps et indépendante des modifications qui peuvent intervenir ; elle permet aussi le partage de l'information.

Une définition simple du modèle Objet est (Cattel, 1994), (Delobel, 1992) :

A la base de la modélisation est l'**objet**. Les objets peuvent être classifiés par des **types**. Les types sont connectés dans un graphe sous-type/supertype (héritage). L'ensemble de toutes les instances d'un type est nommé son extension. Chaque type définit un ensemble de propriétés et/ou un ensemble d'opérations. Les propriétés (attributs et associations) décrivent **la structure** du type. Les attributs décrivent les caractéristiques locales du type. **Les associations** sont des propriétés de type référence, qui définissent les liens entre deux objets de type différent ; ces liens sont mono ou multivalués. Les opérations décrivent **le comportement** des objets appartenant au type.

Le modèle objet permet la manipulation des structures complexes :

Structure complexe :: Collection | Tuple

Collection :: Ensemble | Amas | Ensemble ordonné | Liste

Les structures complexes sont construites de façon libre à partir de Tuple et Collection.

Les structures de données complexes

Le processus de modélisation des systèmes d'information doit tenir compte de l'intégration de structures de données de plus en plus complexes et hétérogènes. Le modèle relationnel ne peut plus répondre à cette tâche. Le n-uplet, le type de donnée utilisé par le modèle relationnel, n'est pas apte à intégrer cette complexité grandissante. Pour cette raison, l'utilisation des structures de données complexes dans la modélisation des systèmes d'information, s'impose. Une donnée complexe est une structure hiérarchique qui est construite itérativement à partir du n-uplet et des constructeurs ensemblistes.

Une **donnée complexe** est défini comme une structure d'attributs :

attribut : *attribut simple* ou *attribut complexe*

attribut simple : char ou integer ou real ou string ou image ou text

attribut complexe : collection (attribut) ou tuple (attribut1 { ,...,attributi })

collection : set ou set unique ou liste

Les constructeurs (tuple, set, liste) sont orthogonaux (ils peuvent être appliqués à n'importe quel objet). Les constructeurs (tuple, set) du modèle relationnel ne sont pas orthogonaux : un tuple s'applique seulement aux valeurs atomiques, un set s'applique seulement aux tuples.

La valeur d'un attribut d'objet peut être un autre objet ou une structure complexe. Dans le cas de l'attribut objet, la valeur est un OId (Object Identifier). Si le système supporte les attributs de type de donnée complexe (exemple : le SGBD O₂), la valeur complexe est stockée dans l'attribut.

Les données complexes incluses dans d'autres structures de données sont propres aux objets auxquels elles appartiennent. Elles n'ont pas d'existence indépendante (donc pas d'identité propre). et ne peuvent pas être partagées par d'autres objets.

4 La Base de Données FRIEND - AMHY

Le projet FRIEND - AMHY est un projet international, multidisciplinaire, de recherche et développement dans le domaine de l'environnement. Un des thèmes de ce projet concerne la conception et l'implémentation d'une base de données, utilisant les techniques informatiques les plus évoluées et qui doit répondre aux besoins spécifiques du domaine.

Les contraintes sont multiples : l'immense volume de données à manipuler, l'utilisation de données hétérogènes (numériques, cartes, images, etc.), la nécessité de développement des traitements cartographiques et l'implémentation d'algorithmes scientifiques avancés, la gestion et la manipulation des **chroniques**.

L'utilisation du modèle objet est apparue naturelle compte tenu de la complexité et des contraintes du système à modéliser, mais il fallait assurer une conception cohérente et surtout optimale par rapport aux attentes des utilisateurs : flexibilité, accès rapide, extensibilité, etc.

Un type d'information utilisé par les systèmes hydrologiques et environnementales est l'information signalétique. Cette information représente un volume faible, mais est fondamentale pour discriminer, traiter et critiquer les échantillons de données.

L'entité la plus importante est celle de **Station**, autour de laquelle s'organise les autres informations : *Project*, *Participant*, etc. Une station de mesure est en même temps un lieu géographique (en liaison avec des applications cartographiques et topographiques), un (ou des) instrument(s) de mesure (la gestion d'appareillages et des caractéristiques métriques), et un dictionnaire de critères de classification pour les chroniques.

Ces catégories d'information représentent des points de vue différents du même objet, qui coexistent, communiquent et ont un comportement unitaire.

Exemple : une étude scientifique ou statistique sur des chroniques de mesure a besoin de critiquer les résultats par rapport aux instruments utilisés ou à la position géographique (nature du terrain, altitude, etc.). Certaines informations n'ont de sens que dans un contexte d'ensemble : les mesures effectuées perdent toute signification si elles sont coupées des autres informations (caractéristiques générales de la station, l'appareillage utilisé, le type de paramètre mesuré, etc.).

5 La modélisation du type de donnée CHRONIQUE par des structures complexes

Le type de données le plus fréquent en hydrologie est la **chronique**, soit un ensemble ordonné de couples (valeur, date), ou *valeur* exprime numériquement la mesure effectuée par un capteur sur le terrain et *date*, la date de la mesure. Il existe donc une relation d'ordre total qui structure ces données, par l'intermédiaire de *date*. Ce type de données représente la plus grande masse (plusieurs Go) à traiter par un Système de Gestion de Bases de Données (SGBD) (Manea, 1995).

Le modèle relationnel a permis une évolution significative en ce qui concerne la gestion de données. En Hydrologie malheureusement, les contraintes de la première forme normale ont conduit à «déstructurer» les chroniques de données en n'exploitant plus la relation d'ordre chronologique naturelle. Ceci conduit à des Bases de Données peu performantes, et nécessitant un gros espace de stockage (due à une forte explicitation de l'information).

Le modèle orienté objet et surtout, le type d'objet complexe, offre la possibilité de définir une chronique d'une manière naturelle et optimale. Les tests réalisés (Manea, 1993) montre d'une façon évidente l'avantage de la modélisation des chroniques par modèle orienté objet (complexe).

Le cas des chroniques met plus en évidence le lien de composition et la relation composant - composé. Une chronique de mesures appartient à une station précise ; elle n'a pas de signification, d'identité ou de comportement propre, en dehors de la station. Il est bien évident qu'un ensemble de valeurs de mesure ne peut être étudié et interprété que dans le contexte d'une station : position géographique, caractéristiques générales du paramètre mesuré (unité de mesure, type de mesure, etc.), appareillage utilisé. Semblablement, l'ensemble de valeurs représentant les mesures effectuées pendant un certain mois, est cohérent que lié à l'année et respectivement à la station de mesure.

Les chroniques représentent un volume très important d'information. Elles demandent l'optimisation du stockage et des accès, en même temps que le développement d'applications scientifiques spécifiques.

Si on prend comme exemple de chronique, les débits d'eaux mesurés à une station hydrologique pendant trente années, avec un pas de temps de 6 minutes, on arrive à presque 3 millions de couples (date, valeur) qui doivent être enregistrés et traités.

Dans une modélisation relationnelle, avec la contrainte de la troisième forme normale, on va stocker pour chaque valeur enregistrée, l'ensemble (année, mois, jour, heure, minute), ce qui conduit à une très forte redondance. Pour les chroniques, il est très important de pouvoir exprimer le fait qu'un objet est un composant d'un autre (par exemple, un mois est un composant de l'année), et qu'il ne peut pas exister en dehors de l'objet composite (les mesures enregistrées, par exemple pendant une semaine, n'ont de sens que si elle sont considérées dans un contexte temporel complet : années, mois, etc.).

Pour les chroniques, la dimension «temps» est très importante ; elle établit une relation d'ordre sur l'ensemble des mesures, d'où une modélisation hiérarchique de ce type de donnée. L'optimisation du stockage des chroniques est très importante, par le fait qu'elles représentent un volume important de données (plusieurs Go dans une base de données courante). Les applications ne visent pas de sélections ponctuelles, mais traitent une ou plusieurs chroniques dans leur ensemble. Pour ces raisons, minimiser la redondance des l'information et optimiser les structures pour un meilleur accès deviennent des objectifs essentiels dans la modélisation d'un tel type de système.

Dans (Manea, 1993), plusieurs modélisations ont été utilisées pour le même type d'information : un ensemble de chroniques de débits ayant un pas de temps de l'ordre de la minute correspondant à un ensemble de stations de mesure (Figure 1). Le cas (a) correspond à une modélisation relationnelle, (b), (c) et (d) à différentes modélisations orientées objet.

Première constatation : pour ces configurations, l'espace de stockage nécessaire pour une base de données relationnelle est jusqu'à trois fois plus grand que pour une base de données orientée objet. Deuxième constatation : l'accès à l'information est beaucoup plus rapide en utilisant des structures complexes et hiérarchiques. L'explication réside dans le fait qu'une structure complexe, minimise la redondance en factorisant l'information et accélère l'accès par la répartition de l'information sur plusieurs niveaux, chaque niveau bénéficiant d'un (au moins) critère de sélection (*StationCode*, *Year*, etc.).

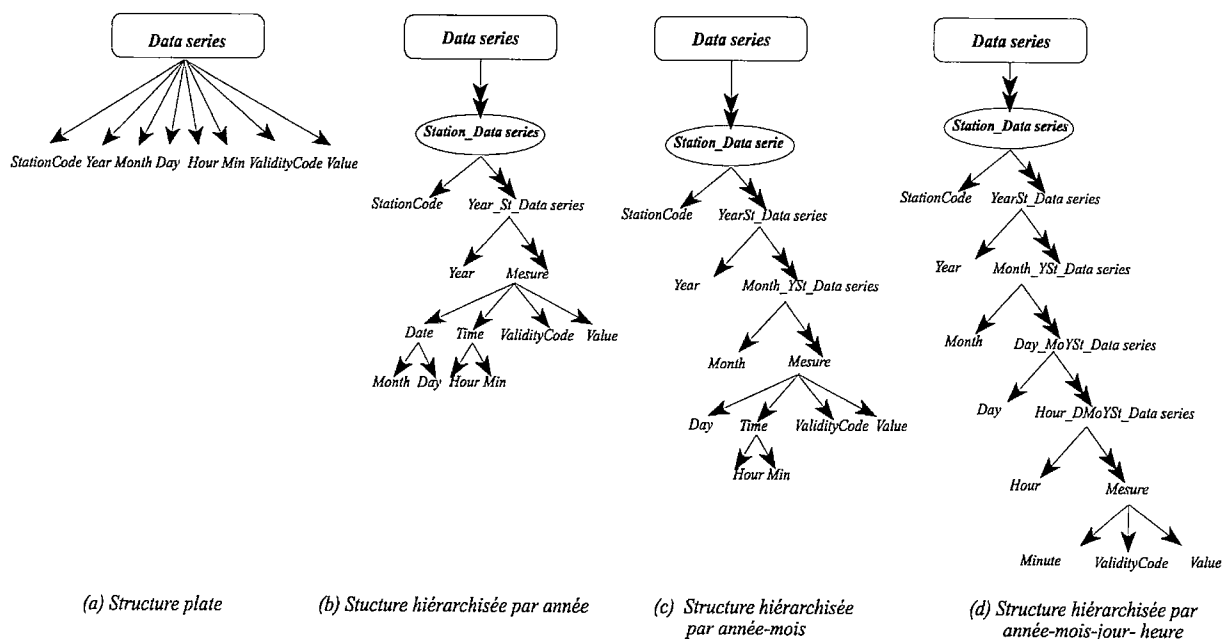

Figure 1 : Modélisation de chroniques hiérarchisées

Figure 1 : Hierarchical timeseries design

Data selected for the AMHY database

Données sélectionnées de la base AMHY

P. Breil

1 AMHY database objectives and history

The initial objective of the selection was to include only specific data devoted to AMHY topics with the aim of limiting data management and to focus on data quality rather than quantity. This means that regionalization of hydrological characteristics is usually undertaken by each collaborating country using their own national data network for their required national applications. Data is mostly provided by participating countries, with a smaller amount from the Global Runoff Data Center (GRDC), Koblenz. The AMHY database was set up progressively from 1992, using a common format for discharge and rainfall time series in order to conduct an initial check. The second step, performed some months ago, imported these data into an Oriented Object Data Base Management System (OODBMS). A Web site offers a welcome page to all users and data base consultation/extraction to users with password permission. The address of the web site is: "<http://www.lyon.cemagref.fr/~manea/amhyth1>".

2 AMHY data specifications

The AMHY database comprises 244 daily discharge stations and 92 daily rainfall stations. Thirty nine stations are coupled data for rainfall-discharge hydrological model applications. The number of station/years of data are 6458 for discharge data and 2836 for daily rainfall data.

Due to a wide variety of spatial scale for hydrological applications, a daily time step was retained as a good compromise to characterize hydrological processes of interest for regionalization. However, for small areas with specific problems like high basin gradient and quick flood generation, a refined time step was included in the database for a set of 40 records of coupled rainfall-discharge data.

The station numbering scheme from the Northern European FRIEND database was used to ensure coherence with the AMHY discharge time series and to avoid redundant codes. For rainfall data (not included in the NE FRIEND database), codes were attributed in the usual way. Other specific data were sent to the AMHY group. There are extreme values from time series both for discharge and rainfall with a wide range of sampling time steps (from minute to month). These data will be included directly in the AMHY OODBMS.

Up to the present time, data has been used by researchers in Romania (for flood regionalization), Spain (flood probability), Italy (rainfall regionalization), and France (flood probability and regionalization, rainfall probability and long series). They provided 75% of daily discharge stations and 75% of daily rainfall stations.

Mean annual flow values were calculated using daily data. Statistics for flow ranging from 36 to 2447 mm per year and rainfall from 375 to 2334 mm per year. Figure 1 shows the behaviour between annual flow and elevation. Note that alpine and mediterranean areas provide a wide variety of flow regimes, mainly based on rainfall-snowmelt mixed regimes, mediterranean rainfall influences, island effects and very dry seasons. Figure 2 shows a mean duration of thirty years for frequency analysis, with some long record stations for extreme discharge characteristics models assessment. There is also a wide range in discharge station areas both to integrate complex flow regimes and scale effects on discharge characteristics.

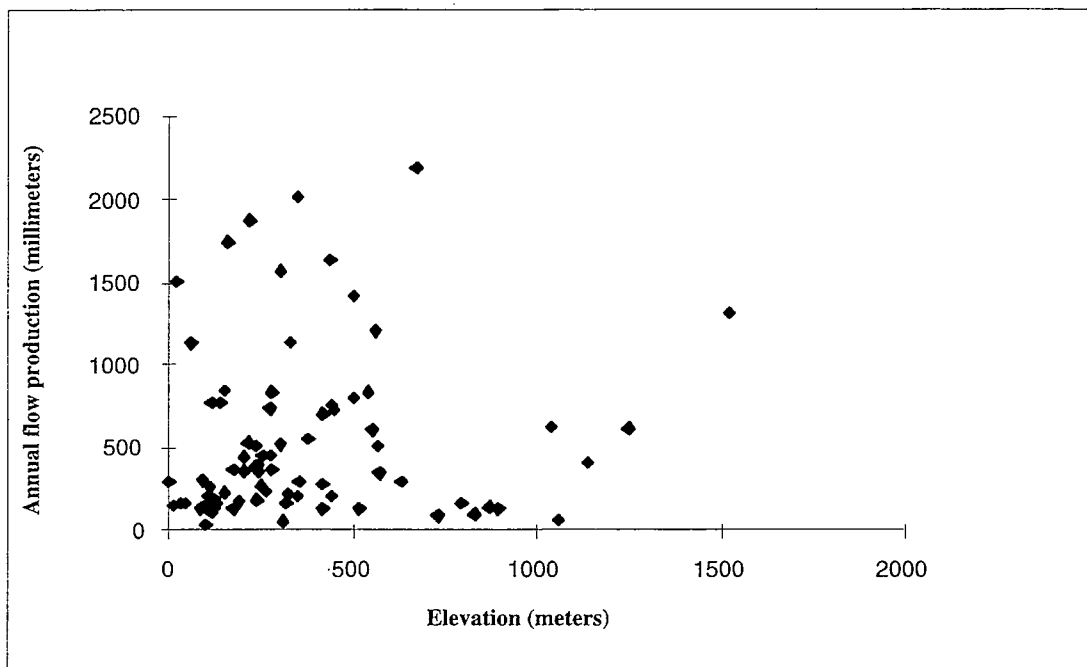

Figure 1 : Alpine and mediterranean annual flow range production with station elevations (from a set of AMHY-base daily discharge stations)

Figure 1 : Plage de variation des écoulements annuels en zone alpine et méditerranéenne, selon l'altitude de la station hydrométrique

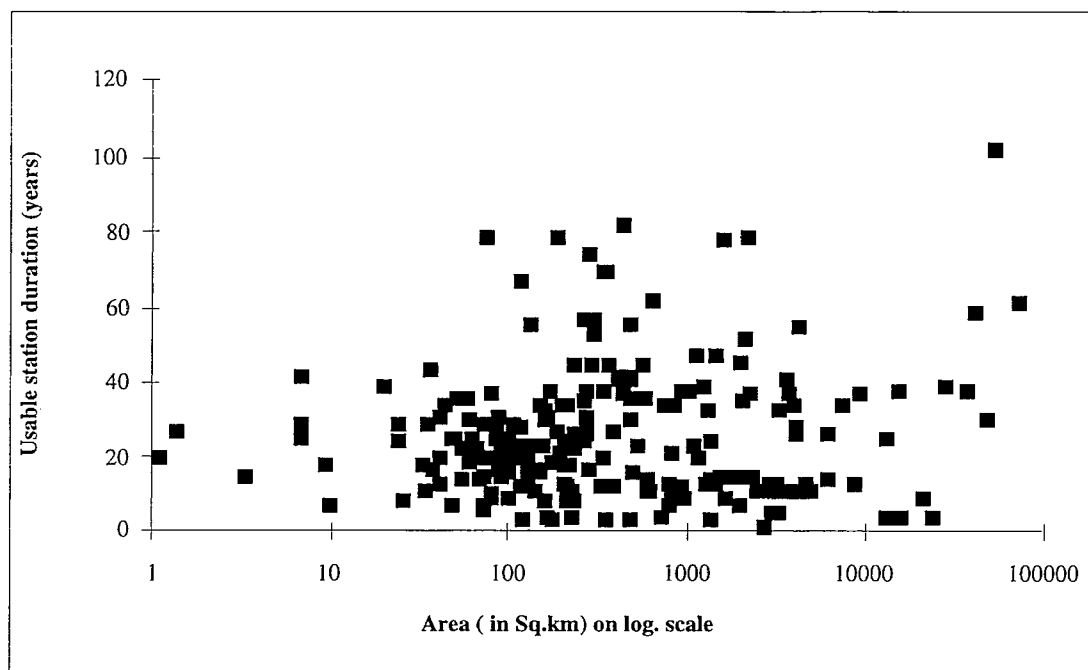

Figure 2 : AMHY data base distribution, discharge durations versus station areas

Figure 2 : Distribution des durées observées, selon l'aire des bassins versants

The Southern African FRIEND database

La base de données FRIEND Afrique Australe

A. J. Andrews

1 River flow archive

1.1 Introduction

The principle objective of the River Flow Data Base Project, co-ordinated by the Institute of Hydrology and the University of Dar-Es-Salaam, is to underpin the analytical projects by establishing an international data base of river flow on a common hydrological data base platform. This objective placed emphasis on the collation of historic daily flows (as demanded by the low flow analyses and daily rainfall-runoff models) and instantaneous peak discharges (as demanded by the regional flood frequency analyses). It is not the intention of the River Flow Data Base Project to establish an operational networked flow data base for the region.

Daily river flow data was contributed by the National Hydrological Services of each country in the Southern African Development Community (SADC) region and transferred to the Co-ordination Centre at the University of Dar-Es-Salaam where it was loaded onto the HYDATA FRIEND data base and distributed to the research groups. Full description of the Southern African FRIEND River Flow Archive can be found in Andrews *et al.* (in prep.).

1.2 Selection of FRIEND basins

In association with the National Hydrological Services, a Master Register of all gauging stations located in southern Africa was compiled which comprises meta-data for 11,000 stations, although not all stations have processed flow data. The Master Register provided a foundation for the selection of appropriate flow series with data characteristics that meet the selection criteria specific to the demands of the research projects. Questionnaires were used to provide guidelines for the selection of gauging stations which encompassed aspects of data quality, availability and degree of artificial influence.

The selection procedure initially identified 732 gauging stations for inclusion on the FRIEND data base. Variations in data quality across the flow range necessitated a categorisation of data for suitability for research analysis in terms of mean flow, low flows and flood flows. For this purpose, hydrographs for each gauging station were inspected visually for data errors and inconsistencies in the flow record. During this exercise 56 stations were rejected from the data base. Each station was designated a flag denoting whether the station is suitable for low flow, flood and rainfall runoff modelling or some combination of these.

1.3 A common software platform for hydrological data

To assist in the development of a unified international hydrological data base it was realised at the outset that a common purpose built system was required. Such a system would greatly speed access to hydrological data, encourage good hydrological quality checking of data and provide standard data analysis and presentation methods. More importantly, the adoption of a common hydrological data base would facilitate the transfer of hydrological data between countries and greatly assist the

development of a unified international hydrological data base. The River Flow Data Base Project selected the Institute of Hydrology's HYDATA system due to the strong background in the region with five countries already using HYDATA for their national archive system.

1.4 Station numbering scheme

The National Hydrological Services have historically adopted different numbering schemes for gauging stations, with no attempt previously to combine schemes. It was therefore necessary to develop a unifying station numbering scheme for the SADC region that could be used by the FRIEND project. The adopted coding scheme is composed of eight digits which conforms to the maximum number of digits allowed in HYDATA. The eight figure station number is made up of six components comprising a country code, primary, secondary, tertiary and quaternary river basin code, and a unique station number. Application of the new scheme enables rapid identification of all FRIEND stations in a country or river basin, or combination of these.

1.5 Data assembly and validation

The provision of good quality reliable data was the responsibility of the National Hydrological Service. An essential part of the data assembly was the advice given by local hydrologists who are responsible for, and therefore have comprehensive knowledge about, data quality and availability. The Data Base Project was responsible for the transfer of the data from existing data bases onto HYDATA and not the hydrological aspects of quality control.

Simple tests of the data were carried out to ensure that errors introduced during the transfer of data in different formats were minimised. These included the checking of numerical inconsistencies, such as identifying periods with consecutive days showing the same flow or the number of days of missing data. Hydrographs were plotted for each station and the period of record inspected visually. Typical errors identified during this exercise included; truncation of the peak flows, obvious changes in the rating of a section not accounted for in the time series, recessions falling to zero flow for perennial rivers, spikes and troughs in the hydrograph for no reason, period of zero flow when the record is in fact missing.

1.6 Managing the archive

1.6.1 Co-ordination Centre

The data base is stored and managed at the FRIEND co-ordination centre at the University of Dar-Es-Salaam and it is the responsibility of the River Flow Data Base Project to: support the co-ordination centre through the provision of a Data Base Manager; maintain the archive; disseminate the data base to organisations participating on the FRIEND project; liaise with other projects and data base initiatives in the region. The River Flow Archive was considered to be closed towards the end of the first phase of the FRIEND project, with no contingency for updating the data base with recent flows. This closure does not necessarily discount the addition of more recent data during the second phase of the FRIEND project.

1.6.2 Data transfer

River flow data was provided freely by the National Hydrological Services in the SADC region under a data exchange agreement defining the conditions of utilisation of the data during and beyond the life-time of the FRIEND project. The data base was provided during the first phase of the FRIEND project to the three research groups based at the University of Dar-Es-Salaam, Institute of Hydrology and Rhodes University. Dissemination to participating organisations will be facilitated using CD-ROM or the Internet where available. The data will be provided as a fully formatted v3.21 HYDATA data base.

1.7 Content of the river flow archive

The river flow archive comprises data from 11 countries in southern Africa, in nine major basins across a range of climate zones from the sub-tropical in the north to desert in the Kalahari. The eleven countries participating in the Southern African FRIEND project have between them contributed 676 time series of daily flow data which is approximately 15% of the available gauging stations in the SADC region that are, or have been, operational since 1940. The period of record ranges from 1940 to 1992 and equates to 15,190 station years of data with an average of 23 years per station. The number of station years varies from 1 to 51 and the mode of the frequency distribution of record lengths is 27 years.

2 Spatial data base

2.1 Introduction

The development of a regional spatial data base on the ARC-INFO geographical information system (GIS) was identified by the participating countries as one of the core objectives of the Southern African FRIEND project. The direction of the Spatial Data Base Project, co-ordinated by the Institute of Hydrology, was determined by the demand for region-wide, standardised coverages on a common geographical reference system of those thematic factors considered significant in determining flow regimes and extremes. The FRIEND Spatial Data Base will increase the availability of hydrologically relevant data bases for the SADC region and provide catchment specific environmental information to enable hydrologists to generalise and extrapolate research results beyond individual basin boundaries into ungauged regions.

2.2 Derivation and management of spatial data

Generating ARC-INFO coverages for the FRIEND project involved three key stages: the collation of maps and digital data, digitising and editing of vector features, and the allocation of attribute information to polygons and points features. Digitising of maps was carried out on a Calcom digitising table using the ARC Digitising System (ADS). Maps and existing digital data were acquired by the Spatial Data Base Project from National Mapping Agencies, commercial data products on CD-ROM and public domain data accessed over the Internet. The data base is managed by the Spatial Data Base Project Team at the Institute of Hydrology. Dissemination of the data base will be in ARC-INFO export format using a combination of CD-ROM and Internet, depending on the capability of the receiving organisation to handle such media.

2.3 Content of the spatial data base

The FRIEND Spatial Data Base Project has assembled regional ARC-INFO coverages sharing a common projection of 9 types of thematic environmental data which include: integrated river basin, gauged catchment and national boundaries; digital elevation data; river network; precipitation; potential evaporation; wetlands; vegetation cover; soils; geology and hydrogeology. Most effort has been focused on the SADC-wide integrated catchment boundary, geology and hydrogeology and, wetland data sets which were developed from 1:250k scale base maps. Detailed descriptions of all spatial data sets and the attribute schemes can be found in Andrews and Bullock (in prep.).

Underpinning the data base is a single integrated coverage for the SADC region of 500 national hydrometric river basins, over 1000 catchment boundaries including all FRIEND stations, and national boundaries for all 11 countries created from the 1:250,000 topographic maps (excepting 1:500,000 for Angola) of southern Africa. This data set is used to derive spatial indices of environmental information in the form of single number indices or the percentage coverage of a catchment or river basin.

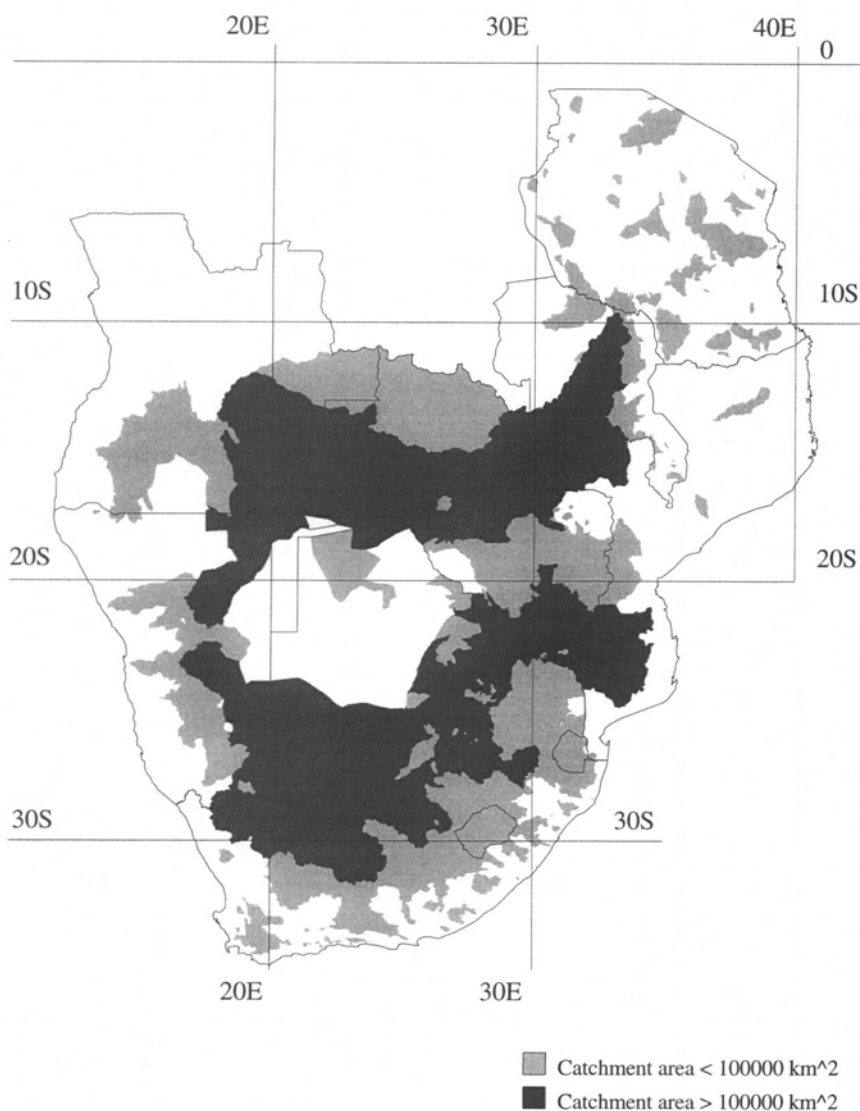

Figure 1 : Area in southern Africa represented by FRIEND catchments

Figure 1 : Zones de l'Afrique australe couvertes par les bassins FRIEND

The upstream catchment boundaries of gauging stations and boundaries of the hydrometric river basins were drawn onto the 1:250,000 topographic maps and digitised. Problems of matching across national boundaries exist in some places, particularly in desert, wetland or pan areas such as the Kalahari Desert and Makgadikgadi Pan in Namibia and Botswana. A river basin data set at 1:250,000 scale for South Africa was provided in ARC-INFO format by the South African Department of Water Affairs and Forestry and was incorporated into the FRIEND coverage. The data set comprises 12561 arcs, 2886 polygons and occupies 7.2 Mbytes. The attribute information contained in the integrated national, river basin and catchment ARC-INFO coverage enables the identification of the location of any polygon in terms of the country of origin, the river basin and the immediate downstream gauging station, or any combination of these. Figure 1 illustrates that approximately 50% of the total area of southern Africa is gauged by the FRIEND stations, with 24% of this area gauged by stations that have an upstream catchment area less than 100,000 km².

The nesting structure of all the FRIEND catchments was compiled manually using a combination of the topographic maps and river network vector coverages. The REGION module of ARC-INFO v.7 is used to automatically select all upstream polygons that constitute the catchment boundary of a gauging station. The ability of REGIONS to handle nested areas facilitates the calculation of the physiographic catchment characteristics.

2.4 Spatial data base sampling and retrieval methods

The main application of the spatial data base during the first phase of the southern African FRIEND project has been the derivation of spatial indices of environmental information in the form of single number indices and the percentage coverage of the catchment area. The spatial data base sampling method involved overlaying the catchment boundary coverage onto each of the thematic coverages. New data sets are created which retain the attribute scheme of the original coverages. The nesting structure of the catchments is retained in the new coverage with the preservation of the region topology of the catchment boundary data set. The method to retrieve a catchment area upstream of any FRIEND gauging station utilises the REGIONS capabilities of the GIS. ARC-INFO Macro Language (AML) and external FORTRAN programmes are written to automate the calculation of the spatial indices of catchment characteristics in the form of the percentage of catchment area.

3 Conclusion

The completion of the River Flow Archive has facilitated the objectives of the three research programmes of the Southern African FRIEND Project and provides data appropriate for sub-national, national and regional studies of flow regimes and water resources assessments particularly for international river basins. The River Flow Data Base Project has made a substantial advance by assembling 676 time series of river flow data from eleven countries onto a single archive for research purposes considering the difficulties associated with the different national archives in southern Africa. The Spatial Data Base Project represents a significant investment of effort during the first phase of the FRIEND project. This has involved the development, management and in some cases unification of new and existing data sets and the application of GIS techniques to derive catchment based spatial indices of environmental data.

Badoie : outil de gestion de la base de données du projet FRIEND AOC.

Badoie : the FRIEND AOC database management tool

J.F. Boyer, C. Berkhoff, E. Servat, J.M. Fritsch

1 Introduction

La base de données des projets FRIEND est un élément fédérateur en ce sens que chacun des pays ou des partenaires de ces projets y contribue dans la mesure de ses moyens. Afin de gérer l'ensemble des données mises en commun au sein de FRIEND AOC, il a été décidé de réaliser un logiciel de gestion de base de données. Ce logiciel, dénommé BADOIE (BASE de DONNÉES Inter-Etats), a été développé avec le SGBD Paradox pour Windows. Il répond à l'ensemble des exigences formulées lors de l'établissement préalable d'un cahier des charges approuvé par l'ensemble des partenaires. Bien que ce gestionnaire de base de données ait été développé pour les besoins spécifiques du projet FRIEND AOC, il peut être utilisé pour de nombreux autres cas de gestion de données hydrométriques et pluviométriques.

2 Données et fonctions

Les données traitées (pluies et débits) sont au pas de temps journalier ou aux pas de temps supérieurs disponibles (pentadaire, décadaire ou mensuel) et correspondent aux besoins exprimés par les différents thèmes de recherche du projet. Ce premier type d'informations appelées informations environnementales, côtoie dans la base les informations dites de fonctionnement. Les informations environnementales sont liées aux données proprement dites. Quant aux informations de fonctionnement, elles constituent les éléments qu'il est nécessaire de conserver pour une gestion dynamique des données (provenance des données, qui les a fournies etc.).

De plus, la gestion des données au sein de la base répond aux besoins exprimés en matière de coexistence de jeux de données différents pour une même station ou un même poste. BADOIE fait la différence entre les données fournies par l'organisme ou le service gestionnaire, considéré comme le jeu de données de référence, et les jeux complétés ou corrigés par les équipes de recherche suivant des méthodes adaptées à leur problématique.

Les fonctions offertes par BADOIE concernant la gestion des informations environnementales sont la centralisation, le stockage ainsi que la connaissance de l'état de la base à l'aide de différentes formes d'éditations et d'inventaires. Les données de fonctionnement permettent à BADOIE d'assurer les fonctions de gestion des mouvements de données en identifiant l'origine et la destination des alimentations et des distributions des données aux partenaires.

L'alimentation de BADOIE se fait préférentiellement à partir de HYDROM et PLUVIOM, gestionnaires de données pluviométriques développés à l'ORSTOM et très largement utilisés en Afrique de l'Ouest et Centrale. Toutefois, de nombreuses autres passerelles sont développées pour permettre l'importation de données fournies dans un format différent. BADOIE peut, par ailleurs, exporter des données sous des formats courants: Excel, Lotus, Quattro et ASCII.

3 Modèle conceptuel des données

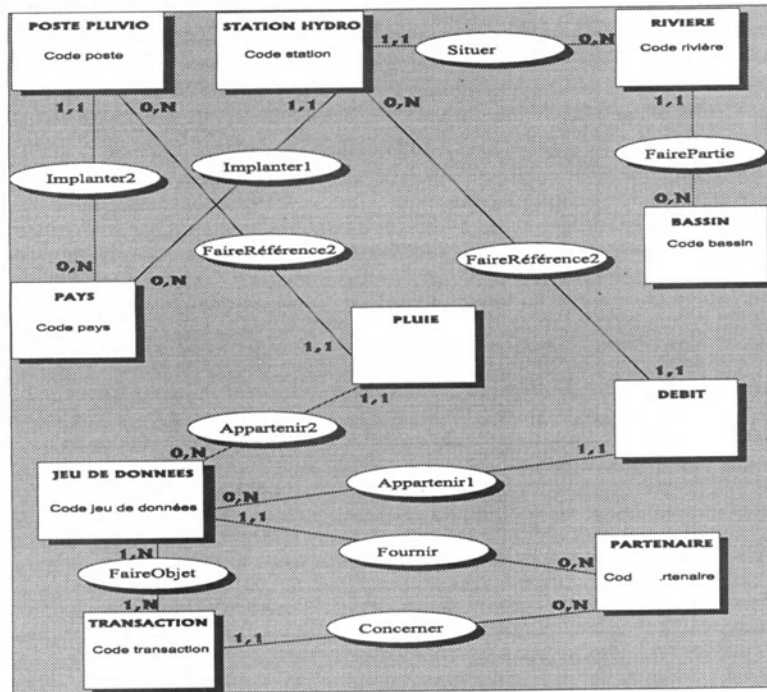

Figure 1 : Modèle conceptuel des données de la base de données FRIEND AOC
 Figure 1 : FRIEND AOC Data base Conceptual model.

La construction du modèle conceptuel est faite par l'identification des relations et des objets déduits du cahier des charges. Ces relations et ces objets sont communs à la plupart des bases de données gérant des pluies et des débits aux pas de temps journalier et supérieurs. En revanche, la gestion des données de fonctionnement contribue à l'originalité de ce modèle. Par déduction du modèle, la base de données se compose de douze tables principales détaillées ci dessous.

Pays Code Pays Nom Pays Fond_de_carte	Rivière Code Rivière Nom Rivière Code Bassin Longueur	Partenaire Code Partenaire Nom Code Responsable	Bassin Code Bassin Nom_bassin Superficie
Poste_Pluvio Code Poste Nom_Poste Code Pays Latitude Longitude Altitude Code_Partenaire Descriptif	Station_Hydro Code Station Nom_Station Code Pays Code_Rivière Latitude Longitude Altitude Code_Partenaire Periode_fonction Superficie Descriptif	Pluie Code Poste Code Jeu Année Mois PluieJ1 OrigineJ1 ----- PluieJ31 Origine31 PluieP1 OrigineP1 ----- PluieP6 OrigineP6 PluieD1 OrigineD1 ----- PluieD3 OrigineD3 PluieM OrigineM	Debit Code Station Code Jeu Année Mois DebitJ1 OrigineJ1 ----- DebitJ31 Origine31 DebitD1 OrigineD1 ----- DebitD3 OrigineD3 DebitM OrigineM
Transaction Code Transaction Code Partenaire Nature Date	Jeu_de_donnees Code Jeu Code Partenaire Date Date_Mise_A_Jour Descriptif Code Jeu Origine	FaireObjet Code Jeu Code Transaction	Responsable Code Responsable Adresse Telephone Telecopie E-Mail

Figure 2 : Tables des données de la base de FRIEND AOC
 Figure 2 : FRIEND AOC data base tables.

4 Type d'éditons et d'inventaires.

Les éditions sont obtenues au moyen de critères tels que la nature des données, le pas de temps, les stations ou les postes etc. BADOIE permet aussi l'élaboration de graphiques afin de mieux visualiser les données.

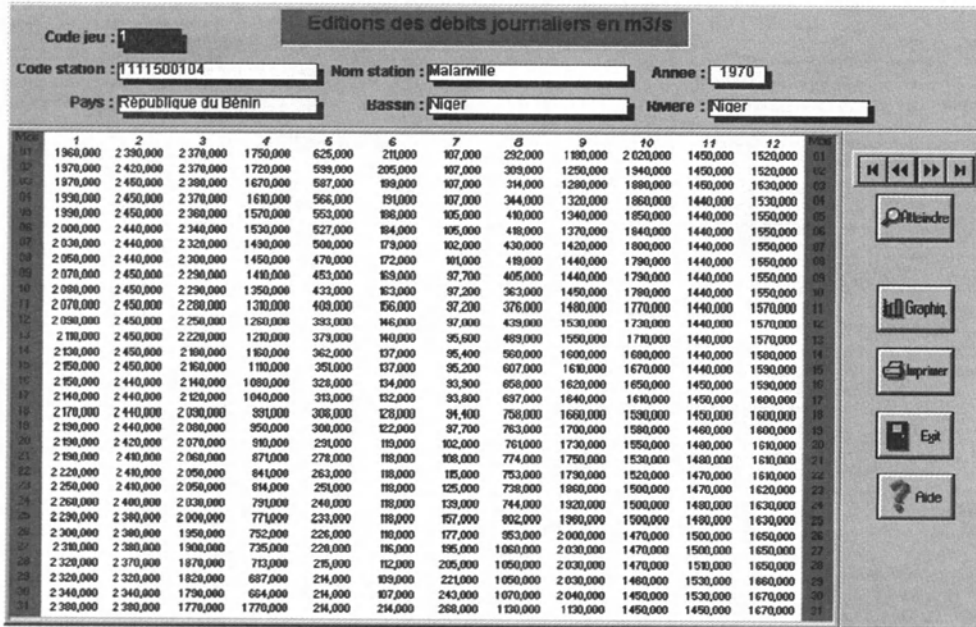

Figure 3 : Exemple d'édition des données fournie par BADOIE

Figure 3 : An example of data output from BADOIE.

Deux types d'inventaires coexistent au sein de BADOIE: (fig 4) les inventaires sous forme de tableaux (annuels, par périodes et mensuels) qui permettent de représenter la disponibilité et le taux de lacunes des données, et (fig 5) les inventaires sous forme de cartes qui permettent une meilleure visualisation, en matière de dispersion géographique, des données et des stations ou postes dont dispose la base. Les mêmes principes de représentation cartographique sont utilisés pour visualiser la qualité et la quantité des données (taux de lacunes et nombre).

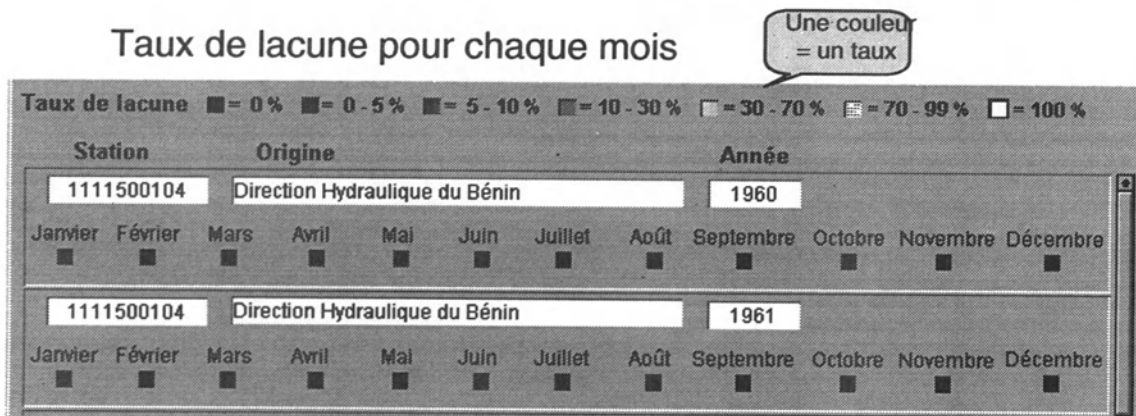

Figure 4 : Exemple d'inventaire annuel fourni par BADOIE

Figure 4 : An example of annual inventory from BADOIE

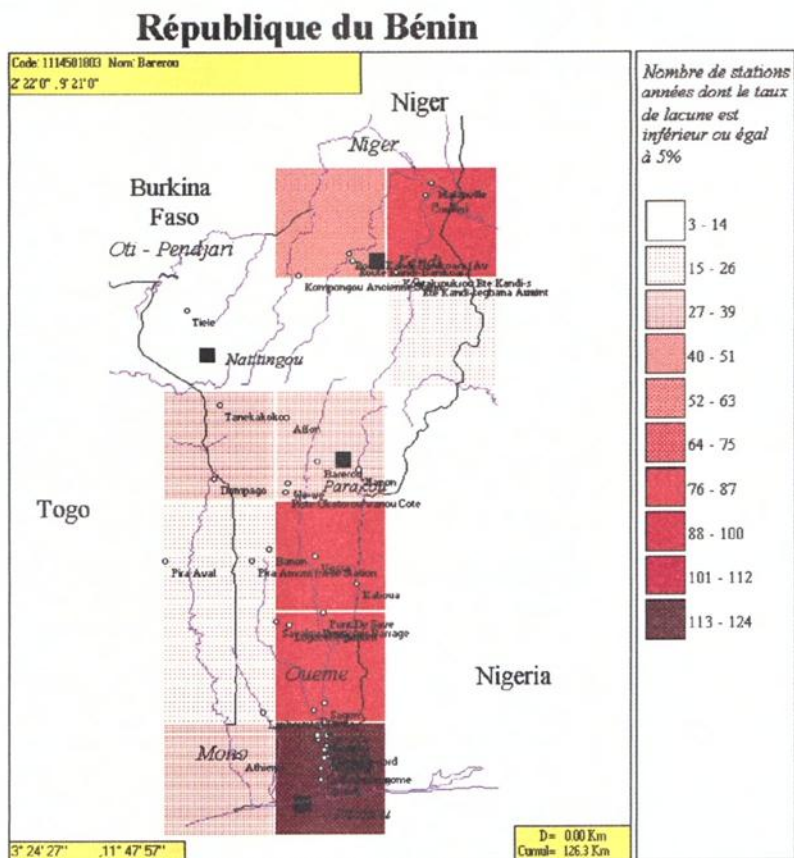

Figure 5 : Exemple d'inventaire sous forme de carte fourni par BADOIE
Figure 5 : An example of an inventory in map form from BADOIE.

5 Conclusion

BADOIE et son contenu constitue le noyau de ce que devrait être, à terme, la grande base de données sur l'Afrique de l'Ouest et Centrale. Les données contenues sont déjà nombreuses et ont été fournies par les différents partenaires du projet: pays et partenaires institutionnels ou scientifiques tels que l'ORSTOM. Ce logiciel et la base de données qu'il gère, devrait évoluer vers un produit plus ambitieux qui semble indispensable à la réalisation de projets importants dans le domaine de l'Hydrologie Régionale. Cette base sera réalisée dans les années à venir et constituera, à n'en pas douter, un outil de référence.

Etat de la base de données du projet FRIEND AOC

FRIEND AOC database inventory

J.F. Boyer, E. Servat, J.M. Fritsch

1 Introduction

Ce rapport présente l'inventaire des données disponibles dans la base de données du projet FRIEND AOC à la date du 1-07-1996. Ces données concernent l'ensemble des pays de la zone AOC et peuvent être classées en deux groupes: les informations environnementales, qui constituent les données proprement dites et qui sont référencées dans ce document et les informations de fonctionnement qui constituent les éléments nécessaires à la gestion dynamique des données (origine des données, modifications apportées au jeu original, etc.).

Les données environnementales référencées dans ce document sont des débits et des pluies ainsi que des informations concernant les stations hydrométriques et les postes pluviométriques auxquels elles sont rattachées.

2 Données

Chaque donnée est associée à une station hydrométrique ou à un poste pluviométrique et à une date. Un code descriptif associé fournit des informations précises quant à la nature de la donnée, à savoir si la valeur est originale, modifiée ou reconstituée avec, dans ce dernier cas, la méthode de calcul utilisée. Les unités utilisées dans cette base sont le m³/s pour les débits et le mm pour les pluies.

3 Contenu de la base du projet FRIEND AOC

La totalité des données mises à disposition du projet FRIEND AOC représente, pour quinze pays de la zone, 522 stations hydrométriques, 1120 postes pluviométriques, 13654 années de débit et 37417 années de pluie. Les stations hydrométriques et les postes pluviométriques retenus sont ceux pour lesquels il existe, au moins, une série historique de dix années de données. Il s'agit principalement de données au pas de temps journalier, et pour certains pays anglophones, de données de pluies mensuelles.

Les deux figures ci-dessous montrent la répartition géographique des données de la base. Pour chaque pays il est précisé deux chiffres: le premier représente le nombre d'années de données journalières ou mensuelles présentes, le deuxième, le nombre de stations ou de postes pluviométriques référencés.

La figure suivante donne pour chaque pays le nombre d'années de débits suivi du nombre de stations hydrométriques concernées.

4 Conclusion

Cette base de données compte, actuellement, parmi les plus complètes de la sous-région en matière de données hydro-pluviométriques. Pour les années à venir, un des objectifs dans le thème « Base de données » du projet FRIEND AOC consistera à étendre les données incluses dans la Base afin de prendre en compte de nouvelles variables. Il sera alors possible de fournir, aux utilisateurs, des données

environnementales complètes (végétation, sols, géologie, réseaux hydrographiques, topographie, etc.) permettant une meilleure approche des études hydrologiques à l'échelle régionale.

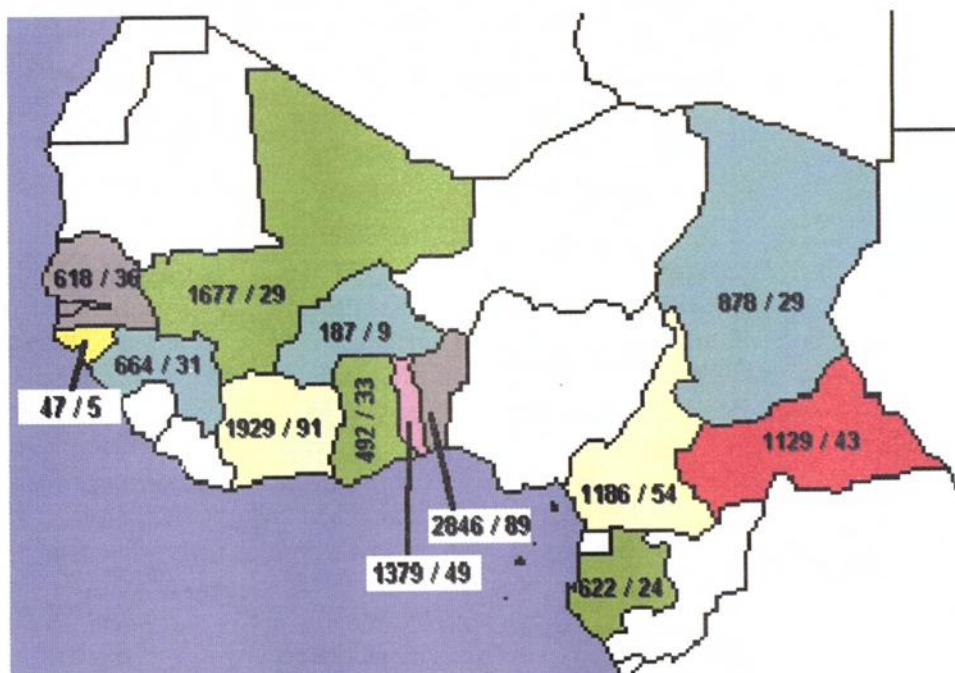

Figure 1 : Inventaire et répartition des données de débits
Figure 1 : Runoff data inventory.

La figure suivante donne pour chaque pays le nombre d'années de pluies suivi du nombre de postes pluviométriques concernés.

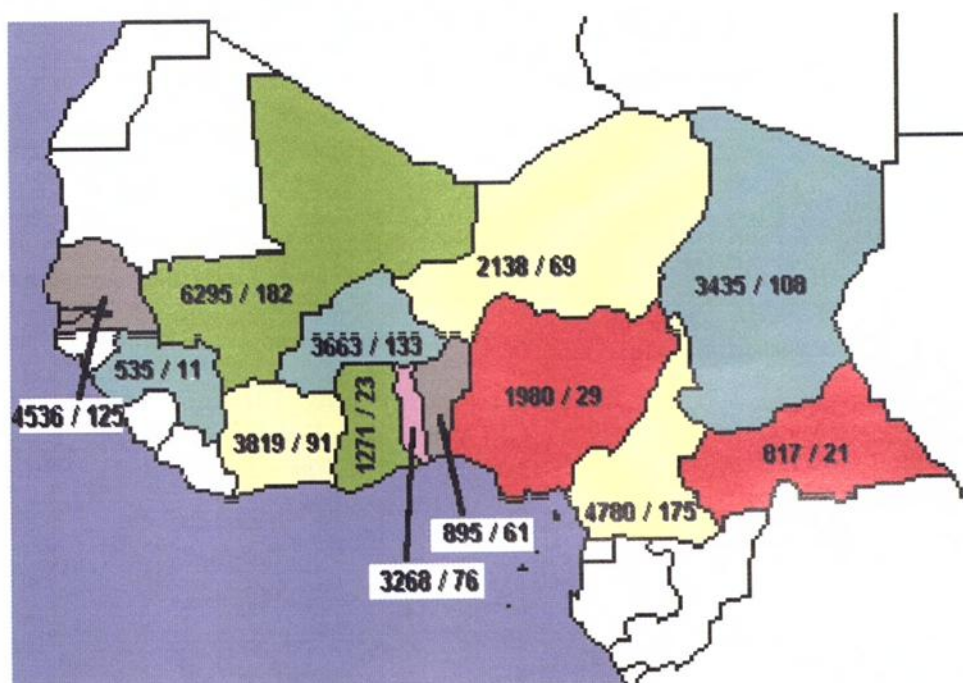

Figure 2 : Inventaire et répartition des données de pluies
Figure 2 : Rainfall data inventory.

GIS aspects of a FRIEND database

SIG et bases de données FRIEND

M. Brilly

1 Introduction

Hydrological cycles take place over a large span of space and time. Hydrological modelling is a simulation of a four dimensional natural process. Thus, multidimensional data manipulation is essential for hydrological modelling and the GIS (Geographical Information System) is a useful tool for these purposes. GIS is used to estimate parameters, to establish a model structure and to handle input and output data (Meijerink *et al.* 1994). The implementation of GIS has been much slower than expected (Kovar & Nachtnebel, 1993, 1996) due to complexity of commercial GIS software and with user training being very time consuming. The commercial GIS software have varying capabilities: some are excellent database managers (GEO/SQL), some are vector oriented (ARC/INFO, GEO/SQL etc.) and some are raster oriented (ILWIS, SPANS, Idrisi, GRASS). Acceptance and implementation of the SDTS (space data transfer standard) has been very slow, and in the meantime the exchange of data between GIS packages has not been possible without some difficulty and a lot of manual work. In fact, manipulating multidimensional data has been easier to do manually than by using GIS. The relationship between the hydrological model and the GIS develops in three stages (Figure 1).

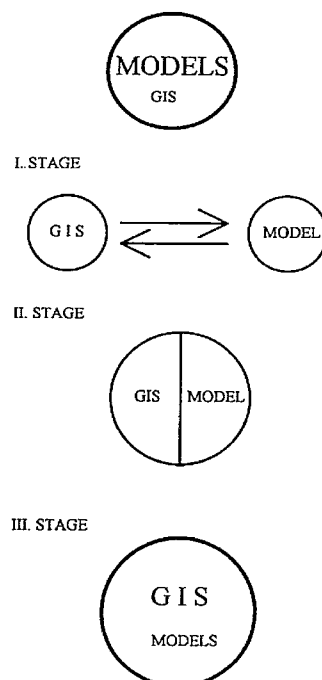

Stage I The GIS and hydrological models are separate and independent. The GIS is a tool used for data manipulation and estimation of parameters for the hydrological model. Various capabilities of the GIS programme related map modelling are used: overlay, calculation of geometrical parameters (stream length, stream slope, surface, surface slope, etc..) and mapping of output.

Stage II The GIS and hydrological models are joined in a common system and the models are connected by different data exchange formats (ASCII, SDTS, DXF etc.). The input data for the hydrological model is prepared using the GIS modelling component then the hydrological model is used for performing calculations and finally the output processed from the hydrological model using the GIS mapping component.

Stage III The GIS and hydrological models are incorporated into a single model with a common database. The GIS modelling capabilities are part of hydrological model.

Figure 1 : The relationship between the hydrological model and the GIS

Figure 1 : Les liens entre un modèle hydrologique et un SIG

There are many examples of the usefulness of GIS in hydrology (Seuna *et al.* 1993, Meijrink *et al.* 1994, Kovar & Nachtnebel, 1993 and 1996), many of which at Stage I of development. There a few examples at Stage II, including the GIS implementation for FRIEND.

Many years ago, research software reached Stage III of GIS implementation, simply by incorporating the GIS model routine into the hydrological model. Most raster oriented data in the FRIEND project is handled in this way. Some of this software has been developed into a commercial form (ILWIS). Today commercial software for hydrological modelling is in Stage II of development, with user friendly interfaces for data input and mapping (DODSON, BROSS etc. for HEC and USGS software etc).

The Stage III is related to providing programmer friendly commercial GIS software. The market for these products changes from day to day. The standards for data collection and storage, as well as the procedures and formats for data exchange are the most important areas for future development.

2 FRIEND database and GIS

The hydrological database incorporates a large amount of numerical discharge and rainfall data which requires a good database manager on a main frame computer. The FRIEND European Water Archive uses ORACLE software as the optimal solution related to hardware and software development. The development of a space related multidimensional database by GIS has been stressed as an important task for future development (Roald *et al.* 1994).

During assembly of the AMHY FRIEND database, much alpha-numeric data about stations has been collected (name, code, country, river, basin, theme, participant, institution etc.) The database now comprises two parts: the inventory database of station data with alpha numeric information, and the numerical part containing time series data from the hydrological stations. The handling of such a database and choice of database manager (object oriented or relational) were considered in the AMHY seminar in Thessaloniki (Manea *et al.*, 1996). It was concluded that an object oriented database manager is more useful for handling the FRIEND AMHY database.

Locations in the structure of the FRIEND AMHY database are indexed by the names of the station, river and region. Few data are related to the numeric geographical position, latitude and longitude, which could be handled by GIS or space database manager (SDBM). Positional data collected is longitude and latitude of the hydrological stations, the rectangle with maximum and minimum longitude and latitude of the watershed contour line and area of the watershed.

GIS tools have frequently been implemented for research and analysis of national FRIEND AMHY projects. Scientists have used the capability of a national GIS database with very good results in France, Spain, Italy and Slovenia. GIS is used in many countries for handling maps and data for hydrological modelling. Such investigations have not been fully reported in the FRIEND-AMHY reports. CEMAGREF use GIS as an analytical tool and for mapping of results in several ways depending on the project aims (Oberlin & Oancea, 1994). CEDEX have developed a national hydrological database HIDRO and SIMPA model (Integrated system for Precipitation - Runoff Modelling) in Spain (Quintas *et al.*, 1996 and Galea & Sourisseau, 1996). They use raster type GIS GRASS for calculations of water balance (precipitation, evapotranspiration and runoff) with a grid at a resolution of 1 km x 1 km. The results of the investigation are encouraging and GIS has proved to be very useful analysing and mapping spatial data. Different kinds of GIS software are used for different purposes in Slovenia (Kobold & Brilly, 1994, and Vidmar *et al.*, 1994), GEO/SQL software coupled with an ORACLE supported national water management database such as SDBM and SPANS handled data for low flows hydrological modelling, etc. It was found that there is no overall best software for all different purposes and sometimes it is advantageous to calculate some basin characteristics manually from maps.

The spatial database manager is a tool used to handle a spatially oriented database. However, a large GIS capability is not required for this purpose. There is a need to create a multidimensional

hydrological database with catchment boundaries, a DTM (digital terrain model) and a stream network. Ideas on how to manage a GIS inside the FRIEND databases are being considered within the AMHY project but no common practical solutions have yet been formulated.

The FRIEND databases will continue to develop into accessible global databases. The management, usage and further development of each database needs some common rules and common structures to make the database accessible to all regional FRIEND centres. Features which need to be addressed are the establishment of common standards for multidimensional data collection, digitising of watershed boundaries and the stream network, and definition of spatially oriented hydrological features for the FRIEND database.

3 Conclusions

- GIS is used widely for research at national levels and is a very useful tool for hydrological data handling and mapping of results.
- An important task for future work in the FRIEND project is the standardisation of national GIS data to enable ease of loading of space oriented hydrological data onto the FRIEND database.

Short Conclusion

Brève conclusion

H.G. Rees

Database management is a scientific discipline requiring a significant amount of specialist knowledge and technical expertise in its own right. The place of technology means there is almost a continual stream of new developments in the field, many of which have beneficial implications to hydrological databases in general and the FRIEND group databases in particular. The work of Manea in developing an object oriented database (OODBMS) for the AMHY group, described earlier in this chapter, illustrates how advances in database technology can be successfully applied in hydrology. While it is important for FRIEND groups to keep abreast of developments in new technology, it is vital that they are aware of related developments in other groups and other international hydrological and environmental programmes such as, for example, GRDC (Global Runoff Data Centre), GRID (Global Resource Information Database) and WHYCOS (World Hydrological Cycle Observation System). This report has provided an ideal opportunity to communicate the issues of FRIEND database management not only to FRIEND project participants but also to the hydrological research community at large.

An effective means of communicating project information is the Internet and, most notably, the World Wide Web (WWW). This new technology offers wide ranging facilities for publicising the science of the FRIEND project to a potentially massive audience. As Breil describes in his paper, information on the AMHY project is already available on the Web. Surely, it will not be long before other FRIEND groups follow this example of using the WWW to publicise their own research activities. Meanwhile, other Internet facilities, such as electronic mail (e-mail) and file transfer protocol (FTP), have had a significant impact on the operational aspects of managing FRIEND group databases. The ability to communicate between partners has vastly improved and, where data used to be unreliably transferred by mail on floppy disks or magnetic tape, large amounts of data are now able to be transferred almost instantaneously via this new medium.

This chapter has clearly demonstrated that FRIEND group databases are expertly managed and maintained. As has been seen, each of the FRIEND databases have evolved separately according to the infrastructure of the host organisation and the research requirements of the local FRIEND project. Despite this, there are several common features to consider. The first, which is a concern to all groups, relates to the quality of hydrological data. It is important, for regional analysis, that data from different countries are based on a system of measurements of equal reliability and precision. While database co-ordinators strive to eradicate errors from the data, the hydrometric quality of the data they receive is beyond their control. In an effort to overcome this, participants of the FRIEND project have been leading the calls for a conference on Quality, Management and Availability of Hydrological and Environmental Data. This initiative has been taken up by the IHP/OHP committees of Germany and the Netherlands and an international conference, to be held under the joint auspices of UNESCO and WMO, is planned at the end of 1998.

Another common issue is that of access to the FRIEND data. Database co-ordinators are very much aware of the need to safeguard the data they have been entrusted with. FRIEND data is normally supplied free of charge either, directly, by national hydrometric agencies or, indirectly, via project participants. The general rule still applies that data is given freely to participants of the FRIEND project on the strict condition that it is used only for FRIEND research.

While much of the early work of each FRIEND project has necessarily focussed on the collation of a time-series database of river flows, and, in some instances, precipitation, most projects are now seeking to augment this data with spatial (map referenced) data sets for analysis within Geographical Information Systems. Although the platform and the GIS software may vary between projects, the exchange of ideas and techniques can be of great value, especially for those who will face similar problems in future.

Above all, the FRIEND group databases described in this chapter illustrate that, with a degree of commitment and perseverance, political, cultural and technical barriers need not prevent the successful establishment of reliable international hydrological databases. The examples of the FRIEND databases in Southern Africa and in Western and Central Africa (AOC), in particular, demonstrate how much can be achieved despite very challenging circumstances. This should serve as a great incentive to the emerging FRIEND projects around the world and especially those of the Hindu Kush-Himalayan region, the Nile basin and South and Central America.

oooo

La gestion d'une base de donnée est une discipline scientifique requérant une somme significative de connaissance et d'expertise technique en la matière. La place des moyens technologiques dans ce domaine induit un flux presque continu de nouveaux développements, parmi lesquels nombre ont des implications bénéfiques, pour les bases de données hydrologiques en général, et pour celles des Groupes FRIEND en particulier. Le travail de Manea, de développement d'une base de données orientée objet (OODBMS) pour le groupe AMHY, exposé dans la première partie de ce chapitre, montre combien les avancées technologiques en matière de base de données peuvent être appliquées avec succès en hydrologie. Tandis qu'il est important pour les groupes FRIEND de mener de front les développements de nouvelle technologie, il est aussi vital qu'ils soient conscients des développements menés parallèlement dans d'autres groupes et programmes internationaux d'hydrologie et d'environnement, tels que, par exemple, GRDC (Global Runoff Data Center), GRID (Global Resource Information Database) et WHYCOS (World Hydrological Cycle Observation System). Ce rapport FRIEND a fourni une bonne opportunité pour communiquer les expériences et résultats de la gestion des bases de données FRIEND, non seulement aux participants du projet FRIEND, mais aussi à la communauté de recherche hydrologique au sens large.

Un autre moyen efficace de communiquer de l'information sur les projets est Internet, et plus particulièrement le Web (World Wide Web). Cette nouvelle technologie offre une vaste gamme de possibilités pour diffuser les aspects scientifiques du projet FRIEND avec une audience potentielle très large. Comme le décrit Breil dans sa contribution, des informations sur le Groupe AMHY sont déjà disponibles sur le Web. Il ne se passera sans doute guère de temps avant que d'autres Groupes FRIEND ne suivent cet exemple, exploitant le WWW pour afficher leurs propres activités de recherche. Pendant ce temps, d'autres possibilités offertes par Internet, telles que le courrier électronique (e-mail) et le transfert de fichiers FTP (File Transfer Protocol), ont eu un impact significatif sur les aspects opérationnels de la gestion des bases de données FRIEND. Cette capacité de communiquer entre partenaires a progressé et, là où les données étaient habituellement envoyées sans grande fiabilité par courrier, disquette, ou bande magnétique, une grande partie des données peut maintenant être transférée presque instantanément par ce nouveau moyen.

Ce chapitre a clairement démontré que les bases de données des Groupes FRIEND sont gérées et maintenues de façon experte. Comme cela peut être constaté, chacune des bases des Groupes FRIEND a évolué un peu indépendamment, selon la structure du laboratoire qui l'accueille et selon les besoins des recherches menées dans le Groupe. Cependant, il a plusieurs points communs à relever. Le premier, et qui concerne tous les Groupes, est lié à la qualité des données hydrologiques. Il est important, pour l'analyse régionale, que les données des différents pays soient basées sur un système de mesures de fiabilité et de précision équivalentes. Mais bien que les coordinateurs des bases de données s'efforcent d'éradiquer les erreurs dans les données, la qualité hydrométrique des données qu'ils reçoivent est hors

de leur contrôle. Dans un effort pour dépasser ce problème, des participants au projet FRIEND ont lancé un appel pour l'organisation d'une conférence sur la Qualité, la Gestion, et la Disponibilité des données hydrologiques et environnementales. Cette initiative a été prise en main par les comités PHI/PHO d'Allemagne et des Pays-Bas, et une conférence internationale, qui se tiendra sous le parrainage de l'UNESCO et de l'OMM, est prévue pour fin 1998.

Un autre point commun est celui de l'accès aux données FRIEND. Les coordinateurs des bases de données FRIEND sont très conscients de la nécessité de protéger les données qui leur ont été confiées. Les données FRIEND sont normalement fournies gratuitement, soit directement par les agences nationales hydrométriques, soit indirectement par les participants aux projets. La règle générale stipule que les données sont gratuitement mises à disposition des participants du projet FRIEND, mais à la stricte condition qu'elles soient utilisées uniquement pour des recherches entrant dans le cadre de FRIEND.

Alors que les tâches initiales ont été, dans chaque Groupe FRIEND, centrées sur le rassemblement de chroniques de débits et, dans quelques cas, de données de pluies, divers projets cherchent à présent à compléter ces données avec des caractéristiques spatiales via des SIG. Bien que ces outils SIG puissent varier d'un Groupe à l'autre, l'échange d'expériences et d'idées à ce sujet peut être d'un grand intérêt, tout particulièrement pour ceux qui aborderont cela ultérieurement.

Par dessus tout, les bases de données des Groupes FRIEND présentées dans ce chapitre illustrent que, sous réserve d'un engagement et d'une persévérance suffisants, les obstacles politiques, culturels et techniques ne peuvent s'opposer à l'implantation réussie de bases de données hydrologiques internationales fiables. Les expériences menées pour les bases de données FRIEND en Afrique australe, et en Afrique Occidentale et Centrale, ont par exemple clairement montré que beaucoup peut être fait, malgré des circonstances qui tenaient de la gageure. Cela devrait servir d'encouragement pour les nouveaux Groupes FRIEND émergents dans le monde, et tout particulièrement ceux des régions Hindu Kush-Himalaya, bassin du Nil, et Amérique du Sud et Centrale.

References of chapter 1

Références bibliographiques du chapitre 1

- Andrews A.J., Mwakalinga I. E. & Bullock, A. (in preparation) : Southern African FRIEND river flow data base. Chapter 2 in Bullock, A., *et al.* "Southern African FRIEND". Unesco.
- Andrews A.J. & Bullock A. (in preparation) : Southern African FRIEND spatial data base. Chapter 3 in Bullock A., *et al.* "Southern African FRIEND". Unesco.
- Beran M., Wiltshire S. & Gustard A. (1984) : Report of the European Flood Study. Institute of Hydrology, Wallingford, Oxfordshire, UK.
- Booch G. (1992) : Conception orientée objets et applications, Addison-Wesley Publishing Company Inc., 1992.
- Brunet J. (1993) : Analyse conceptuelle orientée objet, Thèse de doctorat de l'Université Paris VI, 1993.
- Cattell R.G.G. (1994) : The Object Database Standard : 93, Morgan Kaufmann Publishers, 1994
- Coad P. & Yourdon E. (1990) : Object Oriented Analysis, Yourdon Press Computing Series, Prentice Hall, 1990.
- Delobel C., Lécuse C. & Richard P. (1991) : Bases de Données : Des systèmes relationnels aux systèmes à objets, InterEditions, 1991.
- Delobel C., Bancilhon F., *et al* (1992) : Building an Object-Oriented Database System - The story of O2, Morgan Kaufmann Publishers, 1992.
- Desfray P. (1993) : Ingénierie des objets. Approche Classe - Relation. Application à C++, Masson, 1993.
- Fahrner C. & Vossen G. (1995) : A survey of database design transformations based on the Entity - Relationship model, *Data & Knowledge Engineering* 15, 1995, 213-250
- Gustard A. (ed.) (1993) : Flow Regimes from International Experimental and Network Data (FRIEND) - Volume I Hydrological studies. Institute of Hydrology, Wallingford, Oxfordshire, UK. pp.209.
- Keller A.M. & Turner P. (1994) : Migrating to Object Data Management, Stanford University, 1994
- Kobold M. & Brilly M. (1994) : Low flow discharge analysis in Slovenia, FRIEND, IAHS Publication 221, pp.119 - 131.
- Kovar K., & Nachtnebel H.P. (1996) : Application of Geographic Information Systems in Hydrology and Water Resources Management, IAHS Publication No. 235.
- Manea A., Breil P., & Desbos E. (1997): FRIEND-AMHY data base scheme, *Seminaire international annuel du Groupe AMHY de FRIEND, Thessalonique - 1995, Rapport annuel AMHY n°5, UNESCO*, pp. 29-35.
- Manea A., Lang A. (1994) : Breche project of hydrological database for ERB: modelling of data series, *Technische Universität Braunschweig/FRIEND Conference/11-15 October 1993 Germany, IAHS volume n°221*, pp.9-14
- Manea A., Givone P.(1995) : Hydrological Information System design ; requirements, specifications evolution *Intrnational Conference on Meteorological and Hydrological Technology and its Management Geneva 22 - 26 May 1995*, pp. 202-205
- Meijerink A.M.J., Brouwer H.A.M., Mannaerts C.M., & Valenzuela C.R. (1994) : Introduction of the use of Geographic Information Systems for practical Hydrology, UNESCO, ITC Publication Number 23, Enschede, Netherlands.
- Oberlin G., & Oancea V. (1994) : Hydrological regimes, *Seminaire international annuel du Groupe AMHY de FRIEND, Perugia 1992, Rapport annuel AMHY n°2, UNESCO, Paris*, pp. 113-136.
- Quintas L., Ardiles L., & Ferrer M. (1996): Analysis of the Spanish data from FRIEND-AMHY data base, *Seminarie international annuel du Groupe AMHY de FRIEND, Thessalonique - 1995, Rapport annuel AMHY n°5, UNESCO Paris*, pp. 44-55.
- Roald L.A., Wesselink A.J., Arnell N.W., Dixon J.M., Rees H.G., & Andrews A.J. (1994) : The FRIEND data base, FRIEND, IAHS Publication 221, pp.13 - 20.
- Rumbaugh J., Blaha M., Premerlani W., Eddy F. & Lornsen W. (1991) : Object Oriented Modeling and Design, Prentice-Hall International Editions 1991
- Seuna P., Gustard A., Arnell N.W., & Cole G.A. (1994) : FRIEND: Flow Regimes from International Experimental and Network Data, IAHS Publication No. 211.
- Shlaer S. & Mellor S. J (1988) : Object Oriented Systems Analysis : Modeling the World in data, Prentice Hall, 1988
- Vidmar A., Brilly M, & Smith M. (1994) : River Basin Coding, *Geo/SQL in Water Resource Management, Seminaire international annuel du Groupe AMHY de FRIEND, Perugia 1992, Rapport annuel AMHY n°2, UNESCO, Paris*, pp. 48-54.

Chapter 2

Regimes and regional hydrology

Short introduction

N. Arnell

Regional hydrology is concerned with describing and understanding hydrological regimes and variability over regional and continental scales. The FRIEND project provides an ideal opportunity for research into hydrology over a large geographic domain. There are three main reasons for undertaking hydrological research at scales considerably larger than that of the catchment :

1. to better understand water budgets and fluxes, at continental scales;
2. to better understand the nature of hydrological variability;
3. to better predict - over space, and perhaps time - hydrological behaviour.

Regional analysis, particularly investigating patterns of variability and macro-scale water fluxes, is a major growth area in hydrology.

This chapter describes a number of research areas within the theme of regional hydrology, carried out in the FRIEND project. Figure 1, prepared for the North West European FRIEND, attempts to summarise the main areas of research and their interlinkages. This chapter describes work under most of the areas indicated - although not all FRIEND work is represented in the chapter. The first three papers come from the European FRIEND projects.

Arnell & Shorthouse summarise research into spatial patterns in variability in European hydrological behaviour, showing a strong, and regionally variable, correlation with a measure of climatic variability.

Stanescu & Ungureanu build upon work described in the 1993 FRIEND report and elsewhere to characterise runoff regime types in central and southern Europe.

Krasovskaia & Gottschalk extend their work on runoff regimes, by focusing on the stability of regime types from year to year, and how stability is a characteristic of regime type.

The next three papers describe research undertaken in the African FRIEND projects.

Servat *et al* focus on tropical regimes and climatic trends in west and central Africa. They show a decline in runoff in the last 25 years, with a break in many study catchments between 1968 and 1972. Runoff is reduced by up to 60%, particularly in the southern Sahel.

Mahé *et al* explore hydrological regionalisation in west and central Africa, at two scales. Their analysis confirms the general reduction in runoff in the region since the early 1970s, and shows that rates of recession in the upper Niger basin have also been high since then.

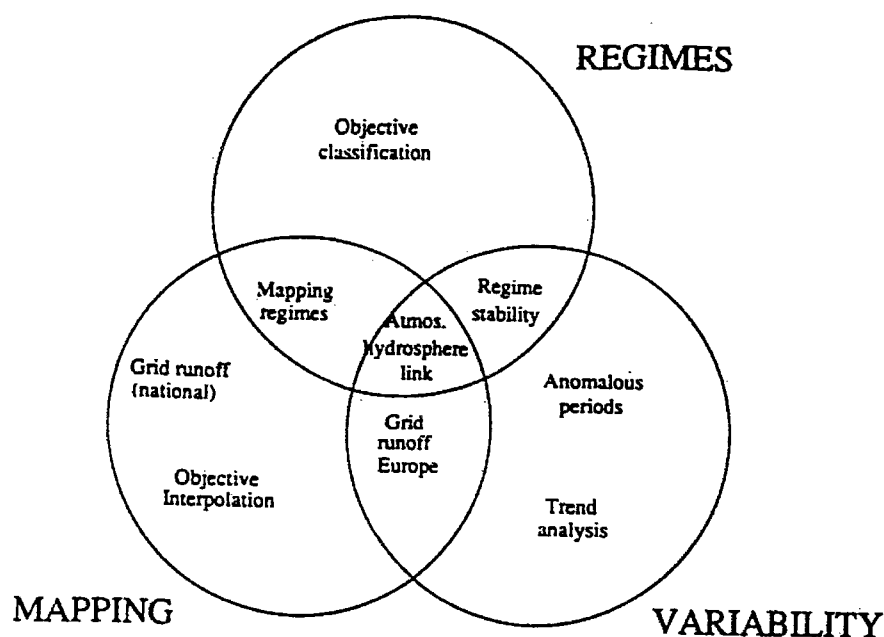

Figure 1 : FRIEND research into large-scale hydrology

Figure 1 : Les recherches, dans FRIEND, sur l'hydrologie des grandes mailles

Laraque & Orange describe a study into variations in flows in major rivers in the Congo Zaire catchment. Preliminary results show lower runoff in the Oubangui from the early 1970s, but persistently below average flows in the Zaire itself only since the early 1980s.

The last papers in the chapter take a more generic approach to regional hydrology, illustrating some regional hydrological analysis methods with examples from Europe, and prepared inside the european FRIEND Groups (NEF and AMHY).

Galea & Prudhomme describe a method for transferring information on hydrological variability from gauged to ungauged catchments across a region. In essence, the method creates dimensionless depth-duration-frequency relationships for "typical" catchments, and applies them to other sites through local rescaling.

Leblois & Sauquet present results from an investigation into techniques for mapping runoff in south east France. Their method interpolates statistically between catchments, accounting for variations in catchment size.

Finally, **van der Wateren-de Hoog** shows that the sensitivity of a catchment to climatic variability is, for a given climate, dependent on catchment storage properties. Through a regional model applied in the Loire and Neckar basins, she demonstrates that catchments with low storage are most sensitive to climatic variability.

These papers give a flavour of the research into large-scale regional hydrology undertaken as part of the FRIEND project. Aspects of the work relate closely to the spatial studies of drought described in Chapter 3, and research also relates to the long time series analyses described in Chapter 7.

Brève introduction

N. Arnell

L'hydrologie régionale concerne la description et la connaissance des régimes et de leur variabilité hydrologique, à des échelles régionale et continentale. Le projet FRIEND offre une bonne opportunité pour la recherche hydrologique à grande échelle, et il y a de bonnes raisons pour faire de la recherche à une échelle plus grande que celle d'un bassin :

1. pour mieux comprendre les bilans de l'eau, et les flux à l'échelle continentale;
2. pour mieux comprendre les caractéristiques de la variabilité hydrologique;
3. pour prévoir - dans l'espace et, peut-être, dans le temps - les caractéristiques des régimes hydrologiques.

Depuis quelques années, l'analyse régionale, en particulier celle étudiant la variabilité spatiale et les flux à l'échelle continentale, est devenue très importante.

Ce chapitre présente quelques sujets de recherche sur le thème de l'hydrologie régionale, préparés dans le cadre du projet FRIEND. La figure 1, réalisée dans le cadre du Groupe NEF de FRIEND, montre les champs de recherche et leurs relations. Ce chapitre décrit des recherches sur la plupart de ces champs, mais toute la recherche menée dans FRIEND n'y est pas incluse. Les trois premiers articles ont été traités dans les Groupes FRIEND européens.

Arnell et Shorthouse résument des recherches menées sur les caractéristiques spatiales de la variabilité hydrologique en Europe. Ils montrent un rapport fort entre la variabilité hydrologique et un indice de circulation atmosphérique.

Stanescu et Unguraneau étendent une recherche initiée dans le rapport FRIEND de 1993, et caractérisent les régimes hydrologiques en Europe du sud et centrale.

Krasovskaia et Gottschalk développent leurs études des régimes hydrologiques. Ils se concentrent sur la stabilité des régimes d'année en année, et montrent que la stabilité est une caractéristique d'un type de régime.

Les trois articles suivants décrivent des recherches menées dans les Groupes africains de FRIEND.

Servat et al se concentrent sur des régimes tropicaux et sur les tendances climatiques en Afrique de l'ouest et centrale. Ils montrent qu'il y a un déclin des débits depuis 25 ans, avec une rupture entre 1968 et 1972. La réduction de l'écoulement dans le sud du Sahel va jusqu'à 60%.

Mahé et al explorent la régionalisation hydrologique en Afrique de l'ouest et centrale, à deux échelles. Leurs analyses confirment le déclin de débits depuis 1970. La tarissement des débits dans le haut bassin du Niger est aussi plus rapide depuis 1970.

Laraque et Orange décrivent une étude des variations des débits dans les grands fleuves du bassin du Zaïre. Les résultats préliminaires montrent que l'écoulement dans le bassin de l'Oubangui a diminué depuis 1970, mais que les débits sont plus bas que la moyenne seulement depuis 1980.

Les articles suivants présentent une approche plus générale. Ils développent des méthodes régionales, et illustrent leurs applications avec des données européennes. Ils ont également été préparés dans le cadre des Groupes FRIEND européens (AMHY et NEF).

Galéa et Prudhomme décrivent une méthode pour le transfert des données hydrologiques des bassins jaugés aux bassins non-jaugés, dans la même région. La méthode crée des courbes débit-durée-

fréquence adimensionnelles sur des bassins de référence, et applique ces courbes à des bassins différents, après estimation de coefficients locaux.

Leblois et Sauquet présentent les résultats d'une étude méthodologique pour faire des cartes d'écoulements. Ils développent une méthode stochastique pour l'interpolation entre les bassins, qui inclut les effets des variations de l'échelle spatiale de bassin.

Finalement, **van der Wateren-de Hoog** démontre que la sensibilité d'un bassin à la variabilité du climat dépend, pour un climat donné, des caractéristiques de stockage du bassin. Il utilise un modèle régional, appliqué sur la Loire et le Neckar, et démontre que les bassins avec des stockages petits sont les plus sensibles à la variabilité du climat.

Les articles de ce chapitre donnent une idée des recherches à grande échelle faites dans le projet FRIEND. Les études ont un rapport étroit avec les investigations sur la structure spatiale des sécheresses (chapitre 3), et sur la recherche dans les analyses de séries longues (chapitre 7).

European hydroclimatology : the continental scale

Hydroclimatologie en Europe : l'échelle continentale

N. Arnell and C. Shorthouse

Introduction

Droughts and floods in Europe in the last few years have emphasised the strong degree of spatial coherence in hydrological response to climatic anomalies (Arnell, 1994). Large parts of Europe show similar patterns of variability, whilst others show - consistently - opposing patterns. A research project is therefore underway to (i), describe spatial patterns of anomalous hydrological behaviour in Europe, and (ii), interpret these patterns in terms of climatic anomalies. A long term benefit of the research *may* be improved prospects for seasonal flow prediction.

The broad pattern of European climate is dominated by the westerly movement of depressions. The position, and strength, of these westerlies is influenced by the relative positions and strengths of the Icelandic Low and the Azores High, quasi-stable features in the North Atlantic. Sea surface temperatures also affect storm track position, and these are influenced by both variations in the strength of the Gulf Stream and by winds in the North Atlantic. During winter, the penetration of westerlies into continental Europe is restricted by the Siberian High pressure zone, and continental Europe experiences cold, stable conditions during winter. During summer, pressure over the continent is lower, but the westerlies are weaker so cannot penetrate far inland. Occasionally, an independent anticyclonic cell will form, usually between Scandinavia and the Faroes, blocking the passage of depressions across western Europe. Depressions are therefore forced to the north - and sometimes further to the south - bringing anomalous precipitation and temperatures lasting up to several weeks.

These general features vary in characteristics from year to year, and these variations lead to inter-annual variations in hydrological behaviour with a strong, macro-scale, spatial coherence. One general measure of European climate is the North Atlantic Oscillation Index (NAOI), which describes the difference in pressure between the Azores High and Icelandic Low. When the index is high - and the pressure difference is greatest - westerly circulation is more intense, allowing depressions to penetrate further and bringing above average precipitation to northern Europe, whilst leading to lower precipitation in central and southern Europe (Hurrell, 1995). The NAOI does not vary randomly from year to year, but exhibits some persistent patterns. Figure 1 shows the NAOI for winter (December to February): during the 1980s, most years have had a high index, and stronger circulation.

In other parts of the world, strong teleconnections have been found between climatic variability in the south Pacific - characterised by the El Nino/Southern Oscillation (ENSO) - and hydrological anomalies. Waylen & Caviedes (1990), for example, showed considerable differences in flood frequencies in Chile in high ENSO years as compared with normal conditions, and Dracup & Kahya (1994) described the different flow regimes in the Pacific North West of the United States in different parts of the ENSO cycle. There are many other examples. However, the ENSO signal in Europe is weak - although Fraedrich & Müller (1994) showed anomalous winter precipitation patterns following high ENSO events - and may be difficult to separate from the North Atlantic Oscillation.

This paper describes some preliminary results from an analysis of regional hydrological data in Europe, focusing particularly on associations between the NAOI and regional hydrological anomalies.

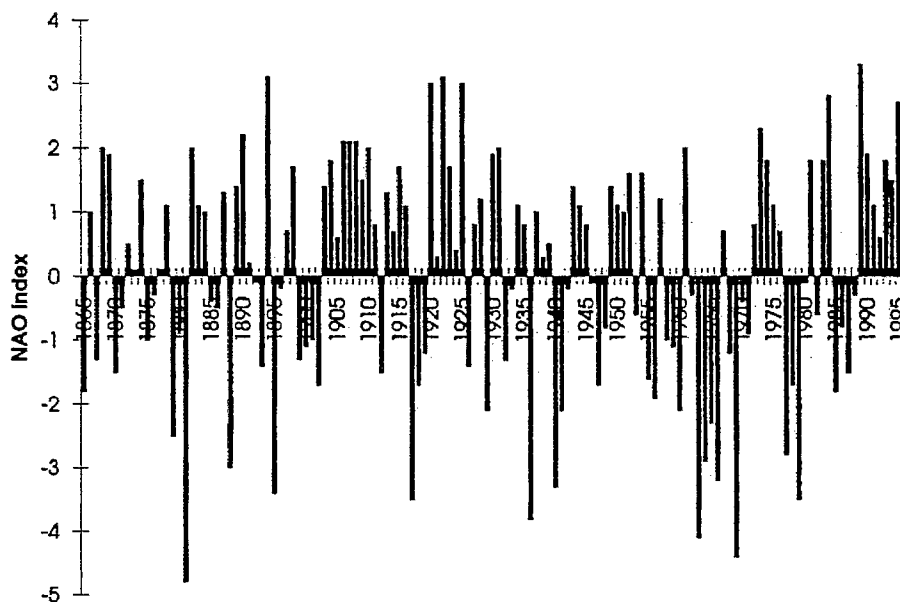

Figure 1 : Interannual variability in the North Atlantic Oscillation Index : winter
Figure 1 : Variabilité interannuelle de l'Oscillation Atlantique Nord : hiver

Methods and data

The study uses monthly data from the FRIEND European Water Archive. Initially, only catchments with an area less than 750km² and with 30 years of data spanning the period 1961 to 1990 were considered, giving a total of 477 catchments. However, these catchments were strongly clustered in space, leaving some significant gaps. The second rule was therefore relaxed in some areas, to include catchments with at least 20 years between 1961 and 1990. This increased the number of catchments included to 744.

The analysis described here uses regional average hydrological time series, calculated for each FRIEND hydrometric area. The 744 catchments fell into 238 hydrometric areas. For each area, a regional index was calculated in two stages. First, the catchment time series (at monthly and seasonal time steps) were standardised by subtracting the monthly or seasonal mean and dividing by the standard deviation of the monthly or seasonal flows. Second, the regional index was determined for each month or season by averaging the catchment standardised indices.

Some preliminary results

Simple anomaly maps (such as Figure 2) illustrate the strong degree of spatial coherence in European flows. In the example shown - January 1975 - flows are above average across much of northern, western and central Europe, but are below average in the south. Figure 3 shows the correlation between January runoff and the January NAOI, illustrating two points. First, correlations across much of Europe are very strong, and second, a high NAOI (i.e. vigorous depressions) is

associated with above average runoff in parts of northern and central Europe, and below average runoff in southern Europe.

Conclusions : ongoing research

This paper has presented some preliminary results from ongoing research. These results have shown the strong correlations between climatic anomaly - as indexed by the North Atlantic Oscillation Index - and hydrological anomaly, with strong spatial patterns. Current research is aimed at exploring these relationships further (looking for example at lags in correlations), and at investigating possible relationships in other seasons. Also, other indices of climatic variability will be examined, including the ENSO index, the position of the Gulf Stream, sea surface temperature anomalies and the position of the jetstream. The effect of climatic variability on hydrological response will depend on the regime and physical characteristics of the catchment, and these effects too are being investigated.

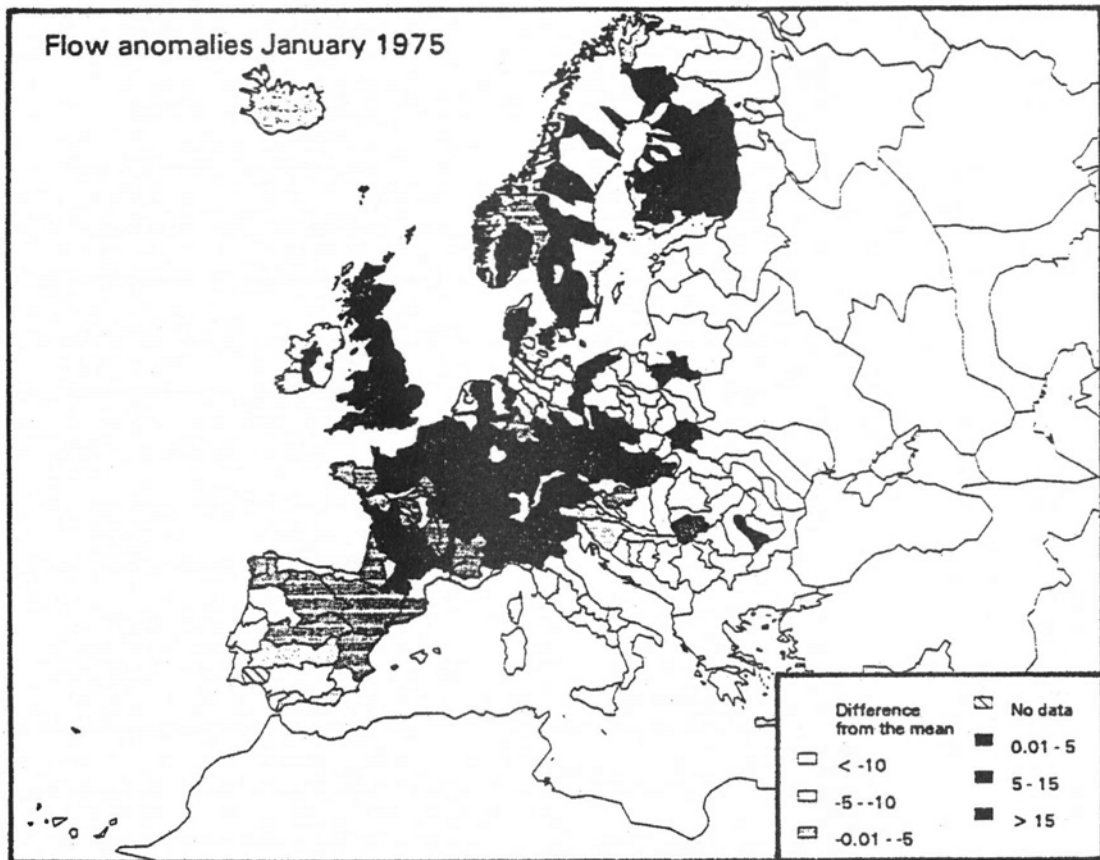

Figure 2 : Hydrological anomaly: January 1975
Figure 2 : Anomalie hydrologique : janvier 1975

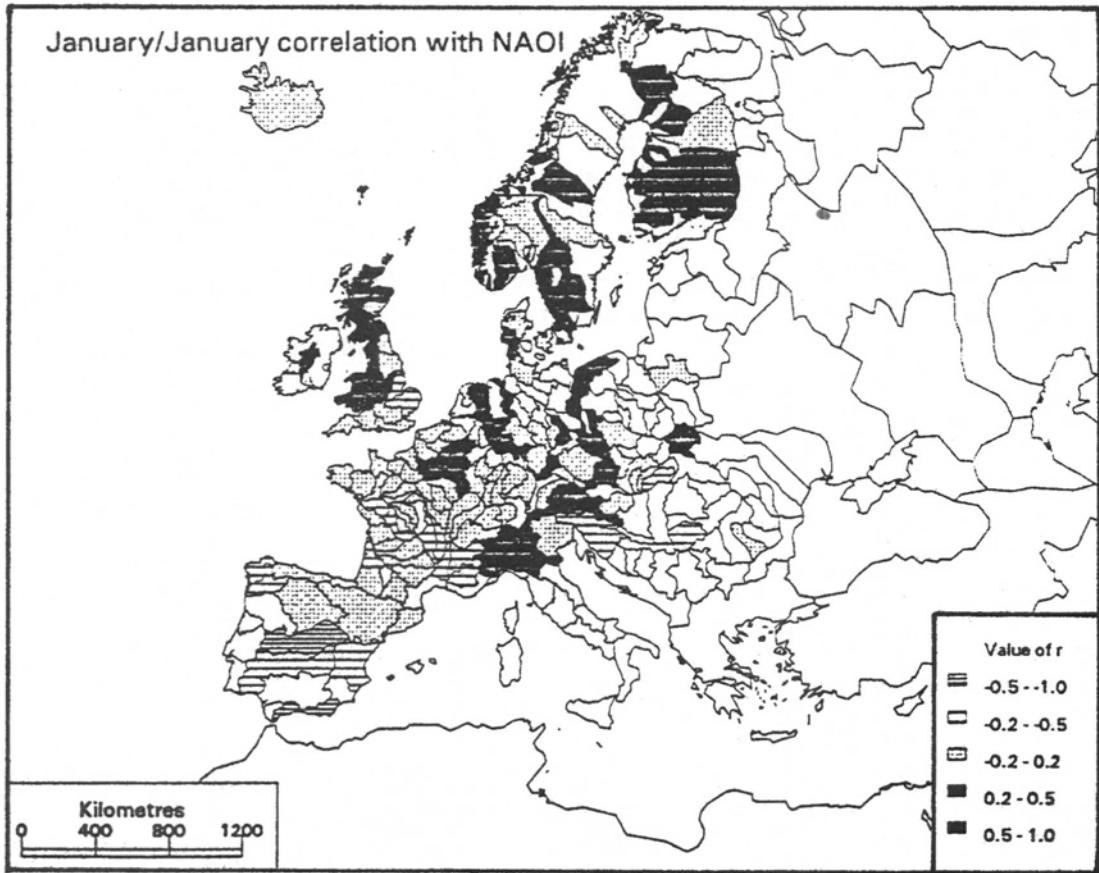

Figure 3 : Correlation between January NAOI and January runoff
Figure 3 : Liaison entre l'indice OAN et l'écoulement, en janvier

European regimes : diversity and features

Régimes Européens : diversités et caractéristiques

V. Al. Stanescu, V. Ungureanu

1 Introduction

A river flow regime type is defined by the variation of the flow throughout the year as the *timing* of the maximum and minimum flow seasons and range in the discharges during each flow phase dependent on its origin and the basin peculiarities.

In the report on “European River Flow Regimes” (Arnell *et al.*, 1993) nine types of regimes, adapted from Gottschalk *et al.*, (1979) and Krasovskaia and Gottschalk (1992), have been established in Europe. The regime types refer to the widely-distributed areas where they are found, the periods of the year when the high and low flows occur, and the type of water supply (rainfall and/or snowmelt). The river flow regimes presented in this work refer to a broadest, European scale and they are dependent on the main climate features. At a finer scale, the effects of a particular climate on the river flow regimes are considerably controlled by the physiographical properties of the catchment. Among these, the altitude plays the most important role as it expresses on the one hand the gradual variation on the vertical of a particular macro-type of the climate and it implicitly reflects the configuration of the hydrographical network, channel and slope gradients, soil and land cover. Thus the diversity and the features of the regimes are connected with the time and space scale at which the hydrological analysis is made.

The present work describes the regime types at a finer scale, concentrating on (i) means of representation of the flow regimes, (ii) types of the regimes defined by the timing of the high and low flow phases, (iii) regionalisation of some “micro-types” in some countries from the FRIEND-AMHY area, and (iv) stability of the river flow regimes.

2 Means of representation of the river flow regimes

The following types of hydrographs may offer an image of a river flow regime :

- Typical hydrograph which is drawn on the basis of the most frequent phases of the flow expressed in terms of the timing (earliest, mean, latest) as well as by the characteristic values of their daily discharges (Stanescu, 1967). In Figure 1 a typical hydrograph of a river of Romania is presented (Diaconu *et al.*, 1994). The typical hydrograph may be relevant for the schematic representation of the river flow regime provided that the occurrence of the phases does not vary too much in time. That fact assumed a relatively high stability of the occurrence of the characteristic phases of the flow as well as a high degree of the natural regulation of the flow. Hence, the use of such a representation is generally applicable for the catchments of medium and large areas.
- Daily flow hydrograph in the characteristic (wet, dry and average) years. An example of such a hydrograph in the average year (50% probability) for a river of Romania is presented in Figure 2.
- Mean monthly flow hydrograph which significantly represents the seasonal flow regime but due to the averaging of the monthly flows in individual years cannot reflect the occurrence of the characteristic phases of the daily flows. Nevertheless, taking into account that only the data on the mean monthly flows have been available, such monthly-based representation has been used in establishing at the finer scale the river flow regimes of the considered countries from the FRIEND-AMHY area. These countries are : Romania, Yugoslavia, Greece, Switzerland and Spain.

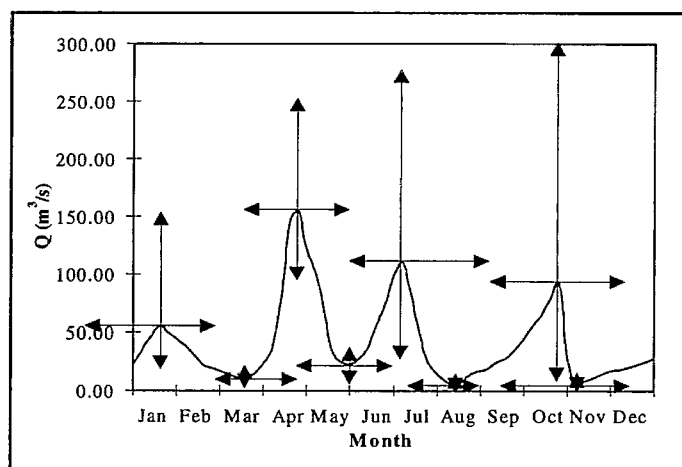

Figure 1 : Typical hydrograph

Figure 1 : Hydrogramme représentatif

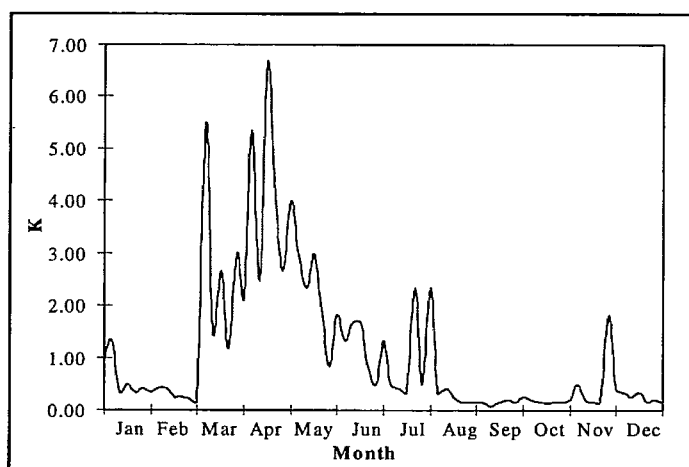

Figure 2 : Hydrograph in the average year (50% probability)

K - ratio of the daily flow against the mean annual discharge

Figure 2 : Hydrogramme d'année médiane

K - rapport du débit journalier (médian) au module

3 Periods of high and low flows

For the analysis the data from FRIEND-AMHY data base were used as well as the data published in the yearbooks of Romania and Yugoslavia as well as the data kindly provided by the national coordinators for the topic III-AMHY from Spain, Switzerland and Greece (Table 1).

Table 1 : Data used in the considered countries from FRIEND-AMHY area

Table 1 : Données exploitées des pays de la zone FRIEND-AMHY traités

Country	Number of stations	Period (years)
Romania	350	45 - 65
Spain	18	35 - 80
Yugoslavia	61	15 - 45
Greece	2	18 - 24
Switzerland	12	61 - 80

The classification of the hydrological regimes was done by the assessment of the *discriminating periods* defined by the first, the second and the third highest and lowest monthly flows, noted with MAX1, MAX2, MAX3, MIN1, MIN2, MIN3 respectively.

The river flow regimes at a finer scale in the FRIEND-AMHY area are influenced by : (i) the Mediterranean circulation, (ii) the oceanic circulation and (iii) the pronounced variation in altitude of the catchments. As an indicator of the development in elevation of the catchment, the mean altitude (\bar{H}) has been considered. Mention should be made about the relationship between the space (ranges in altitude) and time (monthly flow) scale considered in the analysis. In Figure 3 the mean monthly flows for three subbasins of different mean altitudes, embedded in a same catchment controlled by a particular climate are presented. For the subbasin of Arges Superior of a high altitude, at the Tunel station ($\bar{H} = 1442m$) the MAX1 value occurs in May followed by MAX2 in June. This timing is due to the late snowmelt combined with the abundant rainfalls caused in the period April-June by q Mediterranean circulation, more intense over this span of time. For the Argesel basin of a medium altitude ($\bar{H} = 668m$) at the Mioveni station, the flows MAX1 and MAX2, practically equal, occurs in the April and May. This “shifting back” from June-May to May-April is explained by the earlier snowmelt due to the lower altitude. For the Vedea basin of a low altitude ($\bar{H} = 176m$) the snowmelt is ended in early spring which results in the occurrence of MAX1 in March and of MAX2 even in February. Thus, an elevation range of about 500÷700 m (space scale) is sensitive to one month (time scale) shifting.

The shifting of the low flows MIN1 and MIN2 of the subbasins situated at low altitude from August-September towards December -February for those of a high altitude is explained by the occurrence of the long-lasting very low temperatures in the mountain zones.

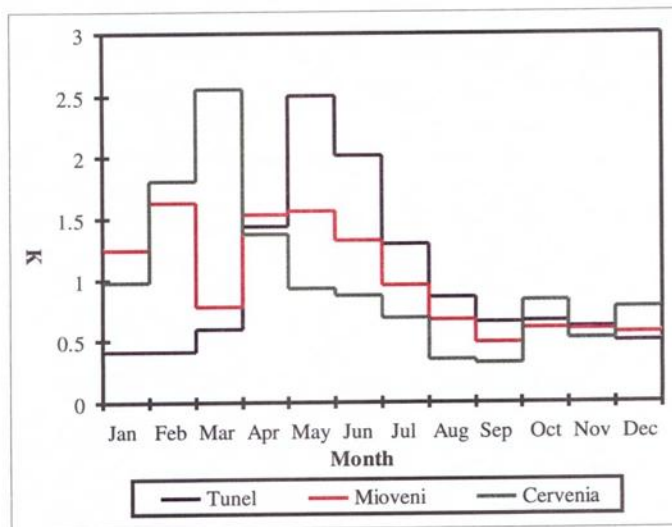

Figure 3 : Mean monthly flows for three subbasins of different mean altitudes
K - ratio of the mean monthly flow against the mean annual discharge

Figure 3 : Débits mensuels moyens pour trois bassins d'altitude moyenne différente
K - rapport du débit mensuel moyen au module

Thus, under a given climate influence, the situation of the catchments of different altitudes result in a diversification of the flow regime types with particular features.

4 Types of the river flow regime and their regionalisation

Relying upon the available data at the stations considered in Romania, Spain, Yugoslavia, Greece and Switzerland, the discriminating periods which define a particular river flow regime have been

Table 2 : River flow regimes and discriminating periods for the considered countries from FRIEND-AMHY area**Table 2 : Régimes d'écoulement des rivières, et sélection des saisons, pour les pays traités de la zone FRIEND-AMHY**

Country	Zone	Regime type	MAX1	MAX2	MAX3	MIN1	MIN2	MIN3
Romania	1	South-plain. Rainfall (snowmelt) origin	II-III	II-IV	II-IV	VIII-X	VIII-X	VIII-X
	2	Western and south-western. Rainfall-snowmelt origin	II-IV	II-IV	II-IV	IX-XI	VIII-X	VIII-X
	3	Central plateau. Rainfall-snowmelt origin	III-IV	III-IV	III-VI	IX-XI	VIII-XI	VIII-XI
	4	Eastern plateau. Rainfall (snowmelt) origin	III-IV	III-V	III-V	VIII-X	VIII-X	VIII-X
	5	Southern and eastern Carpatian. Rainfall-snowmelt origin	IV-VI	IV-VII	IV-VII	XII-II	XI-II	XI-II
	6	South-eastern Black Sea side. Rainfall origin	II-VI	II-VII	II-VII	IX-XI	IX-XII	IX-XII
Spain	1	Western and south-western zone. Oceanic circulation influence	XII-III	XII-III	XII-IV	VIII-IX	VIII-IX	VII-IX
	2	Central zone. Transition from oceanic to Mediterranean circulation	I-V (IV)	I-V	I-VI	VIII-IX	VII-IX	VII-X
	3	Eastern and south-eastern zone. Mediterranean circulation influence	II-V	II-VI	II-VI	VI-VIII	VII-IX	VII-IX
Yugoslavia	1	North plain - low altitude. Rainfall (snowmelt) origin	II-III	II-IV	II-V	VIII-X	VIII-X	VIII-X
	2	South-eastern zone - Juzna Morava. Rainfall-snowmelt origin	III-IV	II-IV	II-V	VIII-IX	VIII-X	VIII-X
	3	Eastern zone. Rainfall-snowmelt origin	III-IV	II-IV	II-V	VIII-IX	VIII-IX	VIII-X
	4	South-western zone. Rainfall-snowmelt origin	IV-V	IV-V	III-V	VIII-IX	VIII-IX	VIII-X
	5	Central zone - Žapadna Morava. Rainfall-snowmelt origin	III-IV	III-V	III-V	VIII-IX	VIII-X	IX-X
	6	Southern zone - high altitude. Rainfall-snowmelt origin	IV-V	IV-V	III-V	VIII-IX	IX-X	VIII-X
Greece	1	Northern high altitude - temperate influence). Rainfall-snowmelt origin	II-V	III-VI	III-VI	VIII-IX	VII-IX	VII-X
	2	Central zone - Mediterranean influence. Rainfall origin	XII-II	II-IV	III-IV	VIII-IX	VII-IX	VII-X
Switzerland	1	Glaciare A (66% glaciers)	VII-VIII	VII-VIII	VI-IX	I-II	I-II	I-II
	2	Glaciare B (33% glaciers)	VI-VIII	VI-VIII	V-VIII	I-II	I-II	XII-III
	3	Glacio-snowmelt A (17% glaciers)	VI-VII	VI-VIII	V-VIII	I-II	XII-II	XII-II
	4	Glacio-snowmelt B (7% glaciers)	VI-VII	VI-VIII	V-IX	XII-III	XII-III	I-III
	5	Snowmelt Glaciare	VI-VII	V-VII	V-VIII	I-III	I-III	I-III
	6	Snowmelt alpine	V-VI	V-VII	IV-VIII	I-II	I-II	XII-II
	7	Snowmelt of transition	IV-VII	IV-VIII	IV-VIII	I-II	XII-II	XII-III
	8	Snowmelt-rainfall subalpine	IV-VII	IV-VII	III-VII	I-II	XI-II	XII-II
	9	Rainfall origin (inferior and superior)	XII-III	XII-IV	XII-IV	VII-IX	VII-X	VII-X
	10	Jura rainfall origin	XII-III	XII-IV	XII-IV	VII-X	VII-X	VII-XI
	11	Jura snowmelt-rainfall origin	I-IV	XII-IV	XII-IV	VIII-X	VII-X	VII-X
	12	Southern snowmelt origin	VI-VII	V-VII	V-VIII	I-III	I-III	XII-III

determined (Table 2). The existence of different zones which are quasi-homogeneous from the physiographical properties stand point, expressed by their mean altitudes, allows to carry out a hydrological regionalization. In Figure 4 the mapping of the river flow regime zones for Romania (a) and Yugoslavia (b) is presented. The mean monthly flows defining several regime types in Spain, Greece and Switzerland are shown in Figure 5.

5 Stability of the river flow regimes

The stability of a certain flow regime may be quantitatively expressed by the sum of the entropies of the occurrence of the regime characteristics (maximum MAX1, MAX2, MAX3 and minimum MIN1, MIN2, MIN3 values) in the discriminating periods (Shannon and Weaver, 1941), (Krasovskaia, 1995).

The occurrence of a certain pattern of flow out of n types during individual years in a series is considered as an event E_i , the probability of which is $p_i = p(E_i)$ and $\sum_1^n p_i = 1$. The entropy H of the occurrence of each characteristics is given by :

$$H = -\sum_1^n p_i \times \ln(p_i) \quad (1)$$

The entropy has the maximum value when $p_1 = p_2 = \dots = p_n$ (complete incertitude or instability of the regime) and minimum value when $\forall p_i = 1$ (complete certitude or stability). Using property of additivity of the entropy the sum of the entropies of each characteristics (total entropy) expresses the entropy of the flow pattern and therefore the degree of its stability. In equation (1) consider the values p_i of the percentage of years in the series having a certain regime type, and compute for each p_i the total entropy. In terms of this total the degree of stability of the flow pattern (river flow regime) is established (Table 3).

Table 3 : Regime stability character function of the entropy

Table 3 : Stabilité du régime en fonction de l'indice d'entropie

p_i	Character of the regime	Entropy
95%	Very stable	1.188
90%	Very stable	1.950
85%	Stable	2.536
80%	Stable	3.000
75%	Relatively stable	3.374
70%	Relatively stable	3.665
65%	Relatively stable	3.885
60%	Relatively unstable	4.038
55%	Relatively unstable	4.128
50%	Unstable	4.158

The total entropy computed for a certain pattern is then compared with the entropy corresponding to a particular value of p_i which results in the establishing the degree of stability. In Table 4 the entropy and the stability of the river flow regimes established for each characteristic zone are presented.

Mention is made that very stable and stable types of regimes have been found in the high mountainous zones of Switzerland and Romania where the feed in high flows from the melting of the

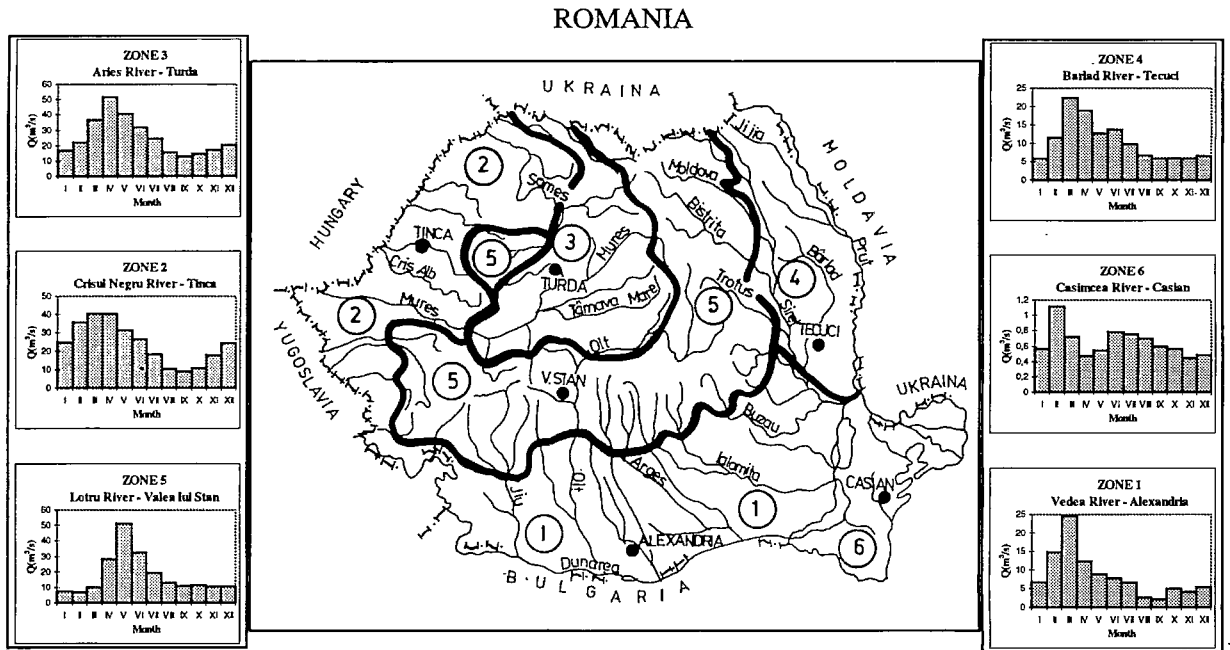

(a)

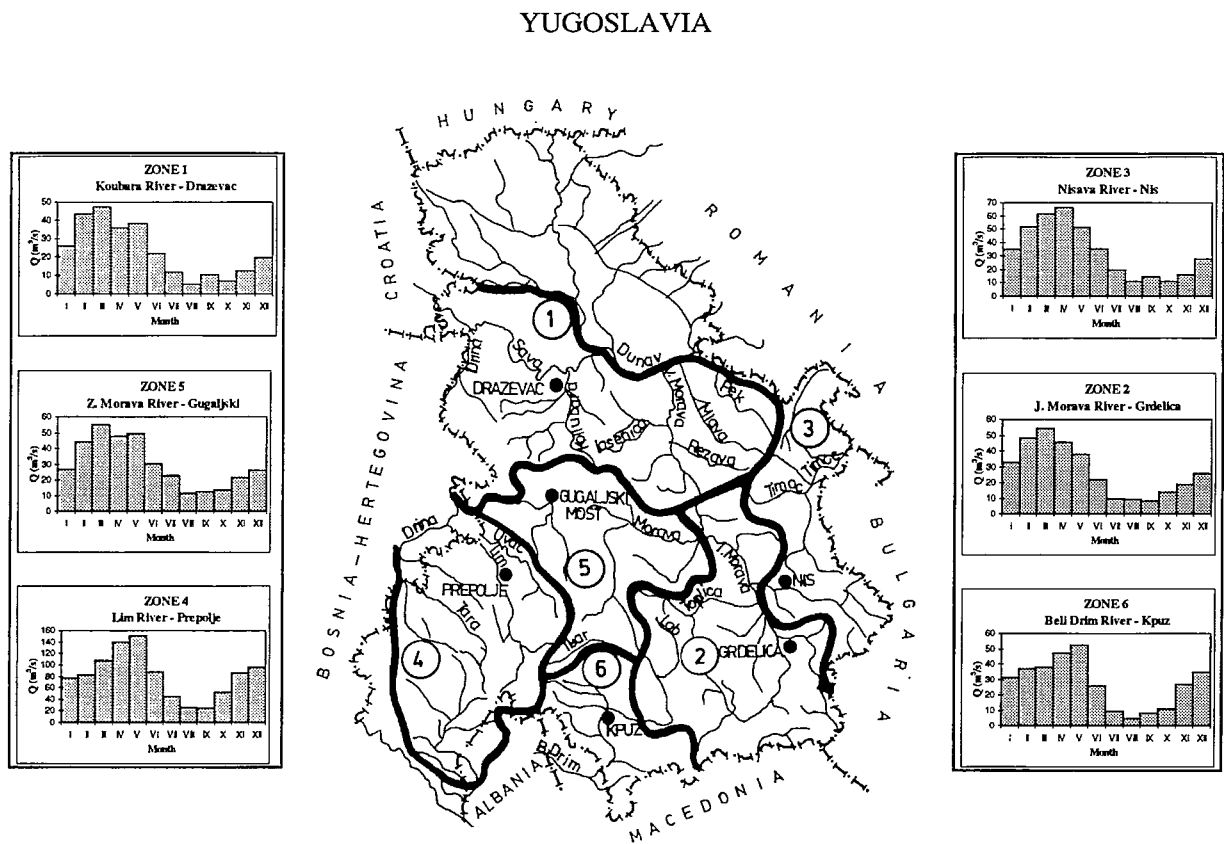

(b)

Figure 4 : Mapping of the river flow regime zones for Romania (a) and Yugoslavia (b)

Figure 4 : Cartographie du régime des zones étudiées pour la Roumanie (a) et la Yougoslavie (b)

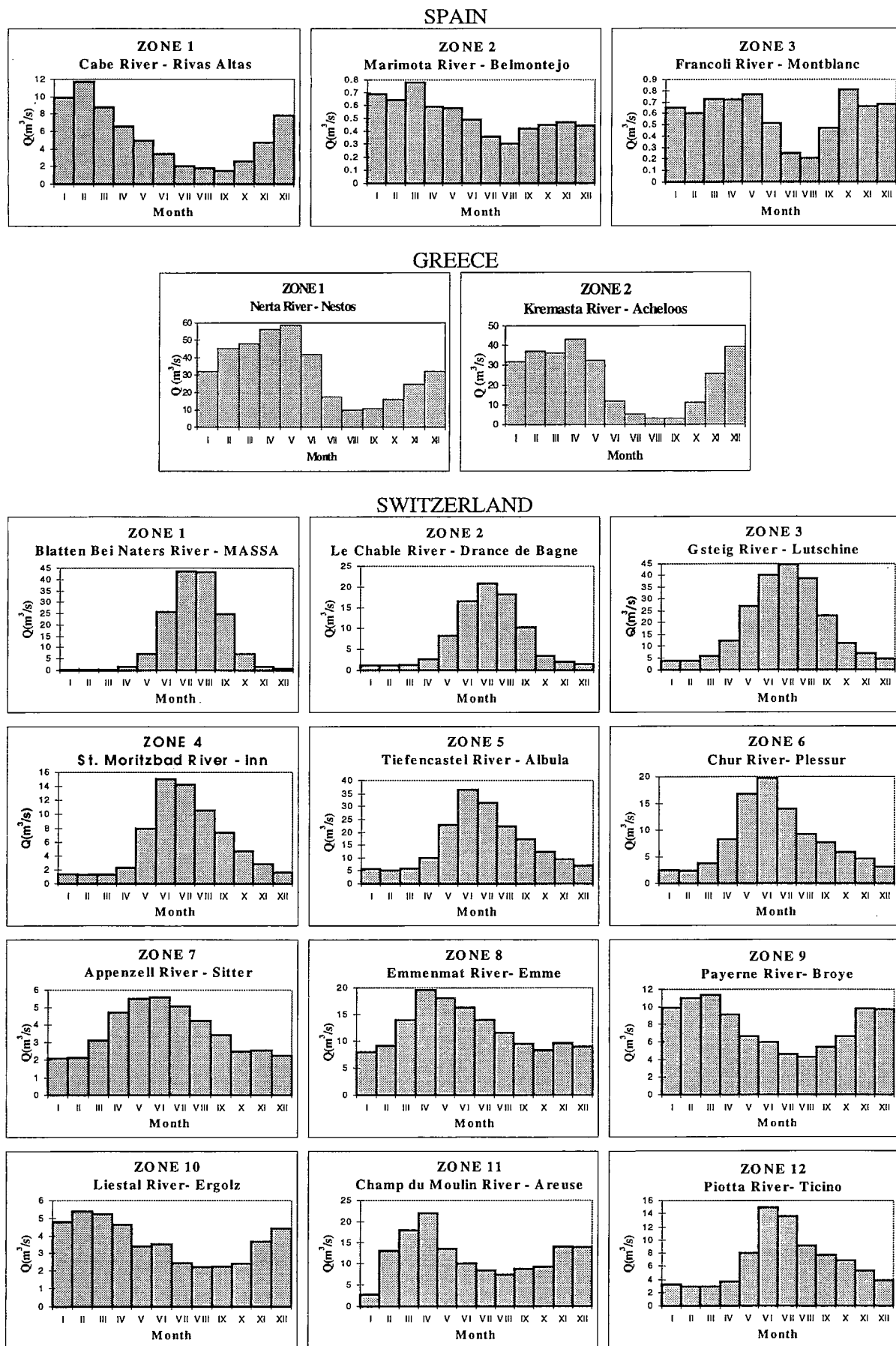

Figure 5 : Mean monthly flow defining several regimes types in Spain, Greece and Switzerland
 Figure 5 : Débits mensuels moyens caractérisant divers types de régimes en Espagne, Grèce, Suisse

glaciers and snow (which is significant as compared with the rainfall) occurs with some regularity in time and the low flows are strongly influenced by the river frost.

Table 4 : Stability of the regimes types for the considered countries from FRIEND-AMHY area

Table 4 : Stabilité des types de régimes, pour les pays traités de la zone FRIEND-AMHY

Zone	Entropy	p _i (%)	Stability
ROMANIA			
1	3.852	66.0	Rel. unstable
2	3.805	67.0	Rel. unstable
3	3.659	71.0	Rel. stable
4	3.847	66.0	Rel. unstable
5	2.769	83.0	Stable
6	4.158	50.0	Unstable
SPAIN			
1	3.194	77.0	Rel. stable
2	3.365	74.5	Rel. stable
3	3.403	73.5	Rel. stable
GREECE			
1	2.910	81.0	Stable
2	2.182	88.5	Stable

Zone	Entropy	F (%)	Stability
SWITZERLAND			
1	1.340	94.0	Very stable
2	1.933	90.0	Very stable
3	1.527	93.0	Very stable
4	1.129	95.5	Very stable
5	1.249	94.5	Very stable
6	2.028	89.0	Stable
7	3.379	74.5	Rel. stable
8	3.580	71.2	Rel. stable
9	3.758	66.5	Rel. unstable
10	3.487	73.0	Rel. stable
11	3.797	66.0	Rel. unstable
12	2.578	84.5	Stable

Relatively stable regimes have been found in the medium altitudes (ranging between 800÷1200 m) from Romania, Spain and Switzerland where the rainfall feed caused by a particular atmospheric circulation has a more stable periodicity of occurrence.

Unstable and relatively unstable regimes are found in the low zones where the flows are of the rainfall-snowmelt origin and when during some winters with much snow the earlier snowmelt in the spring time is not synchronous with the rainfall period (which is usually April-June).

6 Conclusions

- The significant variation in altitude of a zone or catchment subject to the influence of a particular climate leads to a differentiation of several micro-types of flow regimes. If a certain zone is found under the control of the intersection of many atmospheric circulation the micro-regime is a result of their combination with the altitude influence.
- An appropriate index of the stability of a particular flow regime is the total entropy of the occurrence of the characteristics discriminating a flow pattern.

Stability of river flow regimes

Stabilité des régimes d'écoulements en rivières

I. Krasovskaia, L. Gottschalk

1 Introduction

A flow regime describes the average seasonal behaviour of river flow. This characteristic of river runoff is important for sustainable environmental management and in particular for rational use of water resources. An inherent characteristic of a flow regime is its stability, i.e. regularity of the seasonal pattern. This pattern can demonstrate more or less similar temporal distribution of periods with high and low flow during each individual year, i.e. a stable regime, or it can alternate between a couple of different patterns during individual years, i.e. an unstable regime. Seasonality of river flow is by tradition described on the basis of long-term average values, which tell nothing about the stability of the flow regime. Meanwhile, flow stability represents an important environmental constraint for many aquatic species and operational water management schemes rely upon certain stability of seasonal flow patterns.

Being the product of climatic and physiographic conditions in a basin, river flow regimes reflect the character of these two factors. Natural or man-induced changes in basin's environment and climate are therefore inevitably followed by changes in river flow regimes and their stability. An objective river flow regime classification, having among its discriminating criteria also stability of seasonal flow patterns, expressed in quantitative terms, offers a reference frame, necessary to follow these changes in time and to be able to predict a future character of flow regimes. The aspect of variation of river flow regimes in time added a new temporal dimension to the, by tradition, static description of seasonal flow patterns. This new temporal dimension necessitates frequent updating of the flow regime classification, which with regard to large data sets is hardly feasible, unless it is computer-performed.

Alongside with the development of the classification algorithms, the problem of stability of flow regime types, assigned on the basis of long-term mean values, have been investigated (Krasovskaia et al., 1993). The results indicated that these types can be different, dependent on, for example, the length of the records. For some regime types the flow regime type assigned in this way differs from the one shown by the majority of years, when each year was classified separately. These results demanded further investigation of the stability of seasonal flow patterns.

The topic of stability of river flow regimes has not been approached earlier in a systematic way and with the use of a large number of long data sets, representing different environmental conditions. This paper presents some results of the research on the stability of river flow regimes performed in the frame of FRIEND Project 3. The following methods, which might provide an adequate characterization of river flow regimes in a changing environment, inclusive their type, stability and sensitivity to changes in climatic variables, have been developed and applied recently to the FRIEND data sets :

- A method for quantification of stability of river flow regimes.
- An approach to measure sensitivity of stability of flow regimes to climatic fluctuations.
- A method for objective grouping of flow regimes with consideration of their stability, including an objectively formulated "stopping rule" in a hierarchical grouping procedure.

A brief presentation of these methods as well as the results of analyses based on them are given below.

2 Quantification of the stability of river flow regimes

The concepts of entropy, transinformation and minimum cross-entropy have been used to quantify the stability of river flow regimes, their sensitivity to changes in climatic conditions and grouping of series into flow regime types with stability as one of the discriminating criteria.

To quantify the regularity of simulated and observed seasonal flow patterns, the instability index, based on the concept of entropy, was used (Krasovskaia, 1995). When calculating the instability index, an appearance of flow maxima/minima within one of n respective discriminating periods is regarded as coming from events E_1, E_2, \dots, E_n , which form a complete system in the sense that it is certain that exactly one of them will occur. Thus, if their probabilities are p_1, p_2, \dots, p_n , they add up to one :

$$\sum_{i=1}^n p_i = 1; \quad p_i \geq 0, i = 1, \dots, n \quad (1)$$

A measure of the uncertainty of an experiment, called entropy of the experiment - H , (Shannon, 1948) can be applied to characterize the uncertainty of the appearance of a respective maximum/minimum within a discriminating period :

$$H = - \sum_{i=1}^n p_i \ln(p_i) \quad (2)$$

The higher the entropy value, the smaller is the probability of observing the flow regime pattern, assigned to a series, during each individual year.

Using the property of additivity of entropy, the entropy of a flow regime type is calculated as a sum of the entropy of maxima (H_{\max}) and minima (H_{\min}) :

$$H = H_{\max} + H_{\min} \quad (3)$$

Comparisons of the stability of different flow regime types become easier when a relative instability index is used, which shows the stability of flow as the percentage of the maximum possible for this regime type. Entropy reaches its maximum value when all possible events E_1, E_2, \dots, E_n are equally probable: $p_1 = p_2 = \dots = p_n = 1/n$ (see, e.g. Ventsel, 1964). The maximum possible value of the instability index for a regime type is calculated with a consideration of the number of maxima and minima, used in the discriminating criteria for this particular type. The instability index characterizes a regularity with which certain periods of high/low water occur within their respective discriminating periods during each individual year. The lower the value of the index the more stable is the regime type.

The instability index characterizes flow observed under given climatic conditions (during the observation period) and in this sense is unconditional. When forecasts for future climatic conditions are involved, the uncertainty of the forecasted states should be considered. Krasovskaia (1996b) suggested to use for this purpose a conditional instability index, defined as a complete conditional entropy (see, for example, Ventsel, 1964) :

$$H(Y|X) = - \sum_{i=1}^m p_i \sum_{j=1}^n P(y_j|x_i) \ln P(y_j|x_i) \quad (4)$$

where $P(y_j|x_i)$ is the conditional probability that system Y (a flow regime) will be in state y_j under the condition that system X (mean annual temperature) is in state x_i ; m is the number of states (e.g. a temperature rise of $+1^\circ\text{C}$, $+2^\circ\text{C}$ or $+3^\circ\text{C}$), p_i is the probability that X is in state x_i and n as defined in equation (1).

The sensitivity of the stability of a flow regime to a temperature rise can be expressed, using the concept of transinformation from the Information theory, as a difference between the instability index for a long-term historical period or period, simulated for "zero-change" in temperature, and for the observed or simulated period, conditioned on temperature states :

$$D = H - H(Y|X) \quad (5)$$

where D is sensitivity, a non-negative value which describes the decrease of entropy of the system Y as a result of information about the state of system X .

Flow regime classifications usually do not contain the stability of flow as one of the discriminating criteria and the value of the instability index in this case is obtained as the mean for the series with the same regime type. In order to include the stability of the seasonal flow patterns into the discriminating criteria Krasovskaia (1996a) suggested a hierarchical aggregation procedure based on minimization of the of Kullback-Liebler's cross-entropy (Kullback & Liebler, 1951).

A set of possible river flow regimes for an ensemble of M flow series can be defined in terms of probabilities p_{ig}^* , $i=1, \dots, n$; $g=1, \dots, G$, where g denotes the flow regime type (of totally G types). It is assumed that these probabilities are known (prior probabilities) and are used to predict the flow regime for a series j .

Let the probabilities p_{ij} , $i=1, \dots, n$; $j=1, \dots, M$ be now a realization of the prediction of the flow regime for a series j . These probabilities will here be seen as posterior probabilities. Information inaccuracy, contained in the posterior probabilities p_{ij} (flow regime for a series j) in relation to the prior probabilities p_{ig}^* (flow regime of type g) is expressed as (Theil, 1967) :

$$I(p|p^*) = \sum_{i=1}^n p_{ij} \log(p_{ij}/p_{ig}^*) \quad (6)$$

If a prediction is made that a regime of type g is applicable for a set S_g of flow series, then a joint measure of information inaccuracy for this set can be expressed by :

$$I_g(p|p^*) = \sum_{j \in S_g} \sum_{i=1}^n p_{ij} \log(p_{ij}/p_{ig}^*) \quad (7)$$

Assigning each of the M series one of the G regime types leads to the following inaccuracy of the classification :

$$I_G(p|p^*) = \sum_{g=1}^G \sum_{j \in S_g} \sum_{i=1}^n p_{ij} \log(p_{ij}/p_{ig}^*) \quad (8)$$

Equation (8) describes the function that is minimized in a hierarchical procedure. As a part of this method, an objective formulation of a "stopping rule" in hierarchical grouping procedure has been elaborated. This "stopping rule" relies upon statistical criteria for the difference between probabilities of satisfying certain discriminating criteria and is thus directly related to the theoretical concept of the approach for grouping (for more details see Krasovskaia, 1996a).

3 Sensitivity of the stability of river flow regimes to a temperature rise

Using the method described above the instability index has been determined for the identified Scandinavian and European flow regime types, which demonstrated a broad spectrum of values of this index. Snowmelt-dominated regime types in general proved to be most stable, while those both snowmelt and rain-fed were most unstable. Table 1 offers information on the obtained values of the instability indices for the flow regime type of the FRIEND-area (Krasovskaia et al., 1994).

It can be seen that, for example, The Southern Inland (H2L2), Baltic (H2L3), North-Scandinavian Inland (H1L2) and Baltic Inland (H1L3) flow regime types have very high values of the instability indices of 80%-90% of the maximum value, which corresponds to a less than 50% chance to find these types among the regimes of the individual years in the series that have been assigned these flow regimes. This is a typical case when it is practically impossible to tell which regime type is the most frequent one. The regimes of this group all belong to a group with a transition from snowmelt dominated types to rain dominated ones, which are extremely sensitive to small fluctuations in climate.

Table 1 : Instability indices for European river flow regimes (from Krasovskaia, 1995)**Table 1 : Indice d'instabilité pour les régimes d'écoulement de rivières européennes**

FLOW REGIME TYPE	INSTABILITY INDEX, %		
	Scandinavia	W. Europe	Scandinavia + W.Europe
North-Scandinavian H1L1	51	52	51
North-Scandinavian Inland H1L2	88	-	-
Baltic Inland H1L3	76	78	77
Northern Inland H2L1	71	-	-
Southern Inland H2L2	90	-	-
Baltic H2L3	86	-	-
Atlantic H3L3	72	51	53

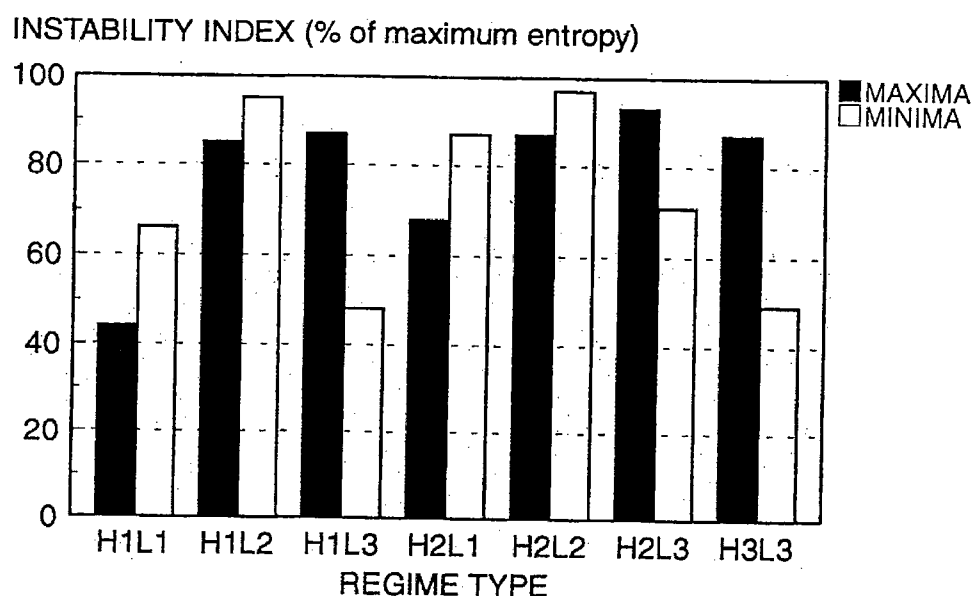
**Figure 1 : Instability index for maxima and minima of different flow regime types (From Krasovskaia, 1995)****Figure 1 : Indice d'instabilité pour les maximums et minimums de divers types de régimes d'écoulement**

The total instability index of a flow regime is a sum of instability indices of maxima and minima used for its identification. Figure 1 shows the instability indices for these separately. It is seen that the contribution of the stability character of maxima and minima to the total stability character of a flow regime can be very different. For example, for Baltic Inland (H1L3) and Baltic (H2L3) regime types the difference in the stability character of maxima and minima is striking. For both of them it is the maxima that give the regime its unstable character. The minima are more stable, especially for H1L3.

Using the suggested measure of sensitivity, the regional sample of Scandinavian river flow regimes has been used to study their sensitivity (both what concerns types and stability) to observed and simulated changes in mean annual and seasonal temperature. Both a "split-sample" technique, applied

to the long-term historical runoff records, and modelling the behaviour of seasonal flow patterns under the assumption of a number of certain temperature rise steps have been used. The latter approach offered a possibility to study also larger temperature rise steps (1° - 3°C), than those present in the historical records available ($\approx 1^{\circ}\text{C}$). Figures 2 and 3 show some examples of changes in the stability of different river flow regimes under the influence of the observed or modelled temperature change.

A parallel application of both approaches to a couple of series permitted to get insight into the order of magnitude of uncertainties connected with these two approaches, including those in scenarios for a possible temperature rise expressed in terms of probabilities.

River flow regimes with rain or mixed rain and snowmelt, as dominating flow formation factors, proved to be very sensitive already to small fluctuations in mean annual temperature and mean temperature for discriminating periods, especially what concerns their minima. The latter become more stable when the temperature rises and destabilize when it falls below the long-term average.

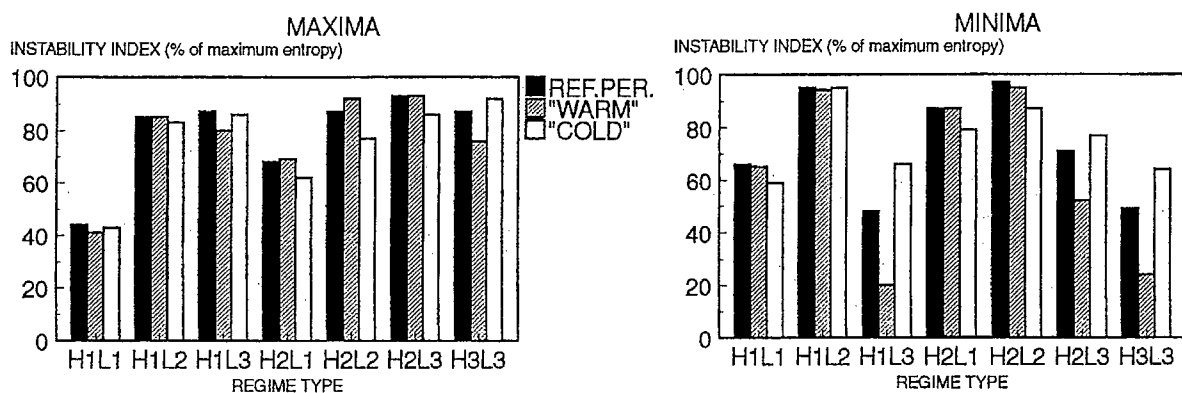

Figure 2 : Instability index for maxima and minima of different flow regime types conditioned on a temperature rise/fall of $\approx 1^{\circ}\text{C}$ with the probability of 1. (From Krasovskaia, 1996).

Figure 2 : Indices d'instabilité pour les maximums et minimums de divers types de régime, en réponse à des fluctuations de température de $\pm 1^{\circ}\text{C}$, probabilité 1

For snowmelt-dominated flow regime types these small fluctuations in temperature cause only very small changes. The regime patterns stabilize, in general, during the cold years and destabilize during the warm. However, when the sensitivity of the flow regimes, simulated for larger temperature rise steps, was studied, also these latter regime types demonstrated some changes. They showed first a general tendency for destabilization and then shifted their regime types to rain-dominated via transition types, becoming again more stable. Geographical location and altitudinal position of the series, as well as their basin size, proved to be of importance for sensitivity to a temperature rise.

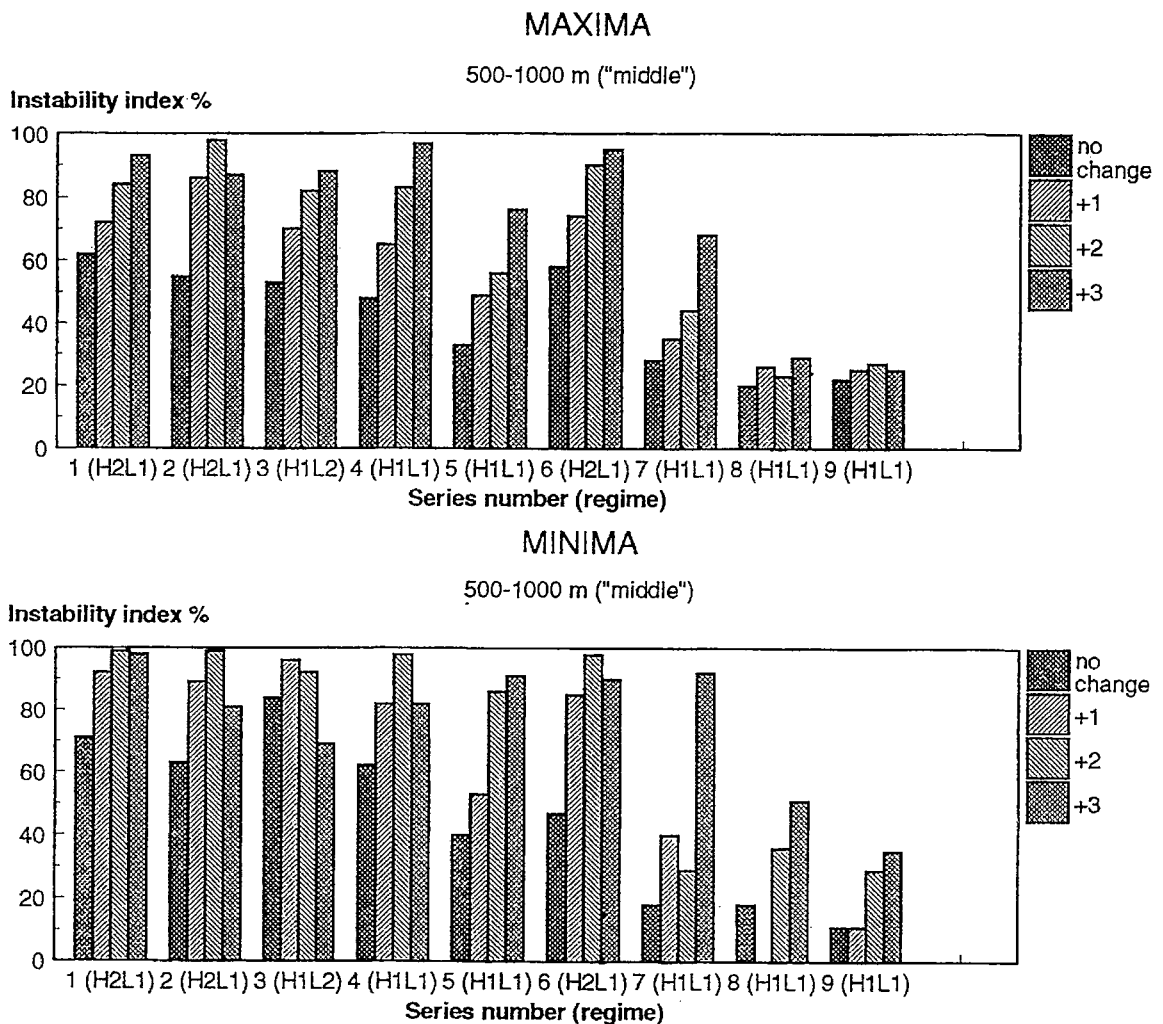

Figure 3 : Sensitivity of the stability of seasonal flow patterns to predicted temperature rise steps. (From Krasovskaia & Saelthun, 1996)

Figure 3 : Sensibilité de la stabilité des variations saisonnières à la hausse de la température prévue

In general, about 20% of the series in the Scandinavian data sample changed their regime type when the mean annual temperature shifted about $\pm 1^{\circ}\text{C}$ (average across all series). Higher winter-spring flow volumes and lower flow volumes during summer were typical for the years with the mean annual temperature above the long-term mean, especially in southern parts of the region.

The results of sensitivity studies performed on different data sets, analyzing historical records and simulating runoff for the assumed temperature rise step, are well in accordance with each other. They are also in general agreement with the findings of other Scandinavian studies of river runoff sensitivity to changes in climatic variables.

4 Grouping of monthly flow series into regime types with regard to the stability of seasonal patterns

The grouping method has been successfully applied for grouping monthly flow series into regime types for different formulations of discriminating criteria. Figure 4 shows an example of grouping applying the discriminating criteria of the Scandinavian flow regime classification (Krasovskaia &

Gottschalk, 1992). Table 2 describes the flow regime groups obtained. The grouping seems to be plausible with respect to climatic conditions in the region.

Table 2 : Identified flow regime types (Scandinavian discriminating criteria) (From Krasovskaia, 1996a)

Table 2 : Types de régimes identifiés d'après le critère scandinave

REGIME TYPE	GROUP COMBINATIONS OF MAXIMA AND MINIMA
Spring-early summer high water and winter low water	1-1,2-1,3-1,2-2,3-2,6-2,6-3,6-4,7-3,7-4,8-4,9-2,9-3
Spring-summer high water with a possible secondary high water in autumn and winter low water	4-2,5-3
High water in winter-early spring, low water in summer	11-7,11-8,12-8,13-8
Spring-early summer high water, summer low water	6-7,8-6,8-7,8-8,9-6,10-6,10-7
Spring-early summer high water and low water in summer and winter	6-5

The main advantage of the suggested approach is that it allows to consider the regularity of the seasonal patterns, neglected in most other classifications. It can be applied to monthly flow series for individual years (in order to consider the seasonal regularity of flow), as well as for aggregation based on the long term monthly means. The approach allows different formulations of the discriminating criteria, provided they are quantitative.

5 Conclusions

The study presented is performed on regional data and is the first one to take up systematically the problem of stability of river flow regimes, both in stationary conditions and under the influence of climatic change. This aspect has been neglected in other studies. The stability of river flow regimes, if taken up at all was described in purely qualitative terms or in combination to different monthly "coefficients", operating on long-term means.

Quantification of the stability of river flow regimes is another advantage of this study. The strictly defined measure of the sensitivity of stability of flow regimes helped to analyze the latter in a systematic way. The analyses of historical observations and those simulated for an assumed temperature rise state indicated that flow regime types with rain or both rain and snowmelt as the main flow formation factors are sensitive to already such small changes in the average annual temperature as $\pm 1^\circ\text{C}$. Snowmelt dominated flow regime types proved to be more resistant and showed destabilization and change of the seasonal patterns only when the temperature rise step was much higher ($+3^\circ\text{C}$). The preliminary analyses with the use of the suggested sensitivity measure indicated that the order of magnitude of changes caused by the uncertainties in climatic scenarios is comparable to that caused by the annual mean temperature rise of $+1^\circ\text{C}$. Finally, the introduced method for grouping offers better possibilities to monitor changes in the stability of river flow regimes united in one regime group under the influence of man-induced or natural changes in the environment.

The compact entropy-based measure of stability of river flow regimes opens for its further analyses in terms of the theory of chaos. It has been shown, for example, how increasing entropy (destabilization) leads to the change of the state (flow regime type) and decrease in entropy, as well as what magnitude of the external disturbance (a temperature rise step) is necessary to provoke such behaviour.

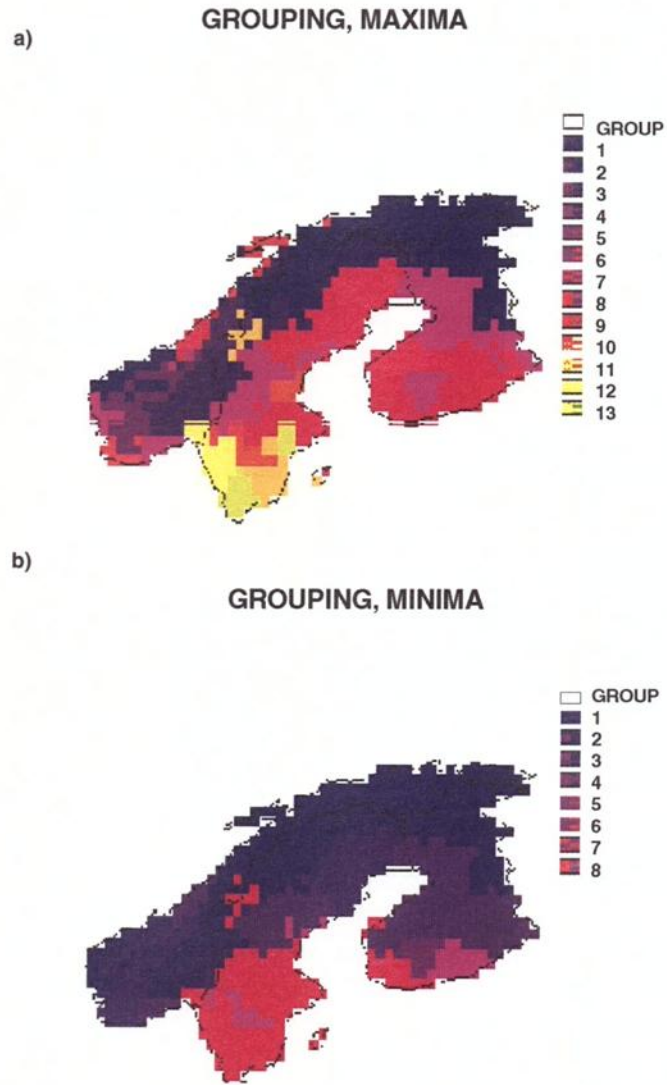

Figure 4 : Grouping of maxima and minima for Scandinavian river flow regimes (From Krasovskaia, 1996).

Figure 4 : Classes d'agrégation pour les maximums et minimums des régimes d'écoulement des rivières scandinaves

Régimes tropicaux et tendances climatiques

Tropical regimes and climatic trends

E. Servat, J.E. Paturel, H. Lubès-Niel, B. Kouamé, J.M. Fritsch

1 Introduction

Depuis plus de vingt ans maintenant, les pays sahéliens d'Afrique de l'ouest et centrale sont soumis à une sévère sécheresse. Elle se traduit par des déficits pluviométriques importants dont les conséquences sont souvent graves. Dans ces régions, en effet, la maîtrise des rares ressources en eau est un préalable indispensable à toute activité. Les travaux de Nicholson *et al* (1988) et ceux de Hubert et Carbonnel (1987), en particulier, ont permis de caractériser l'apparition du phénomène à la fin des années 1960 et au début des années 1970 ainsi que son intensité. Cependant, plus au sud, dans des régions d'Afrique aux climats plus humides, la sécheresse se fait également ressentir. Ses répercussions y sont généralement moins sévères, la ressource en eau restant relativement abondante. Néanmoins, là aussi, la baisse avérée de la pluviométrie et la diminution des apports en eau de surface ont des conséquences dommageables tant du point de vue de l'environnement que de celui des différents secteurs d'activité économique.

Une étude est actuellement en cours dans le cadre du programme ICCARE (Identification et Conséquences d'une variabilité Climatique en AfRIque de l'ouest non sahélienne) mené par l'ORSTOM au sein du thème "Variabilité climatique" du projet FRIEND AOC. Ce programme comprend plusieurs phases dont une consacrée aux modifications enregistrées par les régimes pluviométriques de ces régions tropicales et une autre aux régimes d'écoulements. Les résultats de cette deuxième phase sont bien évidemment étroitement liés à ceux obtenus sur les précipitations. Nous présenterons ici les premières conclusions auxquelles nous avons pu aboutir tant en ce qui concerne les précipitations que les débits (Paturel *et al*, 1997).

2 Données et méthodes

Les données utilisées proviennent de la Banque de données du Projet FRIEND AOC. L'étude réalisée a principalement concerné la période 1950-1989. L'information pluviométrique y est importante et bien répartie sur l'ensemble de la zone d'étude (près de 200 postes de mesure). L'information débitométrique est, quant à elle, moins dense, tant dans l'espace que dans le temps.

Des outils d'interpolation et de cartographie, ainsi que des méthodes statistiques de détections de ruptures au sein de séries chronologiques ont permis l'exploitation de ces données. Rappelons ici qu'une "rupture" se définit comme un changement de la loi de probabilité de la série étudiée.

Des cartes d'isovaleurs de précipitations annuelles et d'indices pluviométriques annuels ont été établies. L'indice pluviométrique, reprenant la définition donnée par Nicholson *et al* (1988), est une variable centrée réduite qui traduit une "intensité" d'excédent ou de déficit pluviométrique annuel dans le cas où la variable étudiée est la pluviométrie annuelle. Les méthodes statistiques de détection de ruptures ont été choisies (Lubès *et al*, 1994) à partir de critères de robustesse et après de nombreux essais effectués sur des séries chronologiques artificiellement perturbées. Ce sont finalement: test de corrélation sur le rang afin de déterminer le caractère aléatoire ou non de la série, et, pour détecter un changement de la moyenne dans les séries étudiées, test de Pettitt, statistique de Buishand, procédure bayésienne de Lee et Heghinian et procédure de segmentation de Hubert. Ces méthodes font

l'hypothèse d'une stationnarité de la variance des séries et sont adaptées à la détermination d'une rupture unique (à l'exception de la méthode de segmentation de Hubert).

3 Variabilité des régimes pluviométriques

Au cours des quatre décennies plus particulièrement étudiées, on note une tendance au glissement des isohyètes vers le Sud, et donc une diminution de la pluviométrie. Toutefois, c'est durant la décennie 1960 que la pluviométrie moyenne annuelle a été la plus forte de la Côte d'Ivoire au Bénin. Durant les années 1980, tout le Nord de la zone étudiée a une pluviométrie inférieure à 800 mm, ce que l'on n'observait pas durant la décennie 1950. La tendance à la diminution de la pluviométrie moyenne annuelle semble débiter pendant la décennie 1970 et s'amplifier pendant les années 1980. Aucune des régions de la zone d'étude n'est épargnée par ce phénomène. Même les régions les plus pluvieuses sont affectées (Figure 1).

La figure 2 traduit des intensités de déficit ou d'excédent pluviométrique des décennies 1950 et 1980 par rapport à la période de référence. Globalement, les décennies 1950 et 1960 sont excédentaires alors que les deux décennies suivantes apparaissent comme déficitaires. Les régions les plus intensément touchées par cette baisse des précipitations se situent principalement au nord et à l'ouest de la zone d'étude, c'est à dire dans les secteurs habituellement les moins et les plus arrosés. Vers l'est on observe le même phénomène mais avec une moindre ampleur.

Les résultats des tests de détection de rupture confirment que ce phénomène est plus marqué en Afrique de l'Ouest qu'en Afrique Centrale, comme cela avait été souligné auparavant. En cas de rupture dans les séries chronologiques, les déficits calculés de part et d'autre sont généralement de l'ordre de 20%, mais ils peuvent parfois être supérieurs à 25%. Les dates d'occurrence des ruptures détectées se regroupent autour des années 1969-1970 (Servat et al, 1996; Paturel et al, 1996).

Les représentations cartographiques et les méthodes statistiques de détection de ruptures s'accordent donc sur la réalité d'une importante baisse de la pluviométrie sur l'ensemble de la zone non sahélienne d'Afrique de l'Ouest et Centrale. Si l'amplitude du phénomène, apparu aux alentours des années 1970, n'est pas uniforme, toutes les régions ont cependant été touchées. En saison sèche comme en saison des pluies, toutes les périodes de l'année ont subi cette diminution des précipitations. Cette variabilité est en tous points comparable à ce qui avait été décrit jusque là plus au nord dans le Sahel. Bien que la région étudiée soit qualifiée d'"humide", cette modification du régime pluviométrique ne peut qu'avoir des conséquences importantes sur la disponibilité des ressources en eau de surface.

4 Variabilité des régimes hydrométriques

En matière d'hydrométrie, l'information disponible n'est malheureusement pas aussi dense qu'elle peut l'être pour la pluviométrie. Les stations hydrométriques sélectionnées sont, cependant, suffisamment nombreuses pour traduire de manière significative, à l'échelle régionale, la réalité de la variabilité temporelle des ressources en eaux de surface. Comme pour la pluviométrie, un intérêt plus marqué a été porté à la période 1950-1989 qui correspond à une densité maximale de données disponibles.

Les bassins versants contrôlés par les stations étudiées sont de superficie extrêmement variables. Néanmoins, la quasi totalité des stations étudiées fait état d'une nette diminution de l'hydraulicité depuis près de vingt cinq ans maintenant. En effet, depuis le début de la décennie 1970, à quelques rares exceptions près, toutes les années apparaissent comme ayant une hydraulicité inférieure à la moyenne, traduisant en cela une baisse des ressources en eau de surface.

Les séries chronologiques de débits moyens annuels ont été étudiées à l'aide des méthodes de détection de ruptures évoquées plus haut. Les résultats montrent que sur les 95 stations retenues à ce niveau de l'étude, 77 (soit légèrement plus de 80%) présentent une rupture. La grande majorité est localisée entre 1968 et 1972. La précision de cette localisation dans le temps souligne, si besoin en était, le lien indiscutable qui existe entre la baisse de la pluviométrie et la diminution des écoulements de surface en Afrique de l'Ouest et Centrale non sahélienne. De part et d'autre des dates de rupture dans les séries chronologiques, et sur la période 1950-1989, on atteint des différences importantes en ce qui concerne les débits moyens annuels. Elles sont rarement inférieures à 30% et parfois supérieures à 55 voire 60%. Le tableau 1 présente quelques valeurs moyennes de déficit pour certains grands fleuves et pays. Ces valeurs doivent être prises comme un ordre de grandeur dans la mesure où elles n'ont pas toutes été calculées dans les mêmes conditions: périodes de calculs pouvant être légèrement différentes et nombre de stations prises en compte très variable (de 2 sur le Fleuve Sénégal à 13 en Côte d'Ivoire). Néanmoins on constate, à l'examen du tableau 1, que la diminution des écoulements, et donc des ressources en eau de surface, est considérable dans ces régions situées au sud du Sahel. Le déficit d'écoulement atteint, en effet, près de 45% en général. C'est à dire que, dans cette région et à quelques exceptions près, les volumes qui transitent dans les cours d'eau ont diminué de près de moitié depuis le début de la décennie 1970, ce qui est considérable.

Tableau 1 : Ordres de grandeur (en %) de certains déficits d'écoulements annuels calculés depuis la date de rupture observée dans les séries chronologiques et sur la période 1950-1989

Table 1 : Assessment (as %) of some annual runoff deficits computed since the date of the break observed in the time series of the 1950-1989 period.

Fleuve ou Pays	Déficit d'écoulement (%)
Fleuve Niger (stations du Mali et de Guinée)	40
Fleuve Sénégal (stations du Sénégal et du Mali)	60
Bénin	52
Burkina	48
Centrafrique	29
Côte d'Ivoire	47
Guinée	39
Tchad	47
Togo	44

Le décalage quantitatif qui semble exister entre les déficits pluviométriques et hydrométriques pourrait être lié à un déficit d'alimentation des cours d'eau par les nappes phréatiques (Mahé et Olivry, 1995). Les conditions pluviométriques persistantes, l'augmentation progressive des coefficients de tarissement et la dégradation continue du niveau des nappes ne permettant pas à la relation "nappe-rivière" de fonctionner comme elle le faisait avant les années 1970.

5 Conclusion

Comme on vient de le montrer, les régions situées au sud du Sahel ont également subi une variabilité climatique. Les régions dites "humides" d'Afrique de l'Ouest et Centrale ont vu leur régime hydrologique modifié depuis plus de vingt cinq ans maintenant. Ces modifications se font nettement ressentir tant au niveau de la pluviométrie que des débits des cours d'eau.

Sur l'ensemble de la zone étudiée, les régimes pluviométriques ont subi d'importantes modifications (glissement généralisé des isohyètes vers le sud) qui se traduisent par des diminutions de hauteurs annuelles précipitées pouvant atteindre 20 à 25%. Cette baisse des précipitations affecte chaque mois

qu'il soit de saison sèche ou humide. On constate également, dans bon nombre de zones de savane, une tendance à passer d'un régime climatique "guinéen" à un régime "soudanien" plus sec.

Les régimes hydrométriques ont également subi de profondes modifications. Dans toute la zone étudiée, les volumes écoulés ont considérablement diminué, cette baisse atteignant près de 45% en moyenne et pouvant aller jusqu'à plus de 60% par endroits. Une étude plus complète est actuellement en cours qui s'intéresse aux manifestations de ces modifications: basses eaux, hautes eaux, tarissement, forme des crues, etc.

Du point de vue de la ressource et de son utilisation, il est évident que de telles modifications ne sont pas sans conséquences. L'agriculture, l'alimentation des retenues et la production hydroélectrique, entre autres, sont fortement pénalisées par cette diminution des ressources. Les conséquences de ce phénomène sont donc très inquiétantes en ce qui concerne le bon fonctionnement et la rentabilité des projets déjà réalisés ou envisagés.

Remerciements

Les auteurs souhaitent remercier MM. A. Aka, J.F. Boyer, J.M. Masson, B. Marieu, M. Ouedraogo et M. Travaglio pour leur très large contribution à cette étude.

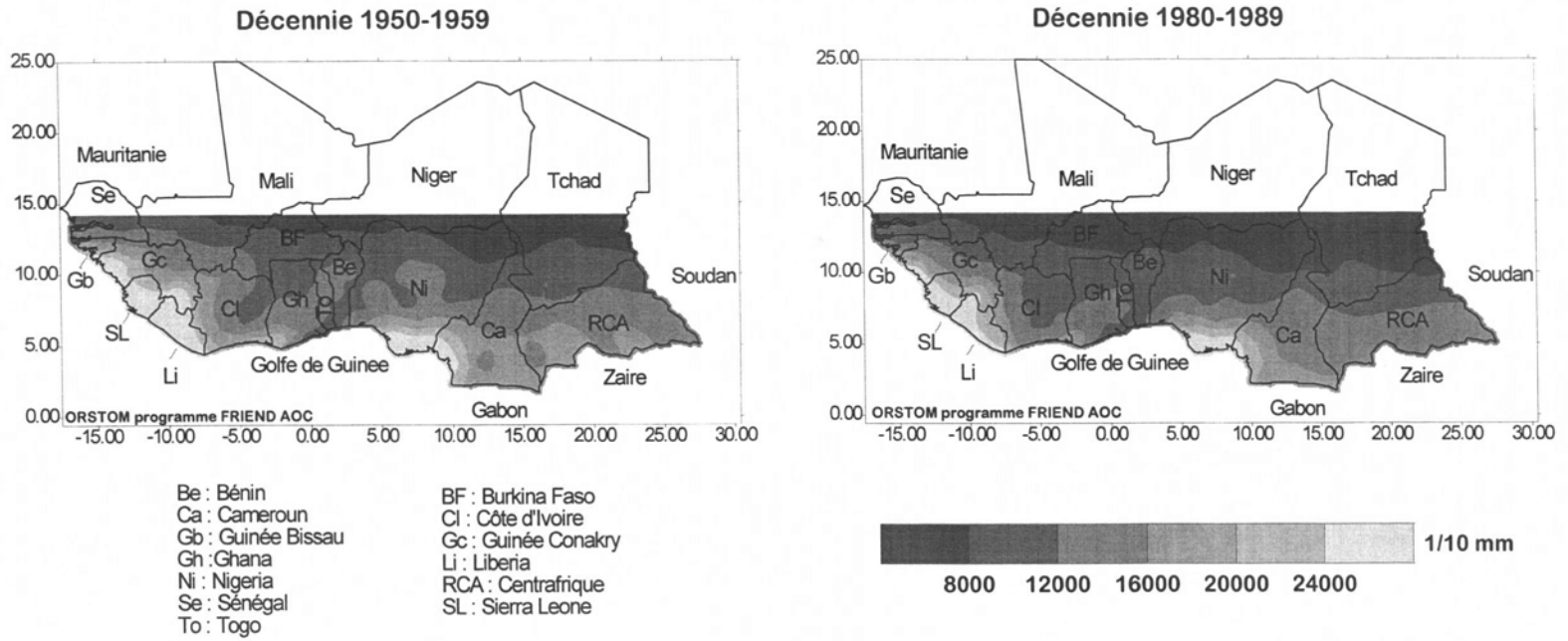

Figure 1 : Pluviométrie moyenne annuelle durant les décennies 1950 et 1980
 Figure 1 : Mean annual rainfall during decades 1950 and 1980

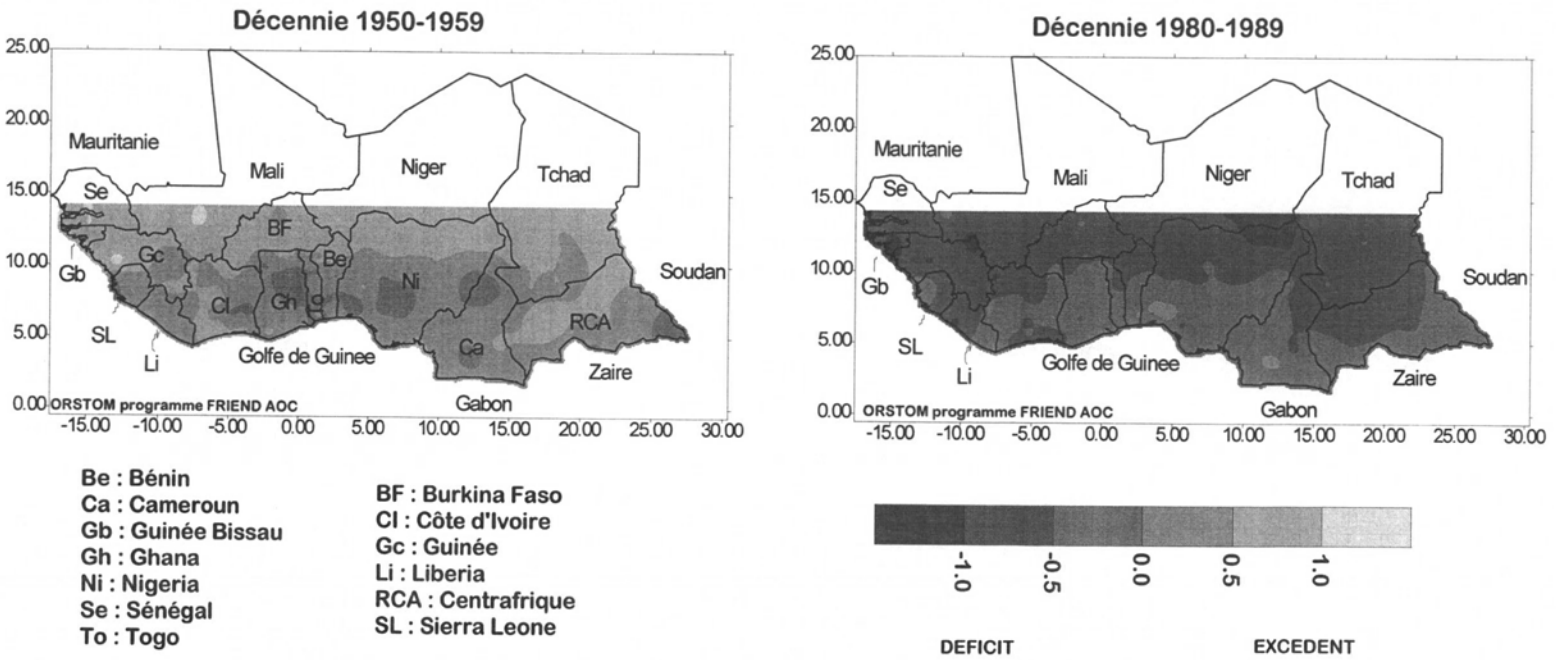

Figure 2 : Indices pluviométriques durant les décennies 1950 et 1980
 Figure 2 : Rainfall index during decades 1950 and 1980

Régionalisation hydrologique en Afrique de l'Ouest et Centrale et au Mali

Hydrological regionalization in Western and Central Africa and in Mali

G. Mahé, F. Bamba, J.P. Bricquet, M. Diabate, M. Diarra, J.F. Leroux, A. Soumaguel

Une partie des recherches effectuées en Hydrologie à Bamako au sein du programme EQUANIS (Etude de la Qualité des Apports du Niger Supérieur au Sahel) s'inscrit dans le cadre des thèmes de recherche de FRIEND AOC portant sur la Régionalisation des paramètres hydrologiques et sur la Variabilité climatique.

Ces actions de recherche portent sur deux échelles d'espace différentes: l'ensemble de l'Afrique de l'Ouest et Centrale, d'une part, et le bassin versant du Niger, des Monts de Guinée à Tombouctou (Koryoumé, 360 000 km²), sortie du Delta Central, étendu sur 3 pays, la Guinée, le Mali et la Côte d'Ivoire, d'autre part.

Plusieurs études de validation des méthodes utilisées à partir des résultats obtenus sur la première échelle spatiale (Afrique de l'Ouest et Centrale) ont été réalisées. Nous avons tout d'abord présenté une validation de la méthode utilisée pour le calcul automatique des lames écoulées (Mahé et al., 1994). Puis nous avons effectué une étude où l'on montre une bonne représentativité statistique des valeurs de pluie reconstituées par la méthode du vecteur régional (MVR) (Wotling, 1994 ; Wotling et al., 1995). On montre également (L'Hôte et Mahé, 1996) un recul vers le sud des isohyètes en Afrique tropicale au sud du Sahara au cours des années 1970-1989 par rapport à la période plus humide 1951-1969. Les bilans hydrologiques annuels des 34 plus grands fleuves d'Afrique de l'Ouest et Centrale de 1951 à 1989 (Mahé et Olivry, 1995) indiquent que toute l'Afrique de l'Ouest et Centrale est soumise à la sécheresse (Tableau 1), à des degrés divers, mais que les effets de celle-ci sont plus importants en Afrique de l'Ouest. La diminution des débits y est en effet beaucoup plus forte que celle des pluies, en relation semble-t-il avec l'augmentation des coefficients de tarissement des rivières de la région (Bricquet et al., 1995a).

Tableau 1 : Bilans hydrologiques vicennaux pour 5 bassins versants du Haut Niger en % de la normale 1951-1989

Table 1 : Vicennial hydrologic balances concerning 5 catchments from Upper Niger as a percentage of the 1951-1989 average.

BASSINS	PERIODES	PLUIE	LAME ECOULEE
BANI	1951-70	110	153
	1971-89	90	44
TINKISSO	1951-70	110	136
	1971-89	89	62
SANKARANI	1951-70	108	115
	1971-89	92	84
MILO	1951-70	104	113
	1971-89	96	86
NIANDAN	1951-70	104	109
	1971-89	96	91

En ce qui concerne le volet spatialisation des données hydrologiques et variabilité climatique, en particulier pour le bilan hydrologique du Niger et de ses sous-bassins, nous avons dans un premier temps mis en place les éléments : rassemblement de toutes les données pluviométriques, installation de la chaîne de traitement pluviométrique, vérification des données hydrométriques récentes. Ce travail a donné lieu à l'édition de plusieurs annuaires des précipitations (Soumaguel et al., 1996 ; Soumaguel, 1996a) ainsi qu'à la constitution des fichiers opérationnels pour le traitement et l'analyse des variations pluviométriques et à la délimitation des unités climatiques pour le traitement par la méthode du vecteur régional (Soumaguel, 1996b). Pour un bassin d'environ 360 000 km² 18 unités ont été délimitées couvrant une surface totale d'environ 900 000 km², soit une unité pour 50 000 km² en moyenne. Les postes pluviométriques retenus concernent 6 pays, et sont au nombre de 360 environ, soit 20 postes par unité. La densité du réseau d'étude est donc très élevée avec 1 poste pour 2 500 km². Cette phase est très importante puisque la reconstitution des données de pluie conditionne la qualité des lames d'eau calculées automatiquement et le bilan hydrologique. Nous avons défini trois fichiers opérationnels correspondant à trois périodes de temps différentes, le calcul des vecteurs régionaux sera effectué pour chacune de ces trois périodes, mais pour des unités identiques. Les bilans hydrologiques (P-E) ont été réalisés sur une période homogène de 39 ans (1951-1989) pour 5 sous-bassins du Niger amont et la cuvette lacustre (Bamba et al, 1995 ; Bricquet et al., 1995b ; Bamba et al., 1996a ; Diabaté, 1995 ; Bamba, 1996) (Figure 1). La diminution des pluies est moins forte en Guinée forestière sur le haut bassin du Niger, sous le vent des Monts de Guinée, où il pleut en moyenne interannuelle 1800 mm à 2200 mm par an. Elle est plus forte vers le nord et vers l'est. De même la diminution des écoulements y est moins prononcée, ce qui se traduit par une augmentation très modérée des coefficients de tarissement. Ces derniers ont été calculés pour plusieurs sous-bassins maliens et guinéens, mis à jour jusqu'en 1989 ou 1990 en données mensuelles ou journalières (Bamba et al., 1996b). L'étude des tarissements (Figure 2) aux stations principales du fleuve montre que la relation précipitations/écoulements a été fortement modifiée durant les années de sécheresse des deux dernières décennies, et que les caractéristiques des écoulements de crue ne sont en revanche que peu modifiés. Il est probable que ce sont les écoulements de base qui ont diminué. Enfin les premiers résultats indiquent que près de la moitié des eaux qui inondent le delta central (ou cuvette lacustre) est reprise par évaporation avant la sortie du delta, ceci ayant des conséquences non négligeables sur la concentration des éléments chimiques et sur la variabilité des équilibres réactionnels.

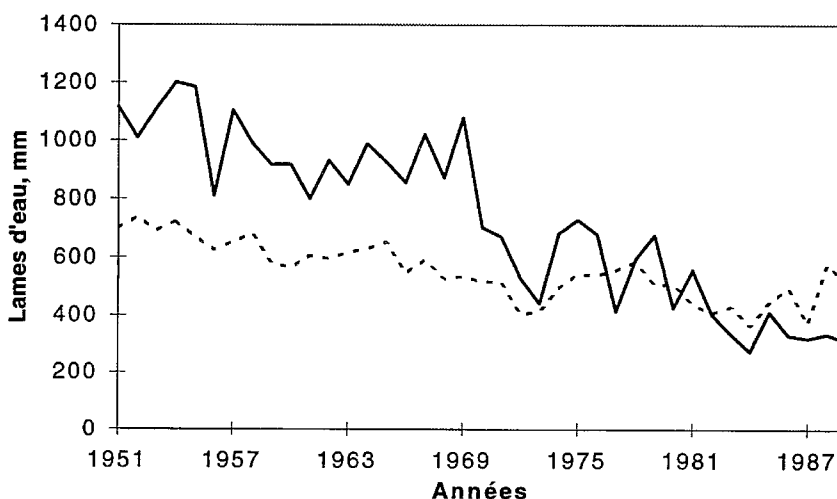

Figure 1 : Variation des apports dans la Cuvette Lacustre du Niger (ligne continue: lame d'eau écoulée entrant dans la cuvette par Ké-Macina et Douna; ligne discontinue: lame précipitée sur la cuvette)

Figure 1 : Modification of the water brought into the "Cuvette Lacustre" of Niger (full line: depth of water brought in the "Cuvette" at Ké Macina and Douna; dashed line: rainfall measured in the "Cuvette")

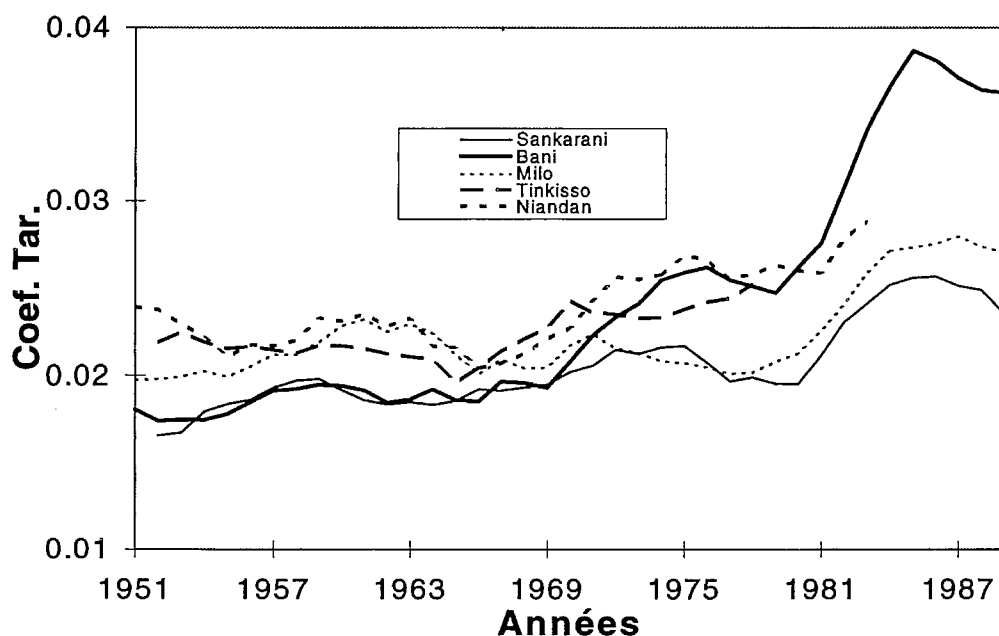

Figure 2 : Variation du coefficient de tarissement sur les cinq bassins versants du Haut Niger sur la période 1951-1989

Figure 2 : Modifications of the drying up coefficients for the five catchments of the Upper Niger during the 1951-1989 period

Nous proposons de suivre l'évolution des coefficients de tarissement à plusieurs stations hydrométriques, ces coefficients étant proportionnels à la vitesse de vidange des nappes, et de tenter de quantifier les pertes en volume de base au cours de la période sèche par rapport aux hydrogrammes annuels moyens pour la période humide. A partir du fichier de pluies annuelles prochainement réalisé sur la période 1920-1995, nous allons également calculer les bilans hydrologiques par sous-bassins depuis le début du siècle.

Régimes tropicaux et tendances climatiques dans le bassin du Congo-Zaire

Tropical regimes and climatic trends in the Congo-Zaire catchment

A.Laraque, D.Orange

Durant cette période 1994-1997, se déroulent dans le cadre de FRIEND AOC sur le bassin du Congo-Zaire, des études hydrologiques qui visent à mieux connaître et comprendre les variations spatio-temporelles des régimes d'écoulement des principaux tributaires de ce grand fleuve d'Afrique Centrale. A terme, des comparaisons sont envisagées avec les comportements des fleuves et rivières d'Afrique occidentale pour tenter d'expliquer les mécanismes hydroclimatiques régissant le fonctionnement des écoulements de la façade atlantique de ce continent.

Ces travaux sont menés à bien grâce à l'étroite et historique collaboration entre des chercheurs de l'ORSTOM et leurs homologues de la DGRST Congolaise et du Service de l'Hydrologie de la Direction de la Météorologie Centrafricaine, depuis les deux principaux observatoires que sont Brazzaville sur le Congo-Zaire et Bangui sur l'Oubangui, son deuxième affluent. Ces deux cours d'eau bénéficient aujourd'hui de chroniques de débits s'étalant sur pratiquement tout le XX^{ème} siècle. Ces dernières ont été stockées, critiquées puis corrigées dans d'importantes banques de données informatiques en liaison constante avec l'Observatoire Hydrologique de l'Afrique de l'Ouest et Centrale, qui, dispose de pages WEB mises à jour pratiquement en temps réel à Ouagadougou. Ces données ont permis des calculs de bilans hydrologiques précis sur toute la seconde moitié du siècle, pour tous les bassins versants des tributaires de rive droite du fleuve, autorisant dorénavant des comparaisons géographiques et des premières interprétations.

Leurs régimes sont étudiés et nous voyons comment ils ont été affectés différemment par les baisses d'écoulement de ces dernières décennies. Nous suivons aussi la répercussion des modifications des régimes du nord du bassin sur celui du grand fleuve à Brazzaville, qui contrôle 95% de son bassin versant.

Le bassin du Congo-Zaire, second de la planète par sa taille ($3,7.10^6$ km²) et par son débit (41 000 m³/s), est à l'origine de la moitié des apports en eau douce du continent africain à l'océan atlantique. Il présente une succession graduelle des régimes hydrologiques de ses affluents qui passent de tropical humide (soit unimodal) de ses extrémités nord et sud à équatorial (soit bimodal) en son centre.

Les procédures statistiques de détection des ruptures dans les séries chronologiques de leurs débits permettent d'étudier leurs tendances et de repérer les épisodes humides et secs. Le fait marquant de ce siècle est l'importante et persistante phase d'écoulement déficitaire enregistrée depuis 1971 et qui s'est accentuée à partir de 1982. Leurs écoulements ont baissé en deçà de leur moyenne interannuelle plus ou moins rapidement et intensément suivant leur position géographique. Un gradient de cette baisse a pu être tracé suivant un axe nord-sud de Bangui à Brazzaville (fig. 1). On y constate une nette diminution des régimes s'accroissant du sud au nord, conséquence directe du déficit pluviométrique qui a affecté les régions soudano-sahéliennes.

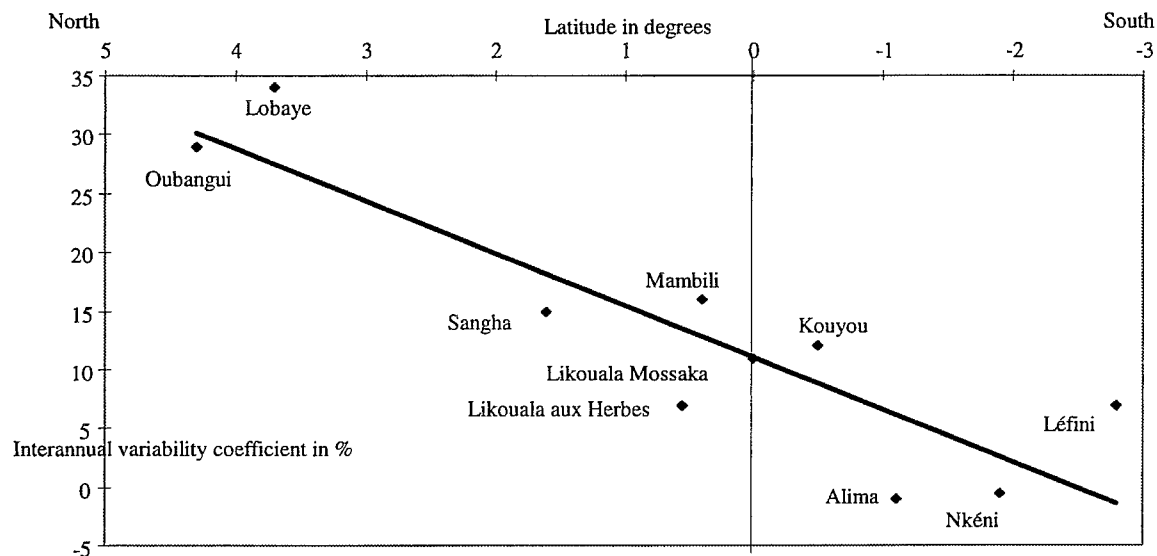

Figure 1 : Gradient de la diminution des écoulements des affluents de rive droite (période 1987-93 / 1953-93)

Figure 1 : Gradient of the decrease of the right bank tributaries runoffs (period 1987-93 / 1953-93)

Après une grande régularité interannuelle durant la première moitié du siècle, la diminution des écoulements enregistrée sur le Congo-Zaire depuis 1971 est cependant à nuancer. Durant la décennie 1970, on assiste en fait à leur retour à la normale après les années 60 fortement excédentaires (fig.2a). La baisse significative de son régime ne prend effet qu'au début des années 80 et se poursuit de nos jours avec une diminution de 10% de son module interannuel. Cette baisse est semblable pour les débits de crue et d'étiage.

Par contre, pendant cette période, les régimes des affluents rive droite ont été modifiés différemment. Ainsi, l'Oubangui qui représente la moitié de ces apports a vu son module interannuel baisser de 30% (fig.2b) mais ses étiages ont été bien plus affectés (-50%) que ses crues (-25%). La réduction de ces dernières est à l'origine de l'écroulement de la principale crue du fleuve en décembre. La baisse importante et persistante d'hydraulicité de l'Oubangui est à prendre en compte alors que l'on évoque à nouveau sa possible liaison avec le Chari par la construction d'un canal, dans le but d'alimenter le lac Tchad.

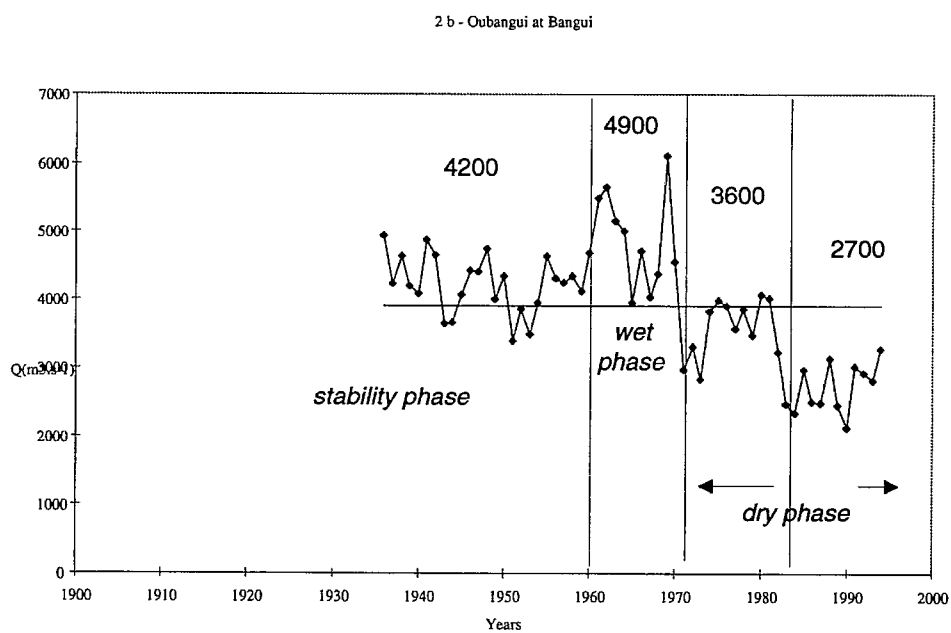
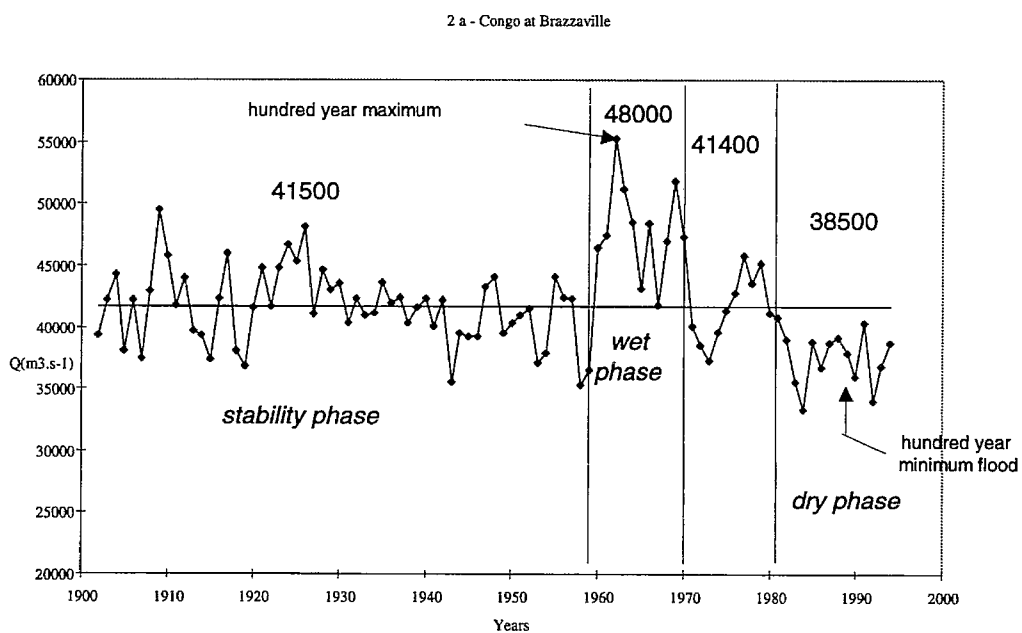

Figure 2 : Evolution à long terme des débits annuels
 Figure 2 : Long terme evolution of annual discharge

Synthèses régionales des régimes hydrologiques : approche QdF et régionalisation

Regimes synthesis, modelization and display : QdF approaches and regionalization

G. Galéa, C. Prudhomme

1 Introduction

La gestion de la ressource en eau nécessite une bonne connaissance des régimes hydrologiques des bassins versants, plus particulièrement en période critique de basses eaux (*étiage*) ou de hautes eaux (*crue*), mais elle est rendue particulièrement difficile par la variabilité spatio-temporelle des écoulements observés. Parmi les modèles hydrologiques, les modèles conceptuels permettent de rendre compte de divers régimes observés, mais ils sont souvent difficiles à utiliser hors de leur bassin versant de calage. De plus, dès qu'ils sont quelque peu perfectionnés ou distribués, ils deviennent trop complexes et relativement lourds à mettre en oeuvre pour être facilement utilisés par les aménageurs. Il est donc nécessaire de développer de manière complémentaire des outils plus simples de mise en oeuvre, tant au plan local que régional, et d'un coût économique moindre, pour répondre à certains objectifs de gestion ne nécessitant pas forcément une modélisation lourde. L'hydrologie synthétique et les modèles de synthèse permettent d'apporter une réponse dans ce sens.

Classiquement représentés par l'hydrologie statistique, les modèles de synthèse décrivent le régime hydrologique en termes probabilistes, le plus souvent ne s'intéressant qu'à un seul type de variable (*débit de pointe QIX ou débit journalier QJX*). Or, il est clair que la complexité et la richesse du régime hydrologique liées aux observations de débit ne peuvent être synthétisées qu'en prenant en compte la variabilité temporelle des débits, au risque sinon qu'une partie de l'information ne soit perdue (Oberlin et al., 1989 ; Oberlin, 1992). La dimension de temps ne peut être négligée, et il apparaît donc fondamental d'introduire cette notion de durée dans les modèles de synthèse pour satisfaire au concept de représentativité du régime hydrologique d'un bassin versant.

Une constatation générale (Prudhomme, 1995) est que la littérature scientifique internationale montre peu de modèles synthétiques régionaux traitant des débits-volumesⁱ (*moyens*) et des débits-seuilsⁱⁱ selon une approche multidurées et multifréquences des crues (Galéa et prudhomme, 1996). On peut citer les travaux de Balocki et Burges (1994) qui s'apparentent un peu à cette démarche.

Pour éviter toute confusion, il est utile de préciser dès à présent que les modèles de synthèse QdF de référence, des régimes d'écoulement en crue des bassins versants, se différencient dans leur conception des modèles classiquement utilisés en hydrologie régionale. Ces derniers, établis à partir d'une synthèse de l'information disponible (*pluie, débit, etc...*) dans un espace géographique donné (*territoire, bassin hydrographique, région, etc...*), ont en général une représentativité exclusivement liée à cet espace géographique. Le modèle de synthèse QdF quant à lui est établi à partir des seules observations (*pluie, débit*) d'un bassin versant particulièrement choisi et représentatif d'une typologie des régimes d'écoulement en crue. Ces modèles de synthèse QdF ont de ce fait une large représentativité spatiale, tant au niveau national qu'au niveau international (*comme l'ont montrées les nombreuses collaborations au sein du réseau UNESCO/FRIEND*).

ⁱ VCXd : débit-Volume (*moyen*) Caractéristique sur une durée continue d, maXimal dans la saison.

ⁱⁱ QCXd : débit-seuil (Q) Caractéristique continûment dépassé sur la durée d, maXimal dans la saison.

2 Présentation des modèles de synthèse QdF

2.1 Localisation des bassins versants de référence

La figure 1 permet de localiser les bassins versants de référence dont sont issus les trois modèles de synthèse QdF : Le modèle de FLORAC tire son nom du bassin versant de la Mimente à FLORAC ($S=125 \text{ km}^2$) situé en Lozère, dans le Sud des Cévennes. Le modèle de VANDENESSE a été calé sur le bassin versant de la Dragne à VANDENESSE ($S=115 \text{ km}^2$) situé dans la Nièvre (région Bourgogne). Le modèle de SOYANS a été calé sur le bassin versant du Roubion à SOYANS ($S=186 \text{ km}^2$), situé dans le département de la Drôme.

2.2 Typologie des régimes de crue

Chaque modèle QdF de référence traduit une typologie des régimes d'écoulement. Ainsi VANDENESSE permettra de représenter le régime hydrologique en crue de bassins versants dont l'écoulement est soutenu (*nappe, fonte de neige par ex.*) et dont les crues plutôt volumineuses sont peu rapides. En général, il est bien représenté en climat océanique (*pluie de longue durée et peu intense*). Les bassins versants aux crues rapides et violentes (*fort gradex pluviométrique en général*) seront représentés par les modèles de FLORAC et SOYANS. Ainsi FLORAC (*SOYANS dans une moindre mesure*) permet de typer le comportement en crue des bassins versants méditerranéens. Le modèle de SOYANS traduit surtout l'écoulement de bassins versants imperméables. Pour ce qui concerne FLORAC, les crues sont moins pointues et moins volumineuses (*effet de stockage par la végétation par ex., etc...*) que pour SOYANS, elles s'inscrivent davantage dans la durée (*restitution...*).



Figure 1 : Localisation des bassins de référence
Figure 1 : Référence basins localisation

2.3 Analyse probabiliste, courbes débit-durée-fréquence

La technique d'échantillonnage (Lang, 1995) relève de l'extraction des chroniques d'observation (*débit, pluie*) de valeurs maximales indépendantes supérieures à un seuil donné. La loi exponentielle adaptée aux valeurs supérieures à un seuil est privilégiée (Galéa et Prudhomme, 1996) pour représenter les distributions théoriques des échantillons de variables de différentes durées (d) constitués : VCXd et QCXd pour les débits, PXd pour les pluies.

Pour les fréquences observables ($T \leq 20 \text{ ans}$), si l'on désigne par Q le débit caractéristique en VCXd ou QCXd, les quantiles théoriques peuvent être déduits de l'équation (1) ci-après.

$$Q(T, d) = A_q(d) \cdot \ln T + B(d) \quad (1)$$

où $A_q(d)$ est le gradex des débits pour une durée (d) donnée et $B(d)$ le paramètre de position de la loi pour d donnée, définis par:

$$A_q(d) = m - Q_{n_s}$$

$$B(d) = Q_{n_s} + A_q(d) \cdot \ln\left(\frac{n_s}{n_a}\right)$$

où n_s est le nombre de valeurs de l'échantillon et $m =$ moyenne des débits caractéristiques de crue ($Q_1, Q_2 \dots Q_{n_s}$) de durée d donnée, Q_{n_s} étant le plus petit.

Au delà, pour des fréquences moyennement rares à rares ($20 < T(an) \leq 1000$), on considère que :

◆ pour ce qui concerne les débits-volumes (VCXd) et pour $d \geq D^{iii}/2$ (Jin et Galéa, 1990), la forme théorique (1) peut être extrapolée par la forme (2) dite esthétique du gradex des pluies maximales (Michel, 1982) :

$$Q(T, d) = Q(T_g, d) + A_p(d) \cdot \ln\left(1 + \frac{A_q(d)}{A_p(d)} \cdot \frac{T - T_g}{T_g}\right) \quad (2)$$

où $A_p(d)$ et $A_q(d)$ représentent respectivement le gradex des pluies maximales $PX(d)$ et le gradex des débits maximaux (VCXd) de durée d , T_g la période de retour correspondant au seuil d'extrapolation (en général $T_g = 10$ ans) et $Q(T_g, d)$ le quantile déduit de la forme (1) pour $T = T_g$.

Cette forme (2) tend asymptotiquement vers le gradex des pluies maximales, et ce d'autant plus rapidement que l'indice de saturation du sol ($A_q(d)/A_p(d)$) est proche de 1. Ceci relativise l'incidence du seuil d'extrapolation ($T_g = 10$ ans) sur les quantiles de crue rares.

Margoum (1992), lors de ses travaux sur la méthode d'extrapolation AGREGEE, a généralisé la formulation précédente (2) à toute loi des pluies maximales non strictement exponentielle, pour une durée d ($d \geq D/2$) donnée l'équation est la suivante (3) :

$$Q(T) = Q(T_g) + \frac{A_e}{K_p - K_q} \cdot \left(K_p \cdot \ln \frac{T + K_p}{T_g + K_p} - K_q \cdot \ln \frac{T + K_q}{T_g + K_q} \right) \quad (3)$$

avec :

$$K_p = \left(\frac{A_e}{A_{pg}} - 1 \right) \cdot T_g \quad \text{et} \quad K_q = \left(\frac{A_{pg}}{A_{qg}} - 1 \right) \cdot T_g$$

où $A_e = \lim_{T \rightarrow +\infty} A_p(T)$, avec $A_p(T) = dP/d\ln(T)$, pseudo-gradex des pluies maximales

A_{pg} et A_{qg} , respectivement pseudo-gradex des pluies et des débits pour $T = T_g$ (seuil d'extrapolation).

On notera que si $A_e = A_{pg} = A_p$ (loi des pluies à gradex constant, type exponentielle), on retrouve bien à partir de (3) la forme esthétique (2).

Les deux branches de distribution, liées aux débits ($T \leq T_g$) et aux pluies maximales ($T > T_g$), peuvent être rassemblées en une seule formulation (4) grâce à un mélange de deux lois exponentielles (Margoum, 1992) valable quelle que soit la période de retour (T).

$$\theta \exp\left(-\frac{Q(T) - X_0}{A_p}\right) + (1 - \theta) \exp\left(-\frac{Q(T) - X_0}{A_q}\right) = \frac{1}{T} \quad (4)$$

avec :

θ , le paramètre de pondération entre domaine observable et domaine d'extrapolation où A_p et A_q représentent les pseudo-gradex (ou gradex) respectivement liés à la distribution des pluies et des débits observés.

X_0 , le paramètre de position de la loi des débits

◆ pour $d = 1s$ (instantané), l'extrapolation de la forme théorique calée sur les observations (1) peut être obtenue à partir de la relation (Colin et al., 1977) ci-après (5).

$$QIX(T) = \lambda(C_q, C_p, T) \cdot \bar{r} \cdot Q(T, d) \quad (5)$$

où

$QIX(T)$ est le débit instantané maximal de période moyenne de retour T ($20 < T(an) \leq 1000$), de même période que le quantile de débit-volume $Q(T, d)$. Ce quantile de débit volume peut être défini au mieux pour la valeur de $d = D$, sinon pour $D/2 \leq d \leq 5D$ (Jin et Galéa, 1990).

\bar{r} est la moyenne de l'échantillon $r = QIX/VCXd$, où QIX et $VCXd$ sont des valeurs de même rang des échantillons en QIX et $VCXd$ constitués.

λ (coefficient correcteur, dans la mesure où \bar{r} ignore que $r = QIX/VCXd$ varie avec la période de retour) dépend du couple de lois suivies par $VCXd$ et r ($VCXd$ et r doivent être des variables indépendantes), et pour un tel

ⁱⁱⁱ D est la durée caractéristique de crue du bassin versant (Fig. 3), c'est la valeur de la médiane conditionnelle des ds pour la valeur du débit instantané maximal annuel décennal ($QIXA10$).

couple de lois λ dépend du coefficient de variation de VCXd (C_q), du coefficient de variation de r (C_r) et de la période moyenne de retour (T). Pour $C_r \leq 0.1$, on peut considérer que $\lambda(C_q, C_r, T) = 1$

Pour faciliter cette correction de \bar{r} , Colin et al. (1977) ont simulé les intégrales issues des produits de convolution induits par $r = QIX/VCXd$ et on peut lire λ sur des abaques. On peut se passer des abaques donnant λ et intégrer à chaque fois la distribution "produit" de r et VCXd à partir de $F(r)$ et $F(VCXd)$, notamment dans le cas (*non traité par Colin et al., 1977*) où les deux variables r et VCXd sont liées, comme le propose le logiciel AGREGEE. Pour $D/2 \leq d \leq 5D$, la relation (6) est utilisable depuis les fréquences observables jusqu'aux fréquences rares (Prudhomme, 1995), $F_2(VCXd)$ étant représentée par la loi de distribution (4).

$$F(QIX) = \int_{\Delta} \int_{\Delta} f_1(r) \cdot f_2(VCXd) \cdot [1 + \rho(F_1(r); F_2(VCXd))] \cdot dr \cdot dVCXd \quad (6)$$

♦ pour ce qui concerne l'extrapolation des débits-seuils ($QCXd$), elle relève de la méthode empirique dite de "l'analogie statistique" entre les distributions de VCXd et QCXd (Galéa et Prudhomme, 1994a,b). Les résultats sont cohérents avec ceux obtenus par l'approche théorique du modèle AGREGEE (Prudhomme, 1995), plus précisément à partir de la loi produit (7) analogue à la précédente (où $r_{QCXd} = QCXd/VCXd$)

$$F(QCXd) = \int_{\Delta} \int_{\Delta} f_1(r_{QCXd}) \cdot f_2(VCXd) \cdot [1 + \rho(F_1(r_{QCXd}); F_2(VCXd))] \cdot dr_{QCXd} \cdot dVCXd \quad (7)$$

Cette loi de distribution des débits-seuils de durée d, déduite du produit de lois des débits-volumes et des coefficients de pointe (r_{QCXd}), vérifie la distribution expérimentale des QCXd et est utilisable pour toutes les périodes de retour.

Les courbes débit-durée-fréquence (notées courbes QdF), déduites de l'analyse probabiliste précédente des événements les plus forts (VCXd ou QCXd), synthétisent la dualité existant entre la variabilité temporelle des débits et leur stabilité dans le temps, autrement dit la notion de régime.

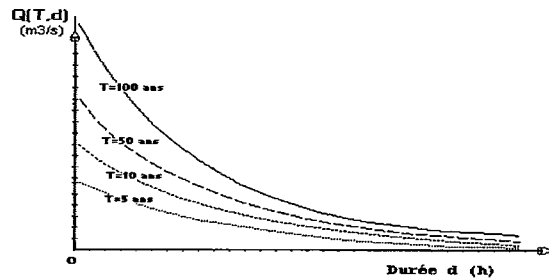

Figure 2 : Courbes débit-durée-fréquence
Figure 2 : QdF-curves

2.4 Dimension spatiale des courbes QdF

Grâce à une normalisation adéquate des courbes QdF (Fig. 2) des bassins versants de référence, on a pu établir des abaques adimensionnels représentatifs des typologies d'écoulement en crue des bassins versants. Deux normes (débit et durée), marqueurs du régime hydrologique local, ont été choisies : le débit instantané maximal annuel décennal ($QIXA10$) et la durée caractéristique de crue du bassin versant (D). Le $QIXA10$ renseigne sur la fonction de production du bassin, y compris pour les événement moyennement rares à rares liés au gradex des pluies maximales ; D , par sa définition même (Fig. 3), permet d'avoir une idée de la dynamique des crues du bassin versant et intègre donc des informations sur la fonction de transfert du bassin versant.

En l'absence d'information hydrométrique, il est possible d'estimer la durée caractéristique de crue \hat{D} (méthode SOCOSE) du bassin versant ainsi que $QIXA10$ (méthode CRUPEDIX) à partir de diverses caractéristiques morphoclimatiques (CTGREF, 1980, Cemagref, 1989).

$$\ln(\hat{D}) = -0.69 + 0.32 \cdot \ln(S) + 2.2 \cdot \sqrt{\frac{PA}{PJXA10 \cdot TA}} \tag{8}$$

- avec S : Superficie du bassin (km²)
 PA : Pluie annuelle, moyenne inter-annuelle (mm)
 PJXA10 : Pluie journalière maximale annuelle décennale du bassin (mm)
 TA : Température annuelle, moyenne inter-annuelle, réduite au niveau de la mer (°C)

$$QIXA10 = S^{0.8} \cdot \left(\frac{PJXA10}{80}\right)^2 \cdot R \tag{9}$$

- avec S : Superficie du bassin versant (km²)
 PJXA10 : Pluie journalière maximale annuelle décennale du bassin (mm)
 R : Coefficient régional

Ces méthodes dites sommaires sont peu précises, l'intervalle de confiance à 70% est $[\hat{D}/2 \leq D \leq 2\hat{D}]$, l'imprécision étant du même ordre de grandeur pour QIXA10.

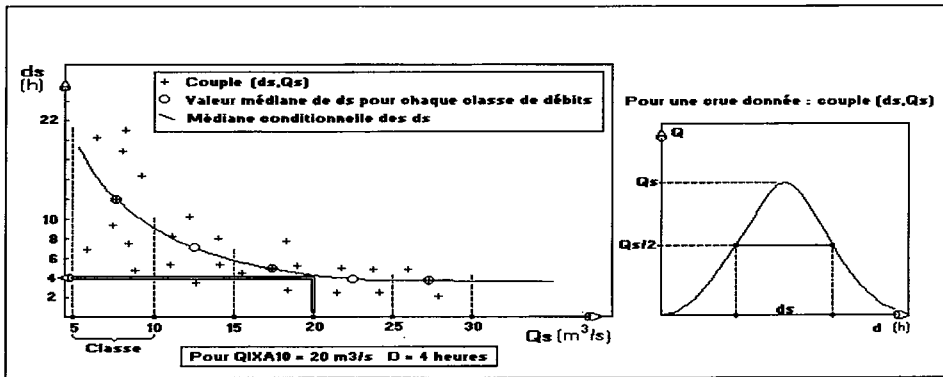

Figure 3 : Définition de la durée caractéristique de crue D (CTGREF, 1980-1982)

Figure 3 : D determination (CTGREF, 1980-1982)

2.5 Présentation formelle

S'inspirant des relations Intensité-durée-Fréquence classiquement utilisées en pluviométrie (Grissollet, 1962) un formalisme mathématique a permis d'établir pour chaque abaque normé un modèle QdF de référence.

Pour $0.5 \leq T(\text{an}) \leq 20$, généralisation (10) d'une loi exponentielle (I) avec d/D et QIXA10 (d et D exprimées en heure, ou avec la même unité).

$$Q(T, d) = (A \cdot \ln(T) + B) \cdot QIXA10 \tag{10}$$

$$A = \frac{I}{X_1 \cdot \frac{d}{D} + X_2} + X_3$$

avec

$$B = \frac{I}{X_4 \cdot \frac{d}{D} + X_5} + X_6$$

Pour les fréquences rares $20 < T(\text{an}) \leq 1000$, généralisation (11) de la forme d'extrapolation esthétique (2) des débits par le gradex de pluies maximales (Michel, 1982) avec d/D et QIXA10.

$$Q(T, d) = Q(10, d) + [C \cdot \ln(1 + \frac{A}{C} \cdot \frac{T-10}{10})] \cdot QIXA10 \tag{11}$$

où $Q(10, d)$ est obtenu par la formule (10) et où C représente le gradex implicite (normé) des pluies maximales.

$$C = \frac{I}{X_7 \cdot \frac{d}{D} + X_8} + X_9$$

Les paramètres X_i relatifs à chacun des trois modèles QdF (en VCXd ou QCXd) sont présentés au tableau 1 ci-après.

Pour plus de précision sur les modèles de synthèse QdF en QCXd, notamment pour ce qui concerne les extrapolations des débits-seuils aux fréquences rares, on se reportera aux travaux de Galéa et Prudhomme (1994a,b).

Tableau 1 : Paramètres des modèles de synthèse QdF de référence

Table 1 : Set of QdF models parameters

Modèle QdF	PARAMETRES X_i								
	X1	X2	X3	X4	X5	X6	X7	X8	X9
Vandenesse									
VCXd	2.635	6.19	0.016	1.045	2.385	0.172	1.083	1.750	0.000
QCXd	3.970	6.48	0.010	1.910	1.910	0.097	3.674	1.774	0.013
Florac									
VCXd	1.12	3.56	0.00	0.95	3.18	0.039	1.56	1.91	0.085
QCXd	3.05	3.53	0.00	2.13	2.96	0.010	2.78	1.77	0.040
Soyans									
VCXd	0.87	4.60	0.00	1.07	2.50	0.099	0.569	0.69	0.046
QCXd	2.57	4.86	0.00	2.10	2.10	0.05	1.49	0.66	0.017

Prudhomme et Lang (1994) ont établi à partir de l'expression précédente (4) un modèle continu (12) avec la durée d et la période moyenne de retour T qui admet tout type de loi (débit, pluie) non strictement exponentielles.

La formulation du modèle QdF (en VCXd) établie est la suivante :

$$\underbrace{\theta \cdot \exp\left(-\frac{Q(T)/QIXA10 - X_0/QIXA10}{A_p/QIXA10}\right)}_{\text{branche extrapolée}} + \underbrace{(1-\theta) \cdot \exp\left(-\frac{Q(T)/QIXA10 - X_0/QIXA10}{A_q/QIXA10}\right)}_{\text{branche observée}} = \frac{1}{T} \quad (12)$$

avec

θ indépendant de d

$$A_q/QIXA10 = A_{qn} = \frac{1}{x_2 + y_2 \cdot d/D} + z_2 \quad X_0/QIXA10 = X_{0n} = \frac{1}{x_3 + y_3 \cdot d/D}$$

et $A_p/QIXA10 = A_{pn} = \frac{1}{x_4 + y_4 \cdot d/D}$

Les paramètres calés pour les trois modèles QdF de référence sont les suivants (Tab. 2)

Tableau 2 : Paramètres des modèles QdF en débit-volume (VCXd) selon AGREGEE

Table 2 : Set of QdF models parameters in maximal average flow (VCXd), as AGREGEE

Modèle	θ	A_{qn}			X_{0n}		A_{pn}	
		x_2	y_2	z_2	x_3	y_3	x_4	y_4
Vandenesse	0.093	2.40	2.315	0.20	0.80	2.18	1.71	7.46
Florac	0.093	0.95	2.80	0.05	0.65	1.73	0.80	4.40
Soyans	0.043	3.85	3.00	0.12	0.27	0.86	1.35	4.70

2.6 Choix d'un modèle QdF, représentativité pour le site étudié

Le choix d'un modèle QdF de référence (Prudhomme, 1995), représentatif de l'écoulement d'un site, nécessite de considérer à la fois le gradex des pluies maximales ($A_p(d)$), qui renseigne sur le régime pluviométrique (*simple influence de type océanique, continentale ou méditerranéenne, ou influence complexe*), et les caractéristiques locales D et QIXA10, marqueurs du régime des crues.

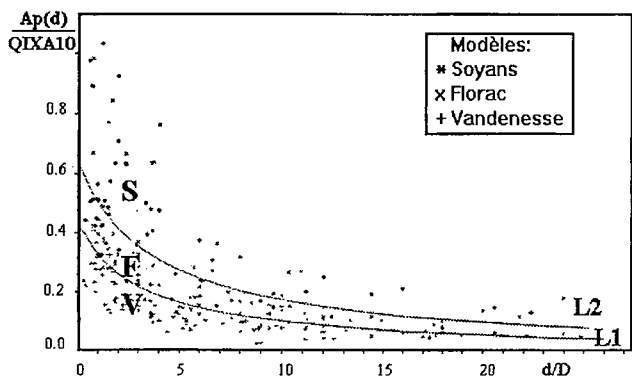

Figure 4 : Critère de choix des modèles QdF

Figure 4 : Choice of QdF models

A partir de la représentation (Fig.4) de $A_p(d)/QIXA10$ en fonction de d/D , il est possible de préciser les limites de validité des modèles de Vandenesse, Florac et Soyans

Le domaine d'adéquation de Florac est intermédiaire entre celui de Vandenesse et celui de Soyans. Les équations des limites L_1 et L_2 , permettant de séparer les trois domaines, sont les suivantes :

- limite (L_1) entre les modèles de Vandenesse et de Florac (13)

$$\frac{A_p(d)}{QIXA10} = \frac{1}{0.768 \cdot \frac{d}{D} + 2.332} \equiv L_1 \quad (13)$$

- limite (L_2) entre les modèles de Florac et de Soyans (14)

$$\frac{A_p(d)}{QIXA10} = \frac{1}{0.419 \cdot \frac{d}{D} + 1.580} \equiv L_2 \quad (14)$$

Selon que la valeur de L_0 ($A_p(d)/QIXA10$) est plus petite que L_1 , comprise entre L_1 et L_2 , ou plus grande que L_2 , le choix du modèle QdF portera respectivement sur Vandenesse, Florac ou Soyans.

3 Validation des modèles de synthèse, exemple d'application à la régionalisation des régimes de crue du bassin de la Loire (S:117 000 km²)

3.1 Validation des modèles de synthèse QdF

Les modèles de synthèse QdF ont fait l'objet de tests de validation sur un grand nombre de bassins versants en France et de manière générale en Europe (*Espagne, Italie, Roumanie, Suisse, etc...*, voir par exemple Galéa & Schuitema, 1989, Galéa & Prudhomme, 1993, 1994a, b ; Prudhomme, 1995 ; Oancea et al., 1994 ; Adler & Galéa, 1996, etc...) de taille très variable, allant de quelques ares à plusieurs milliers de km². Les quantiles de crue estimés concernent des durées (d) depuis l'instantané jusqu'à 30 jours ($1s \leq d \leq 30j$) et des périodes moyennes de retour (T) allant de deux fois par an jusqu'à mille ans ($0.5 \leq T(an) \leq 1000$).

A titre d'exemple, nous présentons ci-après (Fig. 5) les résultats de la modélisation synthétique (Sourisseau et Galéa, 1996), à partir du modèle de Vandenesse, du régime des crues du bassin versant

de la Vénoge à ECUBLENS, situé dans le canton de VAUD en SUISSE, de descripteurs locaux: QIXA10=71.4 m³/s et D=29.1 h. Ces résultats sont cohérents avec ceux déduits de l'analyse probabiliste des observations et des extrapolations.

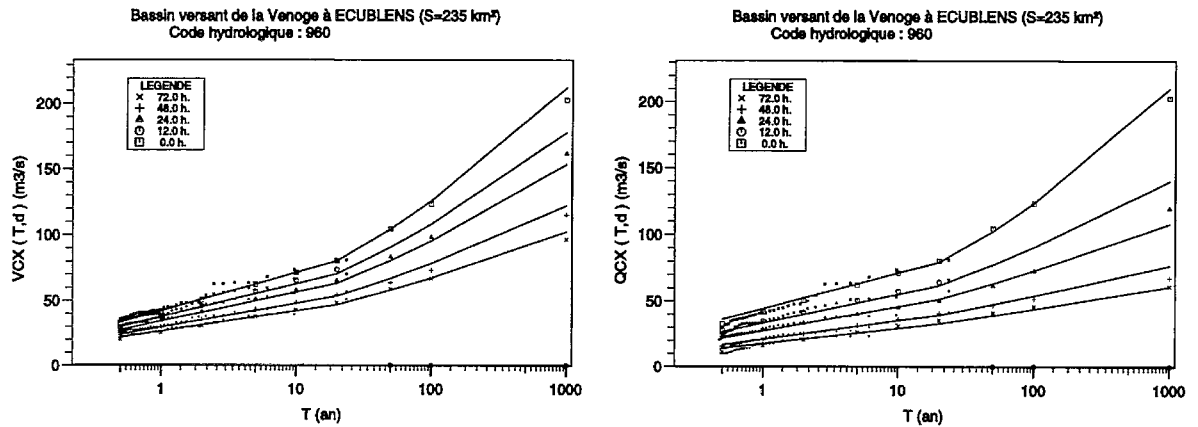

Légende : Petits symboles = valeurs échantillonnées (VCXd, QCXd) sur les observations hydrométriques,
Gros symboles = quantiles théoriques (analyse probabiliste),
Courbes = fonctions de distribution données par le modèle de synthèse QdF de Vandenesse.

Figure 5 : Validation du modèle de VANDENESSE en VCXd ou QCXd
Figure 5 : Validation of Vandenesse model in VCXd or QCXd

Ces modèles en débit seuil (QCXd) permettent de définir des Hydrogrammes Synthétiques MonoFréquence (HSMF) dont les volumes sont cohérents (Galéa et Prudhomme, 1994b) avec les quantiles de débit-volume de différentes durées (Fig. 6). De tels hydrogrammes sont à conseiller dans les études d'aménagement car ils intègrent la notion de régime d'écoulement (étroitement liée à la durée de vie des ouvrages), ce qui n'est pas le cas des classiques crues de projet. Dans les études de protection contre les inondations, ils constituent les entrées hydrologiques des modèles hydrauliques en régime transitoire, utilisés en prévention contre les inondations (Gilard et al., 1993).

Exemple d'HSMF (Fig. 6) : BVRE du Réal Collobrier à COLLOBRIERES (situé à l'Est de Marseille, cf. Fig. 1):
Code hydrologique : Y4615830 Modèle de synthèse QdF de référence : FLORAC
Superficie : 29,5 km² QIXA10=95.4 m³/s
Période d'observation : 1966-1991 Temps de montée de l'hydrogramme = D = 7.2 h

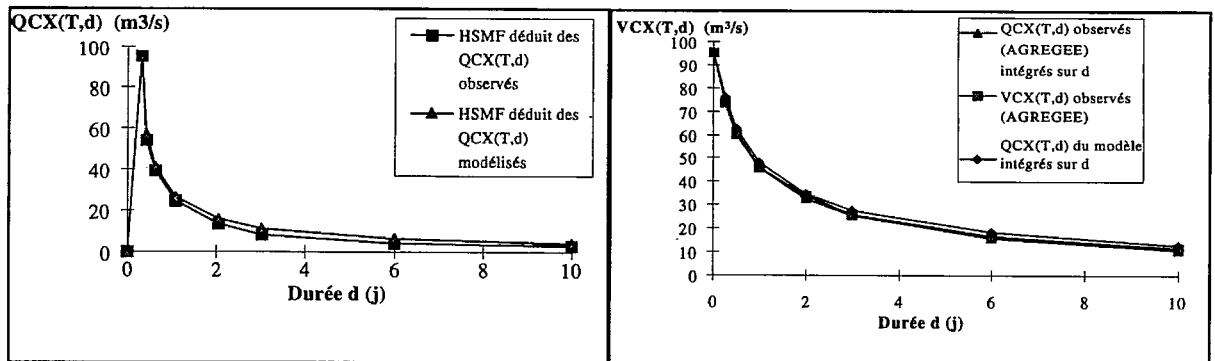

Figure 6 : HSMF décennal du Réal Collobrier, cohérence des volumes
Figure 6 : Ten years period return FMSH of Real Collobrier, maximal average flow consistency

3.2 Bassin versant de la Loire : régionalisation des régimes de crue

Dans le cadre d'une étude globale portant sur une approche écosystémique du bassin hydrographique de la Loire, l'étude hydrologique proprement dite (Sourisseau & Galéa, 1996) s'est donnée trois objectifs principaux :

- étudier la diversité des régimes hydrologiques en crue,
- proposer un outil régional permettant de restituer la diversité de ces régimes,
- faciliter l'utilisation opérationnelle de l'outil QdF.

Dans un premier temps, 76 bassins versants observés ($S \leq 3500 \text{ km}^2$), sur les 500 environ que compte le bassin hydrographique de la Loire, ont été choisis (Fig 7) en fonction de leur répartition, de leur taille, de la qualité des chroniques, etc..., afin de disposer d'un échantillon représentatif des principaux régimes observés.

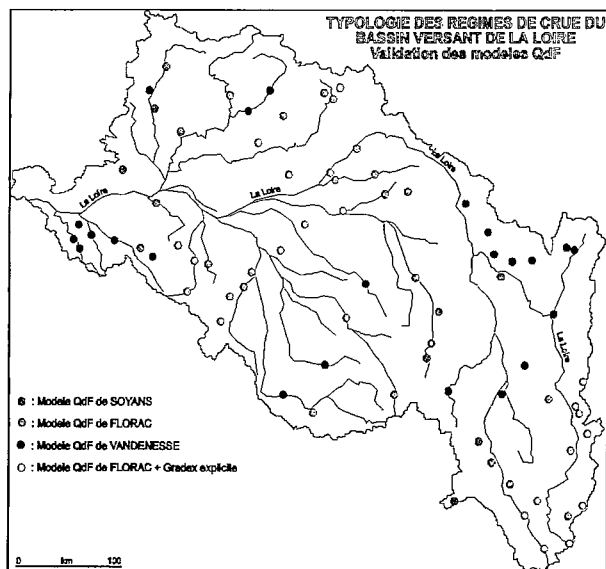

A partir des trois modèles de synthèse QdF, chacun d'eux se référant à une typologie des régimes de crue, il a été possible de simuler (cf. ex. Fig.5) l'ensemble des régimes observés (ou extrapolés) sur les 76 sites choisis. Autrement dit, au sein de chaque famille hydrologique de bassins versants, dont la typologie des crues est représentée par un modèle de synthèse QdF, il est possible de restituer à partir de ce modèle la diversité des régimes de crue observés grâce aux descripteurs locaux de régime. La carte de la figure 7 donne une représentation de la typologie, au sens des QdF, des régimes de crue observés.

Figure 7 : Bassins sélectionnés

Figure 7 : Selected basins

Les résultats (Fig 7) obtenus pour le bassin versant de la Loire confirment, comme d'autres études d'hydrologie de synthèse réalisées en France et en Europe (Prudhomme, 1995), que le choix d'un modèle de synthèse ne peut dépendre ni de la localisation géographique du bassin versant, ni de ses caractéristiques physiographiques (*géologie, occupation du sol, pédologie, climat, etc...*) mais essentiellement de la typologie de son régime d'écoulement (*combinaison résultante de l'ensemble des processus de transformation pluie-débit*).

Dans un deuxième temps, l'erreur sur les descripteurs locaux de régime, estimés selon les formulations sommaires (8) et (9), a été spatialisée à partir d'un SIG Loire. En règle générale, la démarche géostatistique concerne aussi certaines variables nécessaires aux formulations (8) et (9), comme la pluie journalière décennale (*PJXA10*). Les cartes suivantes (Fig. 8) contribuent à faciliter l'usage opérationnel des modèles de synthèse, notamment sur des bassins non observés.

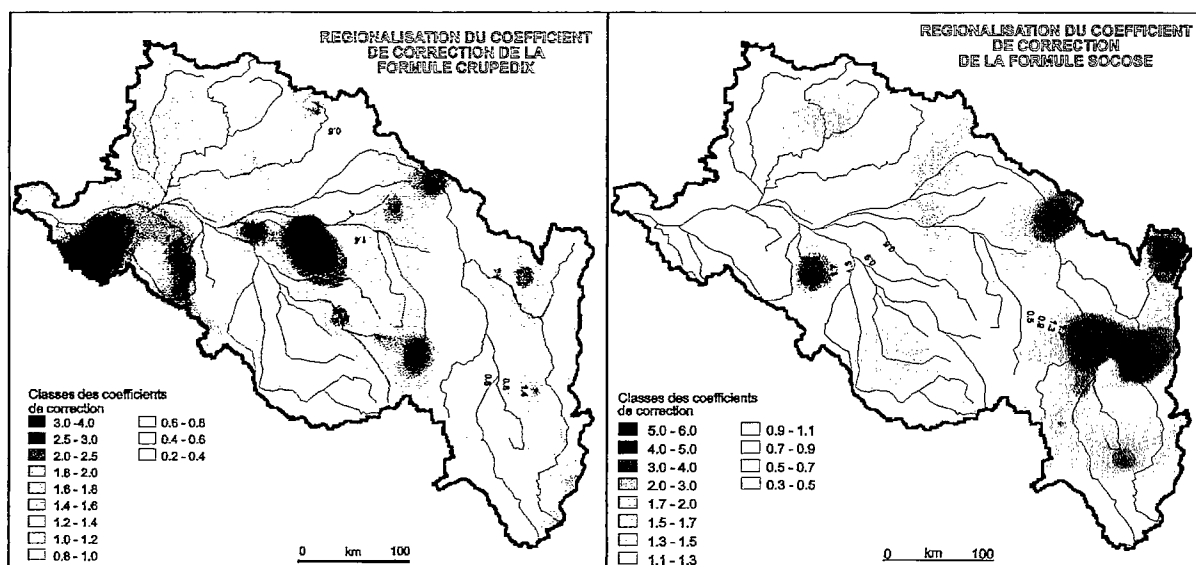

Figure 8 : Coefficient de correction de $QIXA10$ selon $CRUPEDIX$ et de D selon $SOCLOSE$
Figure 8 : Correcting factor of $CRUPEDIX$ and $SOCLOSE$ relations

En règle générale, pour ce qui concerne l'estimation des paramètres d'entrée de ces modèles (D , $QIXA10$) en l'absence d'information, l'effort est à poursuivre. En effet, les formules sommaires d'estimation (8) et (9), bien que fort utiles n'en demeurent pas moins encore trop imprécises. Prudhomme (1995) a étudié la sensibilité des quantiles de crue modélisés aux erreurs liées à l'estimation de $QIXA10$ et de D . S'il est vrai que la représentativité des résultats est essentiellement liée aux paramètres d'entrée locaux (*et au choix du modèle effectué*), cela peut être cependant nuancé. En effet, les erreurs sur les descripteurs ne vont pas toujours dans le même sens, il peut donc y avoir une certaine compensation des erreurs qui globalement permet au modèle de simuler des quantiles acceptables. Par ailleurs, les critères de choix (Galéa et Prudhomme, 1994b), qui intègrent ces descripteurs et donc l'erreur qui leur est associée, indiquent généralement le modèle donnant les résultats les plus proches du régime réel du bassin versant. Cela dit, un gain de précision ou plutôt de diversification des caractéristiques locales (D , $QIXA10$) des bassins versants est grandement souhaité, il pourrait être obtenu à partir d'une approche basée sur la typologie des régimes d'écoulement, comme cela a été commencé pour les petits bassins rapides (Galéa et Ramez, 1995).

4 Conclusion

Les exemples précédents, du bassin hydrographique de la Loire, du BVRE du Réal Collobrier et du bassin versant de la Vénoge, ont permis de montrer certains aspects opérationnels des modèles de synthèse QdF. Plus exhaustivement, ces modèles permettent aussi de dimensionner un bassin de rétention (Grand & Galéa, 1996), de préciser une réglementation, de donner des indicateurs pouvant avoir une importance écologique, ou encore de traduire certaines demandes sociales en matière de gestion intégrée (Cemagref-Lyon, 1992) des cours d'eau et de leurs bassins versants, etc.... En définitive, ces modèles opérationnels débit-durée-fréquence dits QdF, simples, robustes et faciles à mettre en oeuvre, permettent d'obtenir des résultats finalisés, intégrant la grande variabilité spatio-temporelle des débits. Le maintien dans les diverses formulations d'une structure claire, entre ce qui résulte des observations d'une part et des extrapolations d'autre part, donne la possibilité de remplacer certaines fonctions intermédiaires à validité régionale par leur valeur locale (Prudhomme, 1995). C'est le cas en général des bassins versants karstiques (*ou très perméables, cf. Fig. 7*) où il est conseillé de remplacer le gradex implicite régional C (11) par le gradex explicite de la pluie locale normé ($A_p(d)/QIXA10$), pour l'estimation des quantiles de crue de fréquences rares.

Effets d'échelle et cartographie des écoulements

Scale effects in runoff mapping

E. Leblois , E. Sauquet

1 Introduction

Within the Gewex-Rhône project, the Agence de l'Eau Rhône Méditerranée Corse (Rhône basin valley authority) requested the Cemagref Lyon, Hydrology-Hydraulic Division, the study presented thereafter. It aims at mapping runoff features (mean, high or low flow) and is supposed to achieve an evaluation of runoff according to predefined areas.

2 Study context

2.1 The Gewex-Rhône project (a french contribution to Gewex)

The Gewex-Rhône project belongs to the French contribution to GEWEX (Global Energy and Water Cycle Experiment). Its purpose is to set up a coupled atmospheric and distributed hydrologic model of the french part of the Rhône basin. A reference hydrologic study had to be done. This is part of this study.

2.2 The Rhône study area (of GIP Hydrosystèmes)

A study area is a geographic area where scientists try to coordinate their investigations to get a common understanding of it, here an hydrosystem, that is not only the river, but everything interacting with it. Thirteen study areas were set up in France, with help of GIP Hydrosystèmes^{iv}. One of these concerns the Rhône, in which researcher involved try to set up a common geographic knowledge. The synthetic description we get about rivers flows may help.

2.3 The WCP-B3 group

Hydrologists do want their observed data to be used by atmospheric scientists for atmospheric models validation. As atmospheric models turn with gridded meshes, runoff data have to be transformed from catchments to grids. For this a workgroup of World Climate Program (WCP-B3) choose a general method, taking into account the nested nature of observed discharge data. This paper aims to contribute to the same topic.

3 Data

3.1 Topographic data

For the study, Rhône basin authority put at our disposal a general digital elevation model (DEM) at 100 m resolution. We also used the general topographic coverage of the EROS Data Center (USGS),

^{iv} GIP Hydrosystèmes is a small co-operating structure of French public research institutions involved with water cycle (BRGM, Cemagref, CNRS, Ifremer, INRA, Orstom and OIEau)

available on Internet at the 30'' resolution.^v. Both were useful : one for better resolution in some difficult cases, the other one to get a topographic basis juridically easy to transfer.

Here we have an outlook of the study area, with its main parts, either subcatchments of the Rhône or Mediterranean shore.

3.2 Hydrology

3.2.1 Daily discharges

The French national data bank HYDRO was the source of most part of daily discharge data. The other part was provided from the FRIEND data base. So we obtained 324 discharge stations for the 130 000 km² study area. Catchment areas are from 50 km² and up (up to 96500 km² for the Rhône in Beaucaire). Each discharge record has at least 8 years of data.

4 Preprocessing

4.1 Topography analysis

The basin structure was summarised into a set of unit square cells flowing each one into an other, aiming at matching the existing river network and the up area of each cell. Here we have the result. The catchment area is a growing function of the grey grade. Working cell size is 1 km.

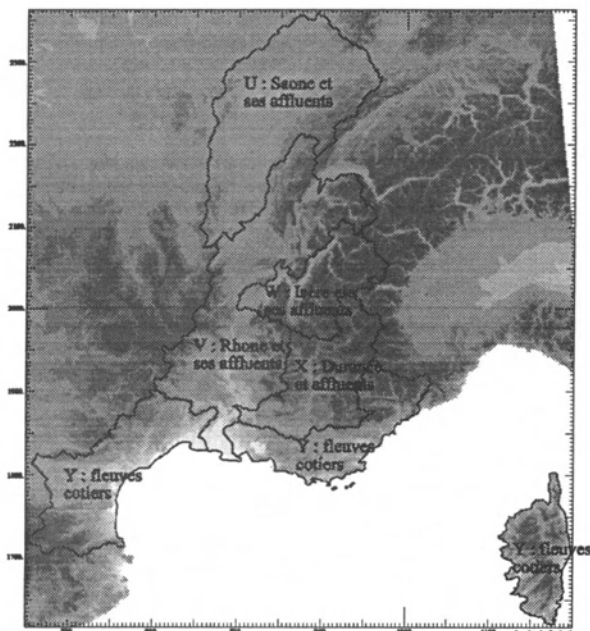

Figure 1 : Topographie et zone étudiée (Cemagref 1996 pour l'Agence de l'Eau RMC - Analyse descriptive de la ressource en eau superficielle).

Figure 1 : Study area and elevation

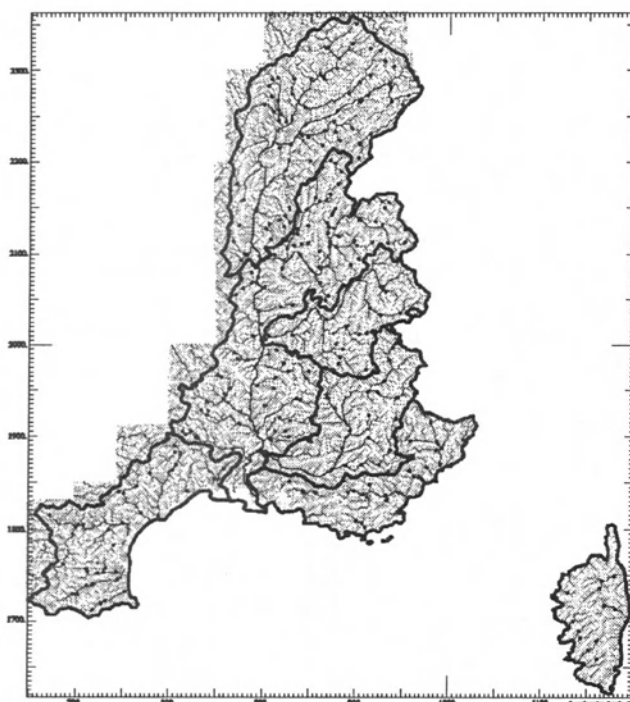

Figure 2 : Surface drainée en tout point : localisation des stations utilisées

Figure 2 : Catchment area and discharge data points

^v <http://edcwww.cr.usgs.gov/landdaac/gtopo30/gtopo30.html>

4.2 Discharge data preprocessing.

Dams and other public works were built into the Rhône basin up to the beginning of the seventies. So we used only discharge years after 1970 into analysis. We derived from discharge series the usual descriptive values for water availability, that is annual discharge QA and twelve monthly discharges QM_i . Interannual discharge \overline{QA} is the first characterization for water availability. The behaviour of median monthly discharges, with respect to month, gives a very accurate view of the saisonnal cycle. In fact, we used the position parameter of a square root normal distribution. It had to reduce the skewness of monthly flows and to get a stable estimator of the median value.

About high flow, we may consider following discharge characteristics :

<i>Discharge that is continuously overseeded for a given duration d</i>	QCX(d)
<i>Mean discharge during a given duration d</i>	VCX(d)
<i>Discharge that is overseeded within the year during a total cumulated duration d</i>	DCX(d)

The first one is related to sensitivity of human or natural environnement, so to impact questions, from positive humid areas watering to human and other's injury. The second is representative of gross water volume (once multiplied by duration) and therefore directly related to geophysics and hydraulics for resource and floodplain management. The third is the ancestor (« débits classés » following Maurice Pardé), but stays meaningful for specific questions like hydropower. Here we will use VCX that are more related to water resource considerations. We studied VCX for durations from 1 to 30 days, fitted by a traditionnal Gumbel law.

Minimum monthly flow evaluated for 5 and 10 year return period characrerized low flows.

5 Runoff mapping

5.1 Some theoretic considerations

5.1.1 Runoff generation and river discharge

Runoff as two different aspects, not to be mixed together :

- the one is a local point process, we will here say **runoff generation** (*génération d'écoulement*).
- the other one is **streamflow**, concentrated in hydrographic network, and measured at the outlet of a catchment (whatever the size of the catchment). Its measure is **discharge** (*débit*). Streamflow is an indication about the overall behaviour of the catchment.

In both cases, we may write $R = ETR + I + \Delta S + Q$, where R is rain, ETR is evapotranspiration, I is infiltration, ΔS a possible stock variation, and Q is available water « to run off ».

If we want a complete knowledge of runoff, we may start from one or the other point of view. When considering point processes, neglecting infiltration and stock variations, runoff appears to be a point value, hard to measure as a routine, but we may deduce it from rain and evapotranspiration. Such data are scarce, at least for evapotranspiration. The way we shall link evapotranspiration to deterministic factors will be determinating for the results.

If we start from streamflow, equation's terms are no more point values but volumes yielded by the general structure of the catchment. We will have to take into account the size of the catchment considering each observed streamflow. A common way to do, is to dividing discharge by area to obtain specific discharge. This allows to compare equations terms to ponctual observed values for rain or evapotranspiration. But we think that drawback is also quite serious : this way of doing may

let forget the spatial heterogeneity of processes ; it lets believe that observed discharges are comparable one another when reduced to water depth. But there is no reason that the respective parts of rain, evaporation or runoff in the balance should be the same for all catchment sizes, within a common geographic area. Further on, we will accept that the size of catchments as to be taken into account for mapping.

5.1.2 Areal runoff production

If we are concerned with a given territory (catchment or not, maybe just an administrative district), we may be interested by its *areal runoff production*. This is both areal sum of runoff generation and resulting value of streamflow across the border.

5.1.3 The RESEDA effect

RESEDA is an acronym for « Réduction Significative des Ecoulements Disponibles vers l'Aval ». It is the usual consideration that interannual specific flow seems very often to decrease as we consider growing catchments along a given river.

This is usually considered to be influenced by rain, that is less in plains, water infiltration into alluvial systems, final water use by humans, etc.

Whatever the explanation or the importance of this phenomenon, we consider that it is polluting water resources studies (mixing discharge data taken at different scale with no cautions). A consequence for us is the following : we assume that discharge data observed at a same given size of catchment are comparable. Others are not.

possible theoretic consequence

Once we have taken into account rain and other factor's spatial variation, the RESEDA effect may be related to the hydrographic structure itself. The difference observed between runoff at different scale may be related to the evapotranspiration of the alluvial system itself (where there is usually always water available). If the alluvial system evaporates more than the other parts of the catchment, there is a need for advection of corresponding energy, and atmospheric modellers will have to cope with it when downsizing.

practical consequence

If the RESEDA effect does exist within a discharge data set, it has to be able to survive within the interpolation scheme.

5.2 Practical mapping

5.2.1 Principle

Let us remember that the basin's topology has been summarized by square flowing into others. So we have a continuous map of drained area and related values for runoff.

The interpolation was made in a 3D space : X and Y are geographic location (here the French geodesic system Lambert II generalised). The third axis is the logarithm of the catchment area. A catchment with smaller area will be « lower » in the interpolation space and one with greater area will be « higher ». Thus, data from small catchments are mostly among themselves, data from bigger

catchments are mostly among themselves. However they are all in the same continuous space and in the same interpolating scheme.

5.2.2 Distance calculation

When calculating distances, we will have to balance numerically between geographic and « sizer » distances. This was done numerically giving the same importance to the maximum geographic distance and the maximum « sizer » distance. Between two catchments represented by their coordinates $(x_1, y_1, Ln(A_1))$ and $(x_2, y_2, Ln(A_2))$ the distance is as follows :

$$d^2 = (x_2 - x_1)^2 + (y_2 - y_1)^2 + \lambda \cdot (Ln(A_2) - Ln(A_1))^2 \quad \text{with}$$

$$\lambda = \lambda_0 \frac{\max_{i,j} [(x_j - x_i)^2 + (y_j - y_i)^2]}{\max_{i,j} [(Ln(A_j) - Ln(A_i))^2]}$$

λ_0 is the balancing factor between geographic distance and catchment size. We choose it equal to 1, with no special reason other than simplicity (a variographic analysis could give information on this). The ratio of maxima gives an actual value for λ , according to observed data and to the choice made for λ_0 .

6 Results

6.1 Interannual runoff

The « *écoulement interannuel* » figure shows the interannual runoff, millimeters ranges from 0 to 2000, colored from yellow to blue. Runoff is strong in mountains (Jura and Alpes) and also in Cevennes and in the Corsica Island. It is low near the Mediterranean sea, as in the upper western part of the study area and in the Rhône's Valley.

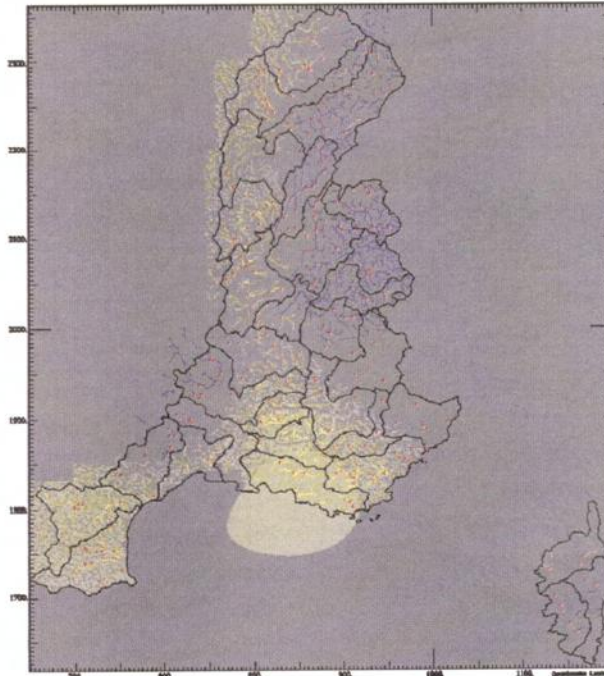
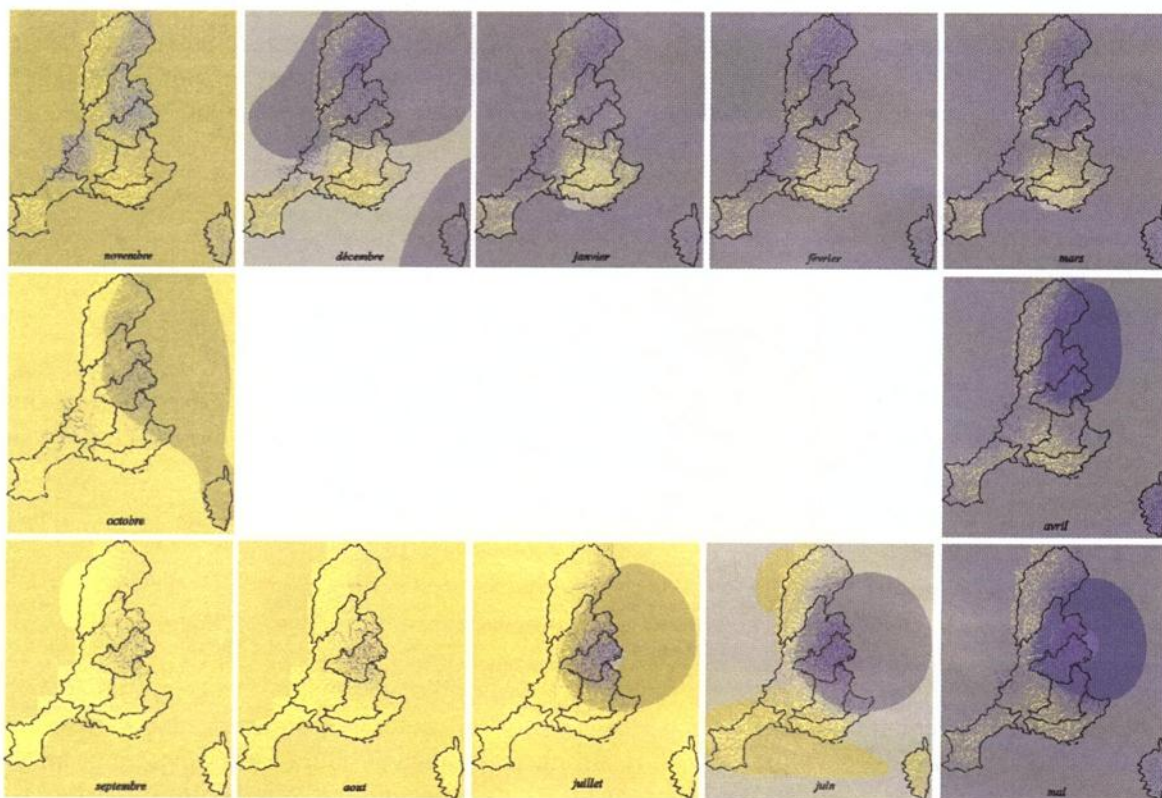

Figure 3 : *Écoulement interannuel*

Figure 3 : *Interannual runoff*

6.2 Annual cycle of monthly runoff

If we consider monthly runoff, we get a very interesting insight of the climatology of the study area :



(Scale from 0 to 200 mm as colour goes from yellow to blue).

Figure 4 : *Écoulements mensuels médians - aperçu général du cycle annuel*

Figure 4 : *Median monthly flow - annuel cycle*

In January and February, flow is very high in the Cévennes, Jura and East of the Saône River. It is noticeable in Corsica and northern Alps, but not high. This is to be related to western oceanic rains, concerning both Jura and Alps. Because of snow, flowing in the Alps is delayed.

From March onwards, a strong melting signal is observed in the Alps. Then all mountains die off progressively. The Alps are the water tower of the area. Runoff is noticeable to september, thanks to snow melting and glacierized areas contribution.

From Septembre, we may observe the start of autumn rain in the Cevennes (South wind, giving flash floods, important enough to appear here), and the progressive watering of all the area, mostly in Jura. Then the cycle naturally loops back to January.

The cycle observed here stresses on the value of Alps as a reservoir in summer. It is consistent with various well known aspects of local geography.

6.3 Areal runoff production estimation

6.3.1 Principle

The interpolation technique we used affords an estimation of runoff depth at each point of the hydrographic network. This estimation takes into account all available data, catchment's size and

geographic location. Multiplying water depth by catchments size, we get an approximate but spatially complete discharges field. Let us name this discharge field \bar{Q} .

Runoff generation is the divergency of this field : $R = \text{div}(\bar{Q})$. Numerically, we get an approximation of each cell's production. Of course, this differentiating approach enhances all biases of the underlying interpolation scheme. But cumulating all cell's production per areas of interest, this effect is hoped to be mitigated. So we get the following maps of areal runoff's estimation.

6.3.2 Areal runoff estimation at different levels of hydrographic segmentation.

Areal estimation of runoff has been derived for different levels of French hydrographic segmentation, that is hydrographic regions, sectors, sub-sectors. Discharge characteristics were median monthly runoffs, derived from median monthly discharges, and interannual runoff, derived from interannual discharge.

The next figure shows how interannual runoff production is distributed in the study area. Colours range is evaluated from -500 mm (yellow) to 2000 mm (blue) (-500, for some areas are strict consumers).

Overall production of the study area is 533 mm, that is 69,5 km³ according to a 130000 km² area.

Downsizing to hydrographic regions we observe quite a meaningful pattern : Saône area produces 576 mm, that is 17,0 km³ ; Rhône area produces 438 mm, that is 15,3 km³ ; Isère area produces 857 mm, that is 10,1 km³ ; Durance area produces 592 mm, that is 8,5 km³ ; the Mediterranean coast produces 404 mm, that is 18,4 km³

We may notice different points when checking montly values : the Rhône area is a net consumer from July to September ; the Isere area is a net producer for at least 80 mm/month from April to July.

If we further desagregate in smaller units (to sectors), we get good news and bad news. Good news are for example the behaviour of Corsica. It was first « clamped » to Mediterranean and now it takes freedom for higher values. Bad news is the behaviour of some places like southern Durance area. There lack of data (or incorrectly indentified catchment areas) shows (at least) that our whole system is very sensitive to data mistakes.

6.3.3 Areal runoff estimation per administrative or geographic units

The principle of areal runoff estimation is not limited to hydrographic sub-catchments or such pieces. Any arbitrary area like an administrative circonscription or a cell in an geographic mesh may be evaluated the same way. For example and above we took a half-degree mesh as used in the WCP-B3 group.

6.3.4 Discussion of areal runoff estimation

At the hydrographic region level, everything is fine and meets the knowledge we have about local climatology. When we desagregate, good and bad news suggest that the algorithm used may have good potentialities. But lack or erroneous data is very sensitive.

A second thing is that owing the heterogenity of each area, the procedure, as such, is just right for mean values. If we want a quantile of areal evaluation, we should first map each annual value, and then make statistics on the sample of annual areal values.

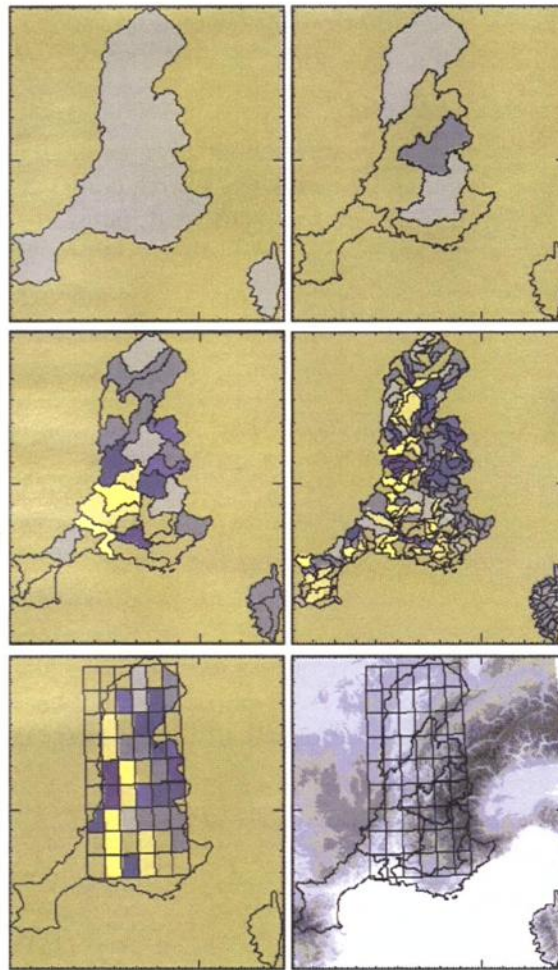

Figure 5 : Production annuelle d'écoulement par zone hydrographique ou géographique
Figure 5 : Net runoff production per hydrographic or geographic area

6.4 Other possible consequencey

6.4.1 The RESEDA effect

A starting point for our mapping scheme was to let the RESEDA effect be respected by the interpolation procedure if it is present in the available point data. So, we shall consider how the mean runoff varies with location along a given river.

First, mean runoff does vary along a river and this is an advantage to our « 3D » approach (would mean runoff be nearly stationnary along a river, simpler methods would be possible and are to be preferred).

The RESEDA effect is obvious along Var and Rhône rivers :

Isère exhibits a complicated behaviour (a strongly water-powered river...) ; in the case of the Saône, runoff is increasing downstream. Is that due to local conditions (tributaries from Jura, seepage from the aquifers ?) or pure artefact ?

We shall not conclude on reality or importance of the RESEDA effect. But we should notice that nothing in our interpolating scheme induces the variations observed here. Let us say, it is not possible to consider that runoff is constant in space, in an area with contrasted climatology as Rhône.

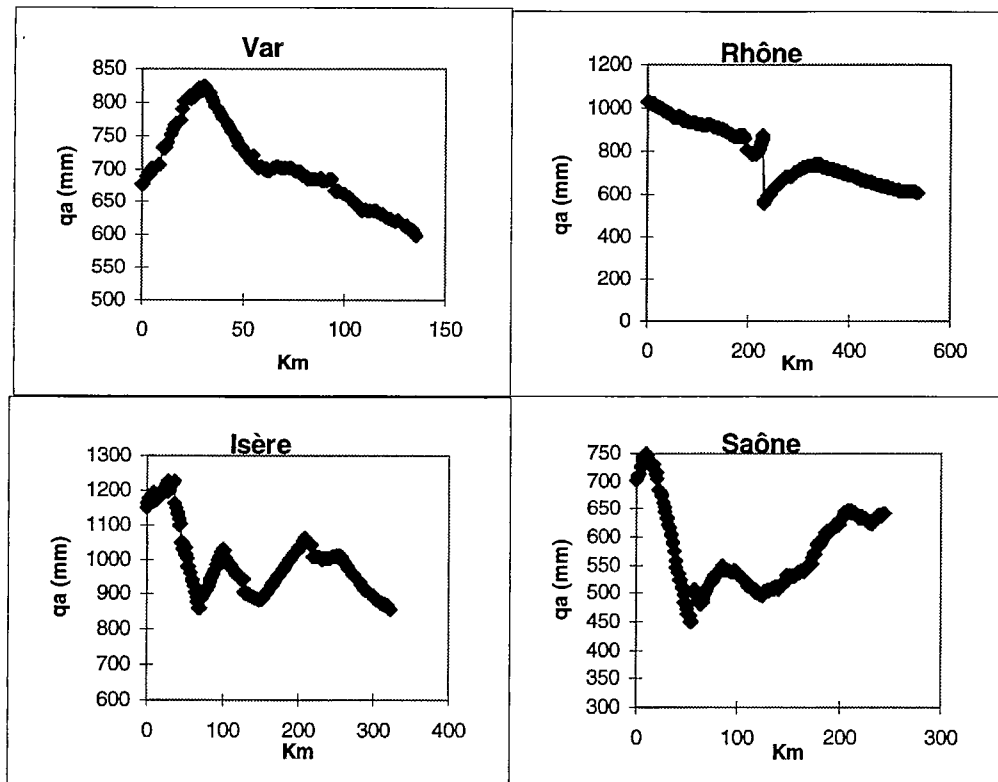

Figure 6 : *Instationnarité de runoff along a river*

Figure 6 : *Caractère non stationnaire de la lame d'eau écoulee en un point d'une rivière*

6.4.2 Runoff mapping for a given catchment size.

For this study, until now, all maps are interpolated for actual catchment size. We may also map runoff as would the catchment size be given at a fixed level within our 3D interpolating bloc.

Three such level maps are shown for catchment sizes of 100 km², 2500 km² et 62500 km².

At 100 km² level, high runoff areas are exactly the same as what can be seen on net rain maps ; so, we have a possible way to let pure streamflow data be interpreted to meet climatic data : indeed, net rain is exactly runoff out of small catchments.

At 2500 km² level, local contrasts diminish, we just see both main runoff areas that are Jura and Alpes ; the 62500 km² level is not well documented in our system. It could be interesting for consideration at a broader study zone (FRIEND Level), when many rivers of the Rhône's size will be present.

This is not exactly a cartographic generalisation. These maps are merely maps related to a given reference area, as it is usual for engineers, whose formulas may yield streamflow estimation for any location and any catchment size, whatever the local reality.

6.4.3 Uncertainty qualification

Any geostatistical mapping has a probabilistic look at nature that should enable an estimation of uncertainty to be associated to its prediction. We are aware of it, but it has not been done yet. Much theoretical work has to be done before. A part of it being how to take into account the point uncertainties (of hydrological statistics) into spatial interpolation.

We will find here an excerpt of a runoff map with associated variance. Variance is low near to data points, that is geographically near to them AND in catchments of the same magnitude.

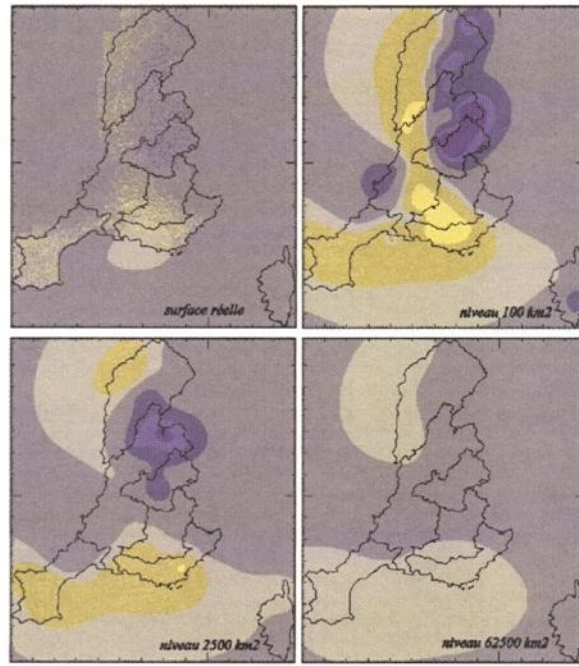

Figure 7 : Production annuelle d'écoulement selon la surface du bassin versant
 Figure 7 : Annual runoff related to a given catchment area

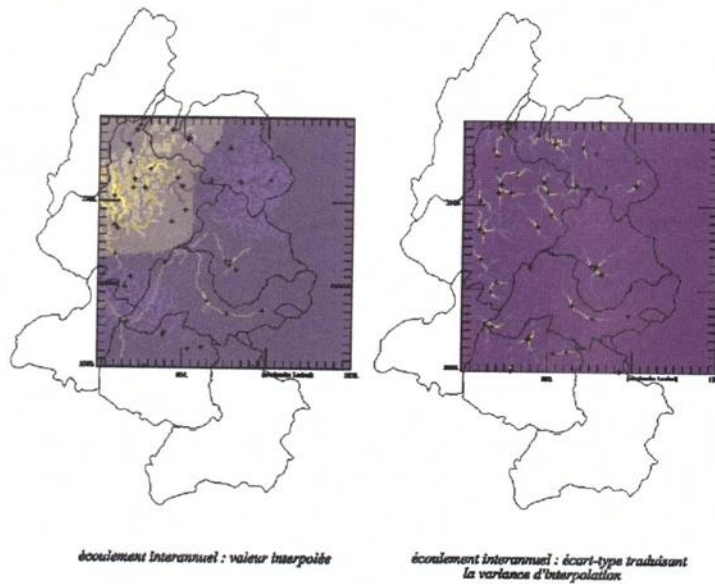

Figure 8 : Interpolation et variance d'interpolation
 Figure 8 : Interpolation and interpolation variance

7 Conclusion

The mapping technique used here seems promising. Much job is still to be done to clean up all shortcomings in it. It could be a basis for mapping runoff and streamflow features with respect to the scale of the catchments that originate the data, checking scale-related features as the RESEDA effect, deriving areal aggregates of interest to meet colleagues working in atmospheric modelling. Practical mapping seems also possible into greater areas (like FRIEND areas) or into administrative boundaries.

Regional quantification of catchment sensitivity to climate variability

La sensibilité des bassins à la variabilité du climat : quantification régionale

B. van der Wateren-de Hoog

Introduction

For water resources management, quantification of the sensitivity of the discharge of catchments to climate variability is necessary to assess water resources and to identify flood and drought prone catchments both for present and future climate conditions. Water resources are already stressed in certain parts of Europe at present. Floods and droughts can cause a lot of damage, as was experienced in Europe in recent years. Any change in climate may increase stress on water resources or cause more damage. This report summarized the development and verification of a regional model that quantifies catchment sensitivity to climate variability.

Research showed that catchment sensitivity to climate change depends on the water holding capacity of a catchment and on the climatic input to a catchment. Bultot *et al.* (1988) and Arnell (1992) used discharge models to show that catchment storage capacity is a significant factor determining the impact of climate change. Catchments with large storage capacity reacted slower to climate change than catchments with a small storage capacity. Van der Wateren-de Hoog (1995) analyzed the impact of climate variability (in the form of dry and wet periods of several years) on catchment discharge using flow duration curves. She showed that present storage in relation to catchment storage capacity is also important. As an example, catchments with nearly full or empty stores at present react nonlinear to changes in precipitation, whilst catchments with a medium fill of stores react more linear to changes in precipitation.

Development of a model to quantify catchment sensitivity to climate variability

To quantify catchment sensitivity to climate variability an annual regional model was developed based on the factors described above. In this model the present maximum reservoir storage (s_{pm}) is linked to the storage capacity (s_c) and the climatic input. s_{pm} is expressed as a fraction of s_c . This fraction is defined by the relation between s_c and the climatic input. The climatic input in the regional model is the precipitation reaching the catchment store. On an annual basis, this will be a fraction (d) of the average annual net precipitation (P_{AAN}). Hence, the regional model is defined as in the equation below, with variables expressed in mm; parameter d is dimensionless.

$$s_{pm} = s_c e^{-\left(s_c / dP_{AAN}\right)}$$

The ratio of s_{pm}/s_c defines the present catchment sensitivity to climate variability. Catchment sensitivity defined this way can easily be visualised: a catchment with a nearly empty reservoir at present can easily store more water, but cannot overcome dry conditions. Such a catchment will be drought prone and is identified by a low ratio of s_{pm}/s_c . A nearly full catchment at present cannot store much extra water and will therefore be flood prone. Such catchments are identified by a high ratio of s_{pm}/s_c (Figure 1).

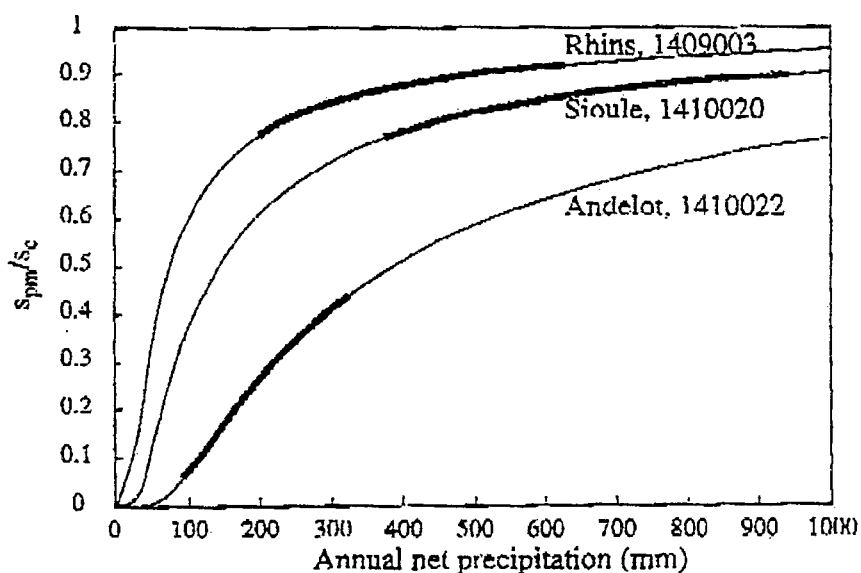

Figure 1 : Catchment sensitivity for present climate conditions (1970-1983, thick grey line) for three FRIEND catchments

Figure 1 : Sensibilité des bassins aux conditions climatiques actuelles (1970-1983, courbe en gras) pour trois bassins FRIEND

To apply the above equation s_{pm} , s_c and P_{AAN} need to be quantified. s_{pm} can be approximated by recession analysis from time series of daily discharge as described by Tallaksen (1989). For each recession period the storage at the start of the recession period can then be approximated using linear storage theory. s_{pm} is defined as the average storage plus two standard deviations from all recession periods analyzed. s_c is defined by the volumetric and geological properties of the catchment. By using linear groundwater theory s_c can be approximated with the variables: catchment slope (Sl , dimensionless), catchment shape (Re , dimensionless, Schumm, 1956), catchment recession constant (α , day^{-1}) and the catchment hydraulic conductivity and proportion of drainable aquifers (combined in K , mm day^{-1}):

$$S_c = \frac{K Sl^a}{\alpha^b Re^c}$$

The use of linear groundwater theory limits the application of the regional model to catchments with fairly homogeneous geology and not too steep slopes.

Effective precipitation P_{AAN} can simply be approximated by multiplying average annual precipitation with the runoff ratio. The model described by these equations can be regionally applied to assess catchment sensitivity by fitting the parameters a , b , c , d and K to the studied region. The variables Sl , α , Re and P_{AAN} need to be available for selected catchments.

Regional application of the developed model

The regional model was applied to 15 catchments in the Upper Loire basin, France, for which the assumptions were valid. The non-linear estimation procedure of the statistical software package CSS-statistica using the quasi-Newton method and least squares loss function was used. The model proved to be statistically sound; model variables were not correlated and residuals were normally distributed. Furthermore, the model parameters were stable (as proved with a jack-knifing test); the coefficient of determination (r^2) was 0.86. The catchment storage capacities calculated with the regional model are presented in Figure 2 and are in accordance with reported water resources in the area. The

development and application of the regional model is described in detail in Van der Wateren-de Hoog (1997a).

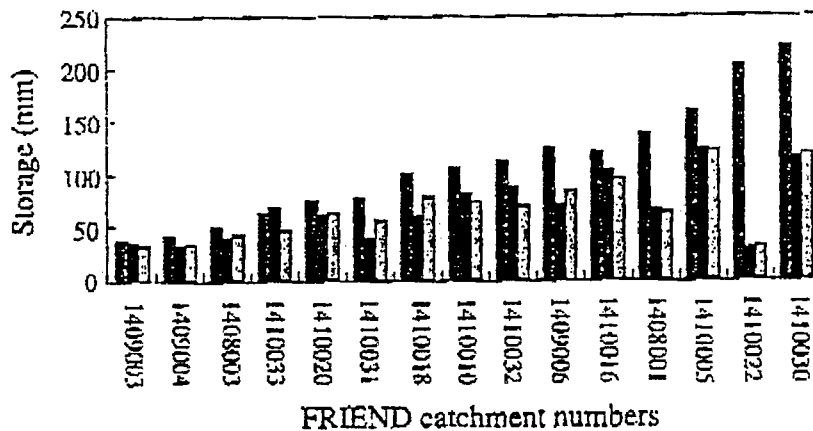

Figure 2 : Storage capacity and observed and predicted *s_{pm}*, versus FRIEND catchment number in the upper Loire basin.

Figure 2 : Capacités de stockage (indice *s_{pm}*) observées et prédéterminées, pour divers bassins de la Loire (n° FRIEND)

Verification of the regional model

To gain more confidence in the validity of the model two additional verification tests were carried out. The physical background of the regional model was investigated with two tests using a conceptual daily discharge model. In the first test, regionally estimated s_c was compared to the storage capacity simulated with the probability discharge model (PDM) of Moore (1985, 1996). In the second test, s_{pm} was compared to storage behaviour as simulated with the PDM. These two tests were carried out on three of the 15 catchments in the Upper Loire basin. The three catchments have low, middle and high estimated storage capacity and high, middle and low catchment sensitivity respectively, as calculated with the regional model. The general applicability of the regional model was tested by applying it to catchments in the Neckar basin (Germany).

The PDM is a daily conceptual discharge model with catchment soil moisture defined by a probability distributed function. This function represents the variation of storage capacity over the catchment. The PDM-parameter s_{max} defines the storage capacity of the catchment and was expected to be equivalent to the regionally determined s_c . Direct flow is generated from saturated stores. Drainage from the soil store provides baseflow. Direct flow and baseflow are routed to the catchment outlet using unit hydrographs. With a variant of this model observed variations in soil moisture and observed storage capacity were accurately simulated by Kalma *et al.* (1995), suggesting that the s_{max} is correctly estimated with this discharge model.

For the first test, discharge was simulated with the discharge model for a calibration and a validation period of both four years for the three catchments. The PDM-parameters were optimized using the Rosenbrock optimization technique. In the three catchments discharge was simulated adequately (Nash-Sutcliffe efficiencies: 0.81, 0.76, 0.74) for the calibration period. The Nash-Sutcliffe efficiencies for the validation period were less good, but this was also observed by Arnell (1996), who used the same model to simulate discharge of catchments in the UK. Flow duration curves were, however, accurately simulated for both periods. Regionally determined s_c closely approximated the PDM-parameter s_{max} for the three selected catchments. Moreover, a sensitivity analysis on the PDM-parameters showed that s_{max} was a very sensitive parameter for model performance. Hence, the same

storage capacities for three catchments were determined with two independent methods. This gives confidence that the regionally determined s_c are estimated well. This analysis is described in Van der Wateren-de Hoog (1997b).

For the second test, discharge was simulated for the three catchments during dry and wet periods using optimized PDM-parameters and regionally determined s_c . The test was carried out in a somewhat roundabout way as not enough climate data were available. A weather generator was used to generate daily precipitation and temperature during the dry and wet periods. The weather generator was adapted to reflect the observed monthly precipitation correctly (van der Wateren-de Hoog, 1996). Simulated and observed duration curves of discharge, soil moisture storage and groundwater storage were compared for the three catchments. These showed that the impact of climate variability was mainly caused by different groundwater behaviour. This confirms the importance of present storage in catchment sensitivity analyses. This analysis is described in detail in Van der Wateren-de Hoog (1997c).

To test its general applicability, the regional model was applied to 24 catchments in the Neckar region. The model parameters defined for the regional model were comparable to those in the Upper Loire region and they were again stable as tested with the jackknifing tool. Storage capacities calculated with the regional model are slightly higher for the Neckar catchments than for the Loire catchments.

Potential use of the regional model

The regional model can be used to assess the spatial distribution of catchment sensitivity and or catchment storage capacity. As an example, figure 3 presents catchment sensitivity under present climate conditions for all available catchments in the Neckar basin. To derive this figure, the regional model as defined for catchments in the Neckar basin for which the assumptions were valid, was applied to all available catchments in the Neckar basin. Figure 3 should be interpreted with care as catchment sensitivity is partly determined for catchments which do not follow the assumptions of the regional model. Further research is necessary to test whether this approach is acceptable. Nevertheless, it shows that a regional pattern emerges, which can be readily interpreted. The lower catchment sensitivities are found in the western part of the Neckar basin. This coincides with rather permeable geology (sandstone and limestone) and catchments with gentle slopes. Higher catchment sensitivities are found on the eastern side of the Neckar basin. These catchments are situated in the Southern German Cuesta which mainly consists of marls. On top of the cuesta the geology consists of limestones. Likewise, it is also possible to graphically present regionally determined storage capacity.

Conclusions

A regional model that quantifies catchment sensitivity to climate variability is developed and verified. The statistical soundness, physical backgrounds and general applicability of the regional model are verified, proving that the regional model can be used to identify present and future catchment sensitivity to climate variability and can also be used to estimate catchment storage capacity. Apart from catchment storage capacity, flood and drought prone catchments can be identified with the regional model. Application of this model on the European scale could yield important information considering regional storage capacity, water resources and potential flood and drought catchments. Assessment of storage capacity is important to improve the description of land surface hydrology in global circulation models that are used to assess the impact of climate change (Loaiciga *et al*, 1996). At present, the application of the regional model is limited to catchments with fairly homogeneous geology and not too steep slopes. Considering its potential use, future research should concentrate on reducing these limitations.

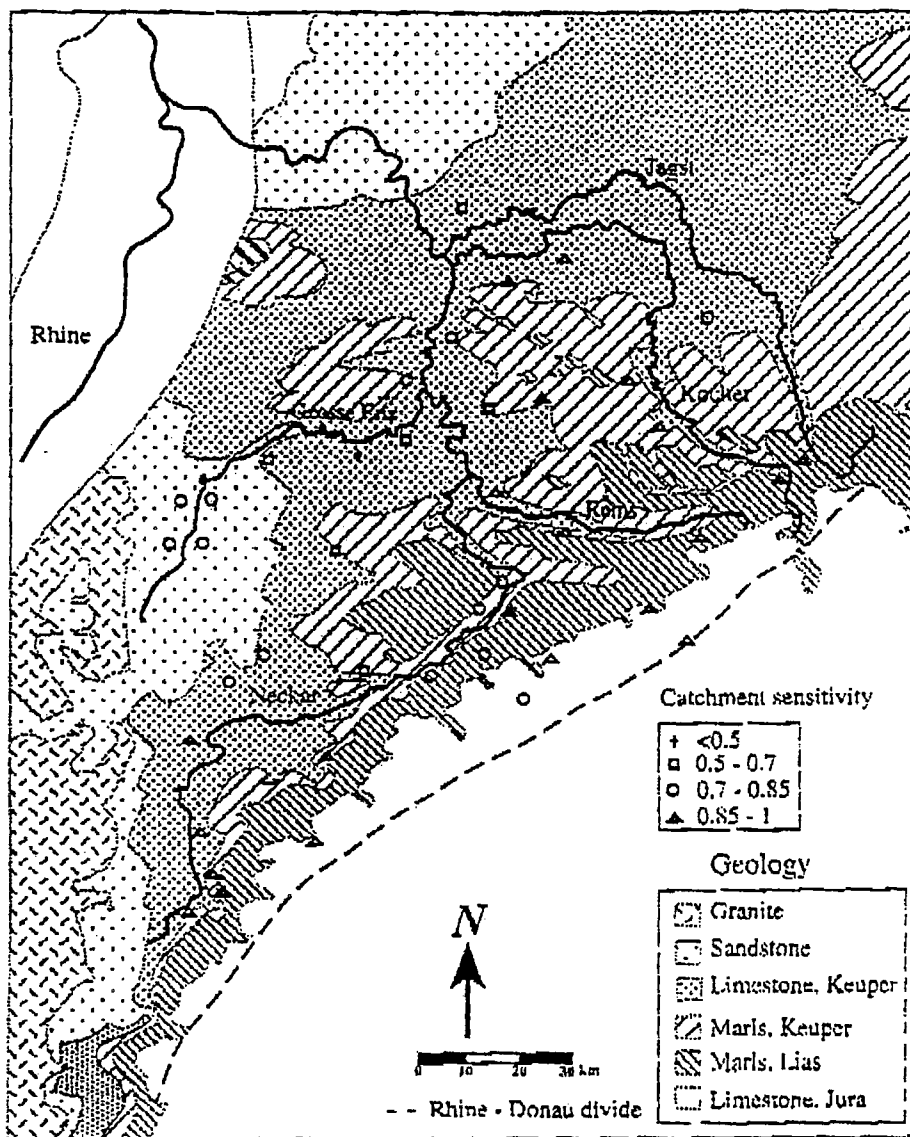

Figure 3 : Spatial distribution of catchment sensitivity in the Neckar basin
Figure 3 : Variation spatiale de la sensibilité dans le bassin du Neckar

Short conclusion

Brève conclusion

N. Arnell

Research presented in this chapter has demonstrated the range of work within FRIEND under the general theme of macro-scale regional hydrology. Rather than review individual conclusions, it is here finished with two general points.

Studies in Europe and Africa have shown spatially-coherent patterns of hydrological anomalies, which have been related - qualitatively - to precipitation and climatic variability. But what are the quantitative relationships, and how do the hydrological anomalies relate to global and regional scale climatic anomalies? Can the temporal and spatial patterns be explained in terms of variations in ENSO, or in the North Atlantic Oscillation? If so, can they be predicted? How do anomalies relate at the global scale *between* continents (and FRIEND projects). How do catchment properties affect response to climatic anomaly?

Regional hydrology - macro-scale hydrology - is a major growth area. It addresses broad-scale issues, and helps in the understanding of global concerns. Regional-scale hydrological analysis and research have a significant role to play in the understanding of global and continental water and energy budgets and fluxes, and can make a major contribution to global research programmes such as GEWEX.

ooooo

Les recherches présentées dans ce chapitre illustrent bien le type de travaux menés dans FRIEND, sous le thème général de l'hydrologie à macro-échelle régionale.

Les travaux réalisés en Europe et en Afrique montrent bien des structures spatiales cohérentes pour les anomalies hydrologiques temporelles qui ont été qualitativement imputées aux variabilités climatiques et pluviométriques. Mais quelles sont les relations quantitatives, et comment estimer ces anomalies hydrologiques par rapport aux anomalies globales ou régionales du climat? Peut-on expliquer ces structures temporelles et spatiales par rapport aux variations de l'oscillation El Nino ou à celles de l'Atlantique Nord? Si tel est le cas, cela peut-il être prévu? Comment ces anomalies sont-elles reliées entre-elles à l'échelle globale inter-continentale? Comment les caractéristiques des bassins influent-elles sur les réponses aux anomalies climatiques?

L'hydrologie régionale, et plus précisément l'hydrologie à macro-échelle, est un domaine en forte croissance. Elle concerne des enjeux à grande échelle, et participe à la compréhension des processus globaux. Les analyses hydrologiques à ces grandes échelles régionales jouent un rôle important dans la compréhension des bilans et des flux d'eau et d'énergie aux échelles globales et continentales et, à ce titre, sont une contribution majeure à des grands programmes de recherche comme par exemple GEWEX.

References of chapter 2

Références bibliographiques du chapitre 2

- Adler M.J., Galéa G. (1996) : Bassin hydrographique du Crisu-Alb (Roumanie), modélisation synthétique des régimes de crue et premiers essais de modélisation synthétique des régimes d'étiage UNESCO PHI IV, Projet FRIEND (H-5-5), Groupe AMHY ; INMH-Bucarest. ; Cemagref, Division Hydrologie-Hydraulique.
- Arnell N., Oancea V., Oberlin G. (1993) : European River Flow Regimes. A Contribution to "Europe's Environment 1993". Report to the European Environment Agency Task Force. CEMAGREF-Lyon and Institute of Hydrology-Wallingford., May 1993.
- Arnell N.W. (1994) : Variations over time in European hydrological behaviour: a spatial perspective. *FRIEND: Flow Regimes from International Experimental and Network Data*. IAHS Publ. 221, 179-184.
- Arnell N.W. (1992) : Factors controlling the effects of climate change on river flow regimes in a humid temperate environment. *Journal of Hydrology*, 132, 321-342.
- Balocki J.B., Burges S.J. (1994) : Relationships between n-day flood volumes for infrequent large floods. *Journal of Water Resources Planning and Management*, 120(6), p794-818.
- Bamba F. (1996) : Bilans hydrologiques 1951-1989 pour des bassins-versants du Haut Niger et analyse de l'évolution des tarissements. Mémoire de fin de 1^{ère} année de Contrat Formation Insertion (CFI), ORSTOM/CNRST, Bamako, 28 p.
- Bamba F., Diabate M., Mahé G., Diarra M. (1995) : Bilans hydrologiques pour des affluents majeurs du fleuve Niger : le Bani, le Sankarani, le Tinkisso et le Milo. Atelier Scientifique FRIEND-AOC UNESCO/PHI, Cotonou, 14-15 déc. 1995, 17p.
- Bamba F., Diabaté M., Mahé G., Diarra M. (1996a) : Rainfall and runoff decrease of five river basins of the tropical upstream part of the Niger river over the period 1951-1989. In : Roald L.A. (Ed.) : Global hydrological change, EGS XXIth Gen. Ass., La Haye Pays Bas, 6-10 mai, 16 p.
- Bamba F., Mahé G., Bricquet J.P. (1996b) : Changements climatiques et variabilité des ressources en eau des bassins du Haut Niger et de la cuvette lacustre. Journées Hydrologiques de l'ORSTOM : « Réseaux hydrométriques, réseaux télématiques, réseaux scientifiques : nouveaux visages de l'Hydrologie Régionale en Afrique », ORSTOM Montpellier, 10-11 octobre 1996.
- Bricquet J.P., Bamba F., Mahé G., Touré M., Olivry J.C. (1995a) : Variabilité des ressources en eau de l'Afrique atlantique. Atelier Scientifique FRIEND-AOC UNESCO/PHI, Cotonou, 14-15 déc. 11p.
- Bricquet J.P., Mahé G., Bamba F., Olivry J.C. (1995b) : Changements climatiques récents et modification du régime hydrologique du fleuve Niger à Koulikoro (Mali). Conférence à la Mémoire de Jean Rodier : L'Hydrologie Tropicale. Géoscience et outil pour le développement. ORSTOM, GIP HydroSystèmes, CNFSH. Mai 1995, UNESCO, Paris.
- Bultot F., Coppens A., Dupries G.L., Gellens D., Meulenberghs F. (1988) : Repercussions of a CO2 doubling on the water cycle and on the water balance a case study for Belgium. *Journal of Hydrology*, 99, 319-347.
- Cemagref-Lyon (1989) : Analyse des crues des petits bassins versants du Sud-Est de la France. Estimation sommaire des débits décennaux et biennaux par des méthodes de type CRUPEDIX et SOCOSE régionalisées. Document de synthèse, IX^{ème} contrat de Plan Etat-Région. Collaboration des laboratoires suivants : LAMA (CNRS, URA 344), SRAE Rhône-Alpes et Provence Côte d'Azur. Producteurs de données : SRAE, SN, EDF, CEMAGREF.
- Cemagref-Lyon (1992) : INONDABILITE, modélisation des connaissances hydrologiques et hydrauliques en vue d'une confrontation "Risques/Besoins de Protection" directe, Synthèse cartographique. X^{ème} PLAN : contrat Etat-Région Rhône-Alpes, risques naturels en montagne, crues en rivières et inondations en vallées. Rapport final 1989-1992, Octobre 1992.
- Colin E., Michel C., Oberlin G. (1977) : Applications du calcul de la distribution d'une fonction de deux variables à l'estimation des crues. Division Hydrologie-Hydraulique Fluviale, CTGREF.
- CTGREF, SRAE, DIAME, SH 1980-1982 : Synthèse nationale sur les crues des petits bassins versants. Fascicule 2 : la méthode SOCOSE, Information Technique n°38-2 (Juin 1980) ; Fascicule 3 : la méthode CRUPEDIX.
- Diabaté M. (1995) : Etude des variations hydroclimatiques sur le bassin-versant du Bani de 1950 à 1990. Mémoire d'Ingénieur de l'ENI, Option Génie Civil, Aménagements Hydrauliques, ENI/ORSTOM, Bamako, 64 p.
- Diaconu C., Serban P. (1994) : Synthesis and Regionalization in Hydrology (in Romanian). Editura Tehnica, Bucharest.
- Dracup J.A., Kahya E. (1994) : The relationships between US streamflows and La Nina events. *Water Resources Research* 30, 2133-2141.

- Fraedrich K., Müller H. (1994) : Climate anomalies in Europe associated with ENSO extremes. *Int. J. Climatol.* 12, 25-32.
- Galéa G., Prudhomme C. (1993) : Characterization of large scale variations in river flow behaviour with reference to hydrological macro-regionalization. Technische Universität Braunschweig (Allemagne), FRIEND Conference, 11-15 October 1993, AISH n° 221.
- Galéa G., Prudhomme C. (1994a) : The mono frequency synthetic hydrogramm (MFSH) concept, definition, interest and construction from regional QdF models built with threshold discharges, for little mountaineous basins with rapid runoff. International Conference 12-16 September 1994 Stara Lesna (Slovakia).
- Galéa G., Prudhomme C. (1994b) : Modèles débit-durée-fréquence et conceptualisation d'un hydrogramme de crue synthétique : validation sur le BVRE de DRAIX - Hydrologie Continentale, 1994, vol 9 n°2.
- Galéa G., Prudhomme C. (1996) : Notions de base et concepts utiles pour la compréhension de la modélisation synthétique des régimes de crue des bassins versants au sens des modèles QdF. Cemagref-Lyon, Division Hydrologie-Hydraulique, LHM, Université Montpellier II. Article accepté à Sciences de l'Eau.
- Galéa G., Ramez P. (1995) : Maîtrise du ruissellement et de l'érosion en vignoble de coteau. Guide à l'usage des aménageurs. Cemagref-Lyon Div. Hydrologie-Hydraulique.
- Galéa G., Schuitema N. (1989) : Aménagement hydraulique rationnel, courbes débit-durée-Fréquence, validation d'une formulation sur la région Bourgogne et extrapolations. Conseil Régional et SRAE de Bourgogne, Cemagref-Lyon, Division Hydrologie-Hydraulique, Landbouw Universiteit Wageningen.
- Gilard O., Oberlin G., Chastan B., Givone P. (1993) : INONDABILITE, une méthode pour gérer rationnellement l'occupation des sols en lit majeur. Réunion du 17.11.93 de la V^{ème} section du CGGREF.
- Gottschalk L., Jensen J.L., Lundquist D., Solantie R., Tollan A. (1979) : Hydrological regions in the Nordic Countries. *Nordic Hydrology*, 10, 273-286.
- Grand F., Galéa G. (1996) : Dimensionnement optimal du volume d'une retenue d'écroulement, comparaison des approches QdF et du laminage hydrologique. Cemagref-Lyon Div. Hydrologie-Hydraulique, ENGEES (mémoire de 3^{ème} année).
- Grissolet H., Guilmet B., Arlery R. (1962) : Climatologie - Méthodes et pratiques - Gauthiers-Villars & Cie Editeur - Paris.
- Gustard A. (1993) : Flow Regimes from International Experimental and Network Data (FRIEND), Institute of Hydrology, p. 210.
- Hubert P., Carbonnel J.P. (1987) : Approche statistique de l'aridification de l'Afrique de l'Ouest. *Journal of Hydrology*, 95: 165-183.
- Hurrell J.W. (1995) : Decadal trends in the North Atlantic Oscillation: regional temperature and precipitation. *Science* 269, 676-679.
- Jin L., Galéa G. (1990) : Modèles descriptifs synthétiques des connaissances régionales en crues, représentativité spatiale et domaine de validité. DEA ULPS/ENITRTS Strasbourg, Cemagref-Lyon Div. Hydrologie-Hydraulique.
- Kalma J.D., Bates B.C., Woods R.A. (1995) : Predicting catchment-scale soil moisture status with limited field measurements. *Hydrological processes*, 9, 445-467.
- Krasovskaia I., Gottschalk L. (1992) : Stability of river flow regimes. *Nordic Hydrology*, 23, 137-154.
- Krasovskaia, I., Gottschalk, L., Arnell, N.W. & Wateren-de Hoog, B. (1993): Variations in Regime Class over Time. In: Flow Regimes from International Experimental and Network Data (FRIEND). Hydrological studies, Vol.1, ed. A.Gustard, Institute of Hydrology, Wallingford, UK: 131-138.
- Krasovskaia, I., Arnell, N.W. & Gottschalk, L. (1994): Flow Regimes in Northern and Western Europe: Development and Application of Procedures for Classifying Flow Regimes. IAHS Publ. 221: 185-193.
- Krasovskaia I. (1995) : Quantification of the stability of the river flow regimes. *Hydrological Sciences Journal*, Vol. 40, No. 5, : 587-598.
- Krasovskaia, I. (1996): Grouping River Flow into Regime Types by Means of Optimization of an Entropy-Based Objective Function. Submitted for publication.
- Krasovskaia, I. (1996): Sensitivity of the Stability of River Flow Regimes to Small Fluctuations in Temperature. *Hydrol. Sci. J.* 41: 251-264.
- Krasovskaia, I. & Saelthun, N.R. (1996): Sensitivity of the Stability of Scandinavian River Flow Regimes to a Predicted Temperature Rise. Accepted for publication in *Hydrol. Sci. J.*
- Kullback, S, & Leibler, R.A. (1951): On information and sufficiency. *Ann. Math. Stat.*, 22: 79-86
- Lang M. (1995) : Les chroniques en hydrologie : modélisation comparée par un système de gestion de bases de données relationnel et orienté-objet. Traitements de base et intervalles de confiance des quantiles de crues. Techniques d'échantillonnage par la méthode du renouvellement. Thèse de doctorat ; Ministère de l'Équipement - Cemagref, groupement de Lyon Division Hydrologie-Hydraulique - Juin 1995.

- Laraque A., Mahé G., Orange D., Marieu B., Olivry J.C. (1997) : Variations spatio-temporelles de la baisse des régimes pluviométriques et hydrologiques en Afrique Centrale pour *Journal of Hydrology* (en cours).
- Laraque A., Olivry J.C., Mietton M., Pandi A (1996) : Influence des couvertures lithologiques et végétales sur les régimes et la qualité des eaux des affluents congolais du fleuve Congo-Zaïre, *Revue des Sciences de l'Eau*, Univ. du Québec, St Foy, Canada, 14 p (accepté).
- Laraque A., Olivry J.C. (1995) : Evolution de l'hydrologie du Congo-Zaïre et de ses affluents rive droite et dynamique de ses transports solides et dissous - rev. AIHS, Wallingford, 23 p (sous presse).
- L'Hote Y., Mahé G. (1996) : Afrique de l'Ouest et Centrale, Précipitations moyennes annuelles (période 1951-1989). Echelle 1/6 000 000^{ème}. Collection des cartes ORSTOM, ORSTOM Ed.
- Loaiciga H.A., Valdes J.B., Vogel R., Garvey J., Schwarz H. (1996) : Global warming and the hydrologic cycle. *Journal of Hydrology*, 174, 83-127.
- Lubès H., Masson J.M., Servat E., Paturel J.E., Kouamé B., Boyer J.F. (1994) : Caractérisation de fluctuations dans une série chronologique par application de tests statistiques. Etude bibliographique. Programme ICCARE. Rapport n°3. ICCARE. ORSTOM, Montpellier, Côte d'Ivoire. Juin 1994.
- Mahé G., Delclaux F., Crespy A. (1994) : Elaboration d'une chaîne de traitement pluviométrique et application au calcul automatique de lames précipitées (bassin-versant de l'Ogoué au Gabon). *Hydrologie Continentale*, vol 9, n°2, 169-180.
- Mahé G., Olivry J.C. (1995) : Variations des précipitations et des écoulements en Afrique de l'Ouest et Centrale de 1951 à 1989. *Sécheresse* 1, vol 6: 109-117.
- Mahé G., Olivry J.C. (1995) : Variations des précipitations et des écoulement en Afrique de l'Ouest et Centrale de 1951 à 1989, *Sécheresse*, n°1, vol 6, 109-117.
- Margoum M. (1992) : Estimation des crues rares et extrêmes : le modèle AGREGEE, conception et premières validations. Thèse de doctorat ; GIS Hydrologie AMHY-FRANCE, Cemagref Lyon, Division Hydrologie-Hydraulique, Ecole des Mines de Paris -Soutenue le 30 Juin 1992.
- Michel C. (1982) : Extrapolation par la méthode du GRADEX. Note interne KG 03.05.82, Cemagref-Antony, Div. Hydrologie.
- Moore R.J. (1985) : The probability-distributed principle and runoff production at point and basin scales. *Hydrological Sciences Journal*, 30, 273-297.
- Moore R.J. (1996) : A guide to the PDM. Institute of Hydrology, Wallingford, pp 25.
- Nicholson S.E., Kim J., Hoopingarner J. (1988) : Atlas of African rainfall and its interannual variability. Department of Meteorology, Florida State University, Tallahassee, Florida, USA.
- Oancea V., Oberlin G., Mic R. (1995) : Comparison of synthetic hydrographs computing methods, IUGG, XXI General Assembly, Symposium HW3, 2-14 july, 1995, Boulder (*Colorado-Etats-Unis*), 43 p
- Oancea V., Stanescu A. V., Mic R. (1994) : Application of QdF models in regional analysis of rare floods. International Conference 12-16 September 1994 Stara Lesna (Slovakia).
- Oberlin G. (1992) : Normalisation des variables dans les modèles hydrologiques descriptifs. Informations Techniques du Cemagref, mars 1992, n°85, note 4.
- Oberlin G., Ben Mansour H., Ortiz R. (1989) : Generalization and standardization for 3 types of flow-duration-frequency curves in flood regime description and transfer. FRIEND, Bolkesjö, AISH n°187.
- Orange D., Feizouré C., Laraque A., Wesselink A. (1996) : Hydroclimatological changes on the Central African Continent : evidence from the Oubangui river. *Physics and Chemistry of the Earth*, Edn EGS, 7p. (sous presse).
- Paturel J.E., Servat E., Kouamé B., Lubès H., Masson J.M. (1997) : Manifestation d'une variabilité hydrologique en Afrique de l'Ouest et Centrale. Accepté à 5th Scientific Assembly of the International Association of Hydrological Sciences, Symposium 1 - Sustainability of water resources under increasing uncertainty. 23 April - 3 May 1997, Rabat, Maroc.
- Paturel J.E., Servat E., Kouamé B., Lubès H., Ouedraogo M., Masson J.M. (1996) ; Climatic variability in humid Africa along the Gulf of Guinea. Part two: An integrated regional approach. Accepté pour publication à *J. Hydrol.*
- Prudhomme C. (1995) ; Analyse et régionalisation des régimes hydrologiques méditerranéens. Thèse de Doctorat en Hydrologie soutenue le 8 décembre 1995. Cemagref-Lyon, Division Hydrologie-Hydraulique, LHM Montpellier II.
- Prudhomme C., Lang M. (1994) ; Adaptation du modèle régional QdF au modèle d'extrapolation AGREGEE. International Conference 12-16 September 1994 Stara Lesna (Slovakia).
- Schumm S.A. (1956) : Evolution of drainage systems and slopes in badlands at Perth Amboy, New Jersey. *Bulletin of the American Geological Society*, 67, 597-646.

- Servat E., Paturel J.E., Lubès H., Kouamé B., Ouedraogo M., Masson J.M. (1996) : Climatic variability in humid Africa along the Gulf of Guinea. Part one: Detailed analysis of the phenomenon in Côte d'Ivoire. *Accepté pour publication à J. Hydrol.*
- Shannon C. E., Weaver W. (1941) : *The Mathematical Theory of Communication*. University of Illinois Press, Urbana, USA.
- Shannon,C.E. (1948): A mathematical theory of communication. *Bell System Tech. J.*, 27: 379-423, 623-656
- Soumaguel A. (1996a) : Annuaire des précipitations annuelles sur le bassin du Niger supérieur et le Delta Central de 1924 à 1995. Rapport d'activité, Friend AOC, ORSTOM Bamako, 45 p.
- Soumaguel A. (1996b) : Elaboration des fichiers opérationnels pour le calcul régionalisé des pluies par la méthode du vecteur régional sur le bassin versant du Niger. Rapport d'activité, programme Friend AOC, ORSTOM Bamako.
- Soumaguel A., Mahé G., Diarra M., Camara A. (1996) : Annuaire des précipitations mensuelles et annuelles de l'origine des stations à 1995 au Mali. Tome 1 (A à K) 77p., tome 2 (L à Z) 58 p., tome 3 (postes récents ou projets) 22 p.
- Sourisseau J., Galéa G. (1996) : Représentativité des modèles QdF, application à la régionalisation des régimes de crue du bassin versant de la Loire. Cemagref, groupement de Lyon - Division Hydrologie Hydraulique ; EPFL - IATE ; Ministère de L'Environnement - Direction de l'Eau.
- Stanescu V. Al. (1967) : Danube between Bazias and Ceatal Izmail (in Romanian). ISCH Press, Bucharest.
- Tallaksen L.M. (1989) : Analysis of time variability in recessions. in: *Friends in Hydrology*, IAHS 187, 85-96.
- Theil,H. (1967): *Economics and Information Theory*. North-Holland Publ.Company, Amsterdam
- Ventsel,E.S. (1964): *Teoriya verojatnostej (Probability Theory)* In Russian. Nauka, Moscow.
- Van der Wateren-de Hoog B. (1995) : The effects of climate variability on discharge as dependent on catchment characteristics in the Upper Loire Basin, France. *Hydrological Science Journal*, 40, 633-646.
- Van der Wateren-de Hoog B. (1996) : Adaptation of a daily weather generator to represent long term precipitation persistence. ICG-report 1996/3, Utrecht University, The Netherlands, 16 pp.
- Van der Wateren-de Hoog B. (1997a) : A regional hydrological model to assess the sensitivity of medium size catchments to climate variability. *Hydrological Processes (in press)*
- Van der Wateren-de Hoog B. (1997b) : Catchment sensitivity to climate variability as dependent on: I. Storage capacity, *Hydrological Processes, (submitted)*.
- Van der Wateren-de Hoog B. (1997c) : Catchment sensitivity to climate variability as dependent on: II. Catchment storage capacity, *Hydrological Processes, (submitted)*.
- Waylen P.R., Caviedes C. (1990) : Annual and seasonal fluctuations of precipitation and streamflow in the Aconcagua river basin, Chile. *J. Hydrol.* 120, 79-102.
- Wesselink A., Feizouré C., Orange D., Randriaminasoria. (1995) : Les régimes hydroclimatiques et hydrologiques d'un bassin versant de type tropical humide : l'Oubangui - rev. AIHS, Wallingford, 10 p (sous presse).
- Wotling G. (1994) : Analyse de la variabilité spatio-temporelle des précipitations annuelles liées à la mousson africaine de 1951 à 1989. Application de la méthode du vecteur régional (MVR). Mémoire de DEA National d'Hydrologie, option Gestion et Valorisation de l'Eau. ORSTOM - UMII LHM, Montpellier, 121 p.
- Wotling G., Mahé G., L'Hote Y., Le Barbé L. (1995) : Analyse par les vecteurs régionaux de la variabilité spatio-temporelle des précipitations annuelles liées à la mousson africaine. *Veille Climatique Satellitaire*, 52, 58-73.

Chapter 3

Low flows and droughts

Short introduction

A. Bullock

The concepts and methods of analysing low flows and droughts share many common issues with floods, based fundamentally on frequency analysis of extreme events. Yet, within the evolution of analytical hydrology as a science the analysis of low flows and droughts has historically been the poor relation. In the most recent decades, however, concern about low flows and drought has substantially increased. A major part of this concern has been stimulated by recent severe and widespread drought in many regions of the world, which have alerted the public, operational supply agencies, governments and hydrologists to the significant impacts of water shortages. Naturally-occurring droughts are not, of course, a recent phenomenon but they assume greater significance in impact as water availability falls short of increasing demand. Many countries around the world are now projecting water scarcity early in the next Century, as demand exceeds supply on a periodic basis. In essence, the impact of a 25-year return period drought event on the human population and the environment now has potentially greater implications for water shortage than an equivalent event occurring earlier this Century, depending on the water industries supply and demand management responses.

In an industry in which supply-side solutions have predominated, it is perhaps not surprising that extreme value analyses have placed floods ahead of droughts. During reservoir design and construction, prevalent in the past but now in decline, it is essential that rigorous spillway design prevents dam failure and subsequent loss of life. Reliable yields to be supplied by reservoirs were estimated during the design stage based on demand projections, for perhaps 25 to 50 years ahead. In many regions of the world, the period since the mid-1970 has witnessed a time when reliable water supply and demand have coincided, and in many cases have become critical. This current status is compounded by scenario-based projections of climate change, within which the balance of opinion is towards decreased water availability.

But it is not only water supply from impoundments which is at risk. There has been an expansion in direct river abstraction and a general shift in emphasis towards small-scale water development schemes, with many of these abstractions within small catchments. Without the storage capacity of a regulating reservoir to provide carry-over storage from periods of surplus into periods of deficit, such abstractions are particularly prone to low flows and drought. In issuing rights to abstract water, operational agencies have an increased need to be able to estimate reliable levels of river flow at large numbers of (ungauged) locations. Furthermore, there has also been a revolution in the perception of the river ecology as a user of water within the past decade or so. Rivers are now increasingly managed to protect river ecology from excessive abstraction and regulation, requiring knowledge of the characteristic natural regimes of river systems, and the demands of ecological communities which need to be preserved. Moreover, the water industry is manoeuvring itself, in a somewhat fitful manner, to combining supply-side solutions with demand management. Associated with this is a requirement to alter the perspective of water as a naturally abundant resource towards one of occasional (or indeed frequent) shortage, thereby raising the profile of drought in the population at large.

Academic hydrologists in many countries around the world have contributed their expertise to the

design of individual supply schemes and environmental protection, or towards national water resource assessments. Additionally, planning for shortage is a high priority within many national water agencies. It is therefore not surprising that academic scientists within the European FRIEND projects and the water agencies defining the agenda of the African FRIEND groups have each determined that low flows and droughts should be an integral component of the first FRIEND programme to be implemented in any region. The international commonality of low flow and drought issues establishes this topic as one for which significant advances can be made by methodological and technological development. The topic of low flows and droughts has been pursued in accordance with two underpinning principles of FRIEND - that international data sets should be analysed rather than studies of purely national interest, and to evaluate the performance of models under different circumstances.

These two dimensions are addressed within the set of five papers presented in this Chapter. Three of the five presented papers summarise work undertaken within three regional FRIEND groups

- "Low flow regimes in Western Europe", which describes the application of two approaches to low flows : a regional statistical approach and a physically-based modelling approach.
- "Regional water resources and drought assessment in Southern African", which describes studies of mean annual runoff, base flow, flow duration curves and low flow frequency analyses.
- "Long-term effects of rain-shortage in West and Central Africa", which examines recent trends in low flows in response to continuous and widespread rainfall deficit.

Two other papers summarise work undertaken in the Alpine-Mediterranean region, during the recent introductory phase of this topic:

- "Drought in South-Eastern Europe", which describes recent hydrometeorological extreme events in that region.
- "Statistical analysis of low flows with zero discharge", which recalls the application of the theorem of total probability for time series in semi-arid and snow-affected regions of the world.

oooo

Brève introduction

A. Bullock

Les concepts et méthodes d'analyses des étiages et des sécheresses se partagent de nombreux points communs avec ceux des crues, basés prioritairement sur des analyses de fréquences d'événements rares. Cependant, dans le cadre du développement scientifique de l'hydrologie analytique, les étiages et les sécheresses ont été le parent pauvre. Cependant, depuis les plus récentes décennies, la prise de conscience vis à vis des étiages et des sécheresses s'est considérablement développée. Ceci est en grande partie le résultat de la stimulation induite par de récentes sécheresses, sévères et étendues dans beaucoup de régions du monde, qui ont alerté le public, les distributeurs d'eau, les gouvernements et les hydrologues, sur les impacts significatifs des pénuries d'eau. Les sécheresses naturelles ne sont évidemment pas des phénomènes récents, mais elles prennent de l'importance via leurs impacts, au fur et à mesure que le niveau des ressources disponibles est rattrapé par une demande croissante. De nombreux pays, partout dans le monde, envisagent des pénuries d'eau possibles dès le début du siècle prochain, avec des demandes qui dépassent périodiquement les ressources. Pour l'essentiel, l'impact sur la population et l'environnement d'une sécheresse de durée moyenne de retour de 25 ans a maintenant des effets plus forts en matière de pénurie d'eau, qu'un événement équivalent au début de ce siècle, compte tenu des réactions au niveau de la distributions d'eau et des exigences de gestion.

Dans une activité industrielle où les choix de fourniture d'eau à partir de réservoirs ont prédominé, il n'est peut-être pas étonnant que l'analyse des valeurs extrêmes ait placé les crues avant les sécheresses. En effet, pendant les phases de conception et de construction des barrages, phases très actives dans le passé mais à présent sur le déclin, il est essentiel qu'une conception rigoureuse des déversoirs de crues prévienne les ruptures et les pertes de vies humaines induites. Par ailleurs, les estimations fiables des ressources que peuvent assurer des réservoirs sont réalisées pendant la phase de conception, avec une projection de demandes à échéances de 25 ou 50 ans. Or, dans maintes régions du monde, et depuis le

milieu des années 70 environ, on a observé un tendance à la coïncidence entre ressources assurées et demandes, avec un nombre croissant de cas devenant critiques. Cette situation courante de base est à présent combinée avec des scénarios de changements climatiques, parmi lesquels l'opinion privilégie ceux qui affichent une décroissance des ressources en eaux disponibles.

Mais ce ne sont pas seulement les ressources issues de réservoirs qui présentent des risques de défaillances. Il y a eu un très fort développement des prélèvements directs en rivières, dans une évolution générale privilégiant les schémas de gestion des eaux sur de petits périmètres, avec donc une majorité de tels prélèvements en petits bassins amont. Sans les capacités de stockages d'un réservoir qui peut assurer un transfert des volumes des saisons excédentaires vers les saisons déficitaires, de tels prélèvements sont particulièrement vulnérables aux étiages et aux sécheresses. Pour déboucher sur des règles en matière de droits de prélèvements, les agences responsables ont besoin croissant d'estimation des débits et niveaux sur un grand nombre de sites en rivières (non observés). En outre, il y a aussi eu une quasi révolution dans la décennie passée, de par la perception écologique du milieu comme étant un des usagers de l'eau. Les rivières sont à présent de plus en plus gérées pour protéger leur milieu de prélèvements ou de régularisations excessifs, ceci exigeant une connaissance des caractéristiques naturelles des régimes du réseau hydrographiques, ainsi qu'une connaissance des besoins des diverses communautés biologiques, afin de les préserver. Enfin, l'industrie elle-même est en train de manoeuvrer, mais de façon quelque peu désordonnée, combinant les solutions de fourniture de type réservoirs avec une gestion de la demande. En conséquence de tout ceci apparaît l'exigence de devoir tempérer la vision de ressources en eau abondantes, pour développer celle de pénuries, au moins occasionnelles sinon fréquentes, et faire ainsi émerger le concept de possibles sécheresses dans l'ensemble de la population.

Les scientifiques hydrologues ont, dans maints pays du monde, souvent apporté leur expertise à la conception de schémas locaux de distribution d'eau et de protection de l'environnement, ou à l'estimation des ressources en eaux, par exemple à l'échelle nationale. En outre, les schémas de prévention et de gestion des pénuries sont devenus de première priorité dans nombre d'agences nationales des eaux. Il n'est donc pas étonnant que, d'une part, les scientifiques hydrologues des Groupes FRIEND européens et, d'autre part, les agences de l'eau qui ont préparé les programmes des Groupes FRIEND en Afrique, aient tous deux été amenés à faire des étiages et des sécheresses une composante intégrale des tous premiers programmes FRIEND implantés dans leurs régions. La dimension internationale de nombre de problèmes liés aux étiages et aux sécheresses, conduit à ce que cette thématique soit une de celles qui profite le plus des progrès de type méthodologique et technique. Ces thèmes ont ensuite été poursuivis en accord avec deux des principes de FRIEND : il est préférable d'analyser des données d'envergure internationale que de se limiter à des jeux seulement nationaux, et il faut évaluer les performances des modèles sous différentes conditions d'application.

Ces deux principes ont été servis dans les cinq contributions présentes dans ce chapitre. Trois d'entre elles résument des travaux entrepris dans trois Groupes régionaux de FRIEND.

- "Régimes d'étiages en Europe de l'Ouest", qui décrit la mise en oeuvre de deux approches des étiages : une approche de statistiques régionales, et une approche de modélisation à base physique.
- "Ressources en eaux régionales et estimation des sécheresses en Afrique Australe", qui décrit des études menées sur les débits annuels moyens, les débits de base, les débits classés et les distributions de fréquences des étiages.
- "Effets à long terme des déficits pluviométriques en Afrique de l'Ouest et Centrale", qui analyse les récentes tendances en étiages, en réponse aux déficits persistants et de vaste extension spatiale.

Les deux autres contributions résument des travaux entrepris dans le Groupe AMHY, lors de la phase préliminaire du lancement récent de ce thème:

- "Sécheresses en Europe du Sud-Est", qui décrit de récents événements hydrométéorologiques extrêmes dans cette région.
- "Analyse statistique des étiages avec débits nuls", qui rappelle les conditions d'application du théorème des probabilités composées, pour de telles séries temporelles d'étiages en zones arides ou en zones à saison très froide.

Low Flows and Droughts in Northern Europe

Etiages et sècheresses en Europe du Nord

A. Gustard (ed.), O. Novicky, S. Demuth, L. Tallaksen, H. van Lanen, B. Clausen, L. Kasparek, P. Miklanek, O. Majercakova, M. Fendekova, E. Kupszyk, L. Radsuk, W. Czamara

1 Introduction

The flow characteristics of a river are fundamental to the assessment of water resources for a wide range of direct and indirect uses. These include irrigation, hydropower, the provision of public water supply, the dilution of domestic and industrial effluents and the maintenance of instream habitat and the amenity value of rivers. In order to design a sustainable resource system it is essential to assess the frequency of the low flow behaviour of rivers. This chapter presents a definition of drought from the perspective of analysing daily streamflow, it describes the development of software used to analyse droughts and the sensitivity of drought frequency to different criteria for defining droughts. Two methods have been implemented for evaluating European droughts: a regional statistical approach and a physically based modelling approach. The former analysed the onset, duration and severity of droughts in south west Germany, the seasonality of droughts over Europe and the growth and decay of European droughts based on the probability of a given discharge being exceeded.

These regional studies were complemented by a physically based modelling approach. A number of catchments with contrasting hydrogeology and physical characteristics were selected from different parts of Europe and modelled using several deterministic models. These were calibrated using a number of variables including precipitation, evaporation, streamflow, and groundwater levels and the sensitivity of the catchments to rainfall deficiencies was assessed. Selected simulated flow series were then analysed using the same techniques as in the regional analysis and the results from the two approaches compared. The final section of the chapter describes a technique for estimating the spatial variability of the mean annual ten day minima by relating flow statistics to catchment characteristics. This technique enables low flows to be estimated at sites which do not have measured flow data.

2 Definition of drought events

Droughts are regional in nature and critical drought conditions occur when there is extreme shortage of water for long durations over large areas. Drought studies, such as those completed by Mawdsley, Petts and Walker (1993) or Rossi *et al.* (1992), identified a number of different variables and indicators that can be used for drought definition. In this joint study, carried out in the framework of FRIEND, the focus is on hydrological droughts in terms of streamflow deficits.

Low flow studies traditionally characterize droughts in terms of the minimum annual n-day average discharge. In the United States and in the United Kingdom, n equal to seven days is the most common definition (TCLFE, 1980; Gustard *et al.*, 1992). The method, however, considers only one measure of the drought, the drought magnitude, which may be insufficient in some applications. A method that simultaneously characterizes streamflow droughts in terms of duration and deficit volume is the threshold level method presented by Yevjevich (1967), which defines droughts as periods during which the flow is below a certain threshold level. Using this approach, Clausen & Pearson (1996) concluded from a comparison of drought frequencies that the 1993/94 drought in New Zealand was extreme because of its duration rather than its magnitude.

The definition by Yevjevich (1967) was originally based on the statistical theory of runs for analyzing a sequential time series with a time resolution of one month or longer. Statistical properties of the

a sequential time series with a time resolution of one month or longer. Statistical properties of the distributions of water deficits, run-length (drought duration) and run-sum (deficit volume) were recommended as parameters for at-site drought definition. The method provides an objective definition of droughts which forms the basis for characterization of regional or large area droughts, and has also been used in the analysis of streamflow droughts from a daily recorded hydrograph (Zelenhasic & Salvai, 1987; Tallaksen *et al.*, 1997). The threshold level approach is adopted in this study for analyzing droughts using both monthly and daily time series.

The sequence of drought events is obtained from the streamflow hydrograph by considering flow situations where the discharge is below a certain threshold level q_0 (Figure 1). Each drought event is characterized by its duration d_i , deficit volume (severity) s_i , and time of occurrence τ_i . The time of drought occurrence is defined as the mean of the onset and the termination date of the drought. During a prolonged dry period it is often observed for daily time series that the flow exceeds the threshold level for a short period of time and thereby divides a large drought into a number of minor droughts that are mutually dependent. Thus, a consistent definition of drought events should include some kind of pooling in order to define an independent sequence of droughts.

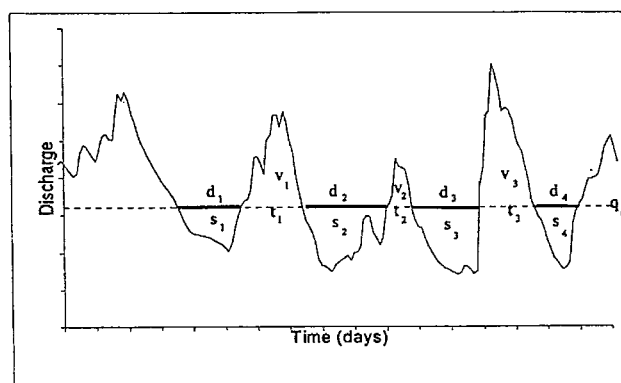

Figure 1 : Definition sketch: q_0 =threshold level, d_i =duration, s_i =deficit volume, t_i =interevent time and v_i =interevent excess volume.

Figure 1 : Schéma des définitions : q_0 =seuil, d_i =durée, s_i =déficit, t_i =intervalle et v_i =volume des phases excédentaires

Three basic methods for pooling dependent droughts were included in this study. Using the interevent time and volume based criterion (IC) two subsequent events are pooled into a single drought event if :

- i) the ratio between the interevent time t_i and the preceding deficit duration d_i is less than a predefined critical ratio r_c :

$$t_i < r_c \cdot d_i$$

or alternatively, the interevent time t_i between the events is less than or equal to a critical duration t_c :

$$t_i \leq t_c$$

- ii) the ratio between the interevent excess volume v_i and the preceding deficit volume s_i is less than a predefined critical value p :

$$v_i < p_c \cdot s_i$$

This drought is pooled with the next drought if i) and ii) are fulfilled using the pooled drought characteristics calculated as:

$$\begin{aligned} d_{pool} &= d_i + d_{i+1} + t_i \\ s_{pool} &= s_i + s_{i+1} - v_i \end{aligned}$$

as the preceding duration and deficit volume. Criteria i) and ii) are respectively denoted the interevent time and interevent volume criterion.

The moving average (MA) procedure, with averaging time step t_a , is applied to the time series prior to selecting the droughts. In this case the time series is smoothed and minor peaks above the threshold level removed, and some droughts are implicitly pooled as part of the averaging process. If two droughts are pooled, there will be a reduction in the drought volume, but not in the duration of the drought. Thus, the drought characteristics of the moving average series are consistent with the definition of the pooled characteristics of the IC method.

The most commonly used procedure for design of reservoirs based on annual streamflow data is the mass curve or its equivalent, the sequent peak algorithm (SPA). By analogy, let q_i denote the daily inflow to a reservoir and q_0 the desired yield, then the storage w_i required at the beginning of the period I reads :

$$w_i = \begin{cases} w_{i-1} + q_0 - q_i, & \text{if positive} \\ 0 & , \text{otherwise} \end{cases}$$

An uninterrupted sequence of positive w_i defines a period with storage depletion and subsequent filling up. The required storage in that period, $\max\{w_i\}$, defines the drought deficit volume and the time interval from the beginning of the depletion period to the time of the maximum depletion defines the drought duration. Based on this method two droughts are pooled if the reservoir has not totally recovered from the first drought when the second drought begins. The method is closely related to the IC method for $p_c=1$. However, as opposed to the IC method, the SPA method also compares the interevent volume with the subsequent deficit volume when calculating the pooled drought characteristics. The subsequent deficit volume must be larger than the interevent volume in order to affect the estimation of $\max\{w_i\}$.

Statistical analysis of selected drought characteristics can be performed either on annual maximum series (AMS) or partial duration series (PDS). In the AMS approach the largest event within a hydrometric year is extracted, whereas PDS generally considers all drought events below a given threshold. A potential problem of the PDS approach is the large number of minor droughts which may distort the extreme value modelling.

3 Software development and models used

The above definitions, criteria and rules were used as a basis for development of a computer program, the EXDEV (Experiments with Deficit Volumes) program. The program, which was developed in the Czech Hydrometeorological Institute within the framework of the FRIEND project, selects drought events from daily flow (or base flow) series and performs statistical analyses including the application

of several probability distributions to the annual or partial series. Program options include calculation and selection of the threshold discharge, linear interpolation techniques for filling in missing data, calculation of moving average series and its subsequent analysis, and graphical interpretation of results.

Three types of physically based models were used in this study to simulate stream flow under different conditions. The first type, represented by the BILAN model developed in the T.G. Masaryk Water Research Institute, Prague, lumps the processes and parameters in a catchment. The entire catchment is represented by one cell. The second type is a semi-distributed model, i.e. *HBVMOR* (Tallaksen, 1993), which combines a rainfall-runoff submodel with a specialized evapotranspiration submodel. The third type is characterized by a distributed nature, e.g. the MODFLOW model. In the latter type of models the flow domain (catchment) is discretized, enabling complex catchment geometry and spatially distributed parameters, such as permeability and recharge, to be accounted for (van Lanen *et al.*, 1993).

The BILAN water balance model uses monthly precipitation, relative humidity and air temperature data as input (Kašpárek & Krejcová, 1994). Areal evapotranspiration, surface runoff, interflow and base flow are simulated taking into account snow storage, soil moisture storage and groundwater storage. Model parameters, such as the parameter controlling the relationship between base flow and groundwater storage, are optimized by comparing simulated and observed runoff.

The HBVMOR model is also a single-cell model, but considers different zones in a catchment to account for snow accumulation and redistribution. The model uses a substantially smaller time step than BILAN, ranging from 1 to 24 hours depending on the process to be simulated. HBVMOR is developed for a detailed analysis of catchment behaviour and associated stream flow, including an adequate description of evapotranspiration. The model includes processes such as snow accumulation and melting, interception, evaporation and transpiration, capillary rise, and runoff generation. The model parameters, except some land use and soil data, are calibrated with time-series of observed stream flow. The model output consists of daily data of interception, actual evapotranspiration, stream flow and the storage in the various reservoirs.

The MODFLOW model simulates the groundwater flow in a catchment with aquifers and aquitards allowing for recharge, abstractions and drainage to or infiltration from streams (McDonald & Harbaugh, 1988). The input data includes spatial variables such as permeability, storativity, leakage coefficient and stream coefficient. The model also needs time series records of spatially distributed recharge. Stream flow and groundwater level data are used for the calibration.

BILAN and HBVMOR can be applied to all types of catchment (including hard rock), whereas the application of MODFLOW is restricted to catchments with aquifers. BILAN is useful for analysing long time series, whereas HBVMOR can provide a more detailed temporal analysis of a particular short period. MODFLOW can contribute to a better understanding of the spatial and temporal processes involved in streamflow generation over a short time scale. Different types of models are needed because of different objectives, catchment properties, length of time series, and data and computer requirements of HBVMOR and MODFLOW. In this study, the models were used for various purposes and applied to different catchments with different climate and hydrogeology (Table 1).

4 Sensitivity analysis

The sensitivity of drought characteristics to termination (or drought separation) criteria and threshold discharges has been investigated for a range of different catchments and parameter values of the IC and MA criterion using the EXDEV program. Figure 2 shows an example from the Elbe River at Decín (Czech-German border site) where the drought deficit volume with 1% exceedance probability is plotted against pooling criteria and threshold discharge. These results are based on an evaluation of daily flow series from the period 1887-1993 with the threshold level defined as a percentile from the flow duration curve. The IC criterion for pooling droughts is used with both criterion i) and ii) fulfilled,

and the same critical ratio adapted for the interevent time and volume criterion. The three-parameter Log-Normal distribution is fitted to the PDS including all droughts. The figure demonstrates a significant increase in the deficit volume with an increase in threshold level. This illustrates, for example, an increase in the necessary storage capacity of a reservoir to ensure the required reservoir yield. There is also a marked increase in deficit volume with increasing critical values r_c and p_c , particularly for the range 0 to 0.1.

Table 1 : Overview of models, catchments and study objectives

Table 1 : Revue des modèles, bassins et objectifs étudiés

Catchments	Models		
	BILAN	HBVMOR	MODFLOW
Gulp (NL)	c, cl ¹⁾		
Haugland (N)	c,cl		
Hupsel (NL)	c,cl	l	c
Knappom (N)	c,cl		
Monachyle (UK)		l	
Noor (NL)			cl,a
Orlice (CZ)	c,cl		
Rotua (N)		l	
Sæternbekken (N)		c	

¹⁾ stream flow simulation under: c: current conditions; cl: climate change; l: land use change; a: groundwater abstraction

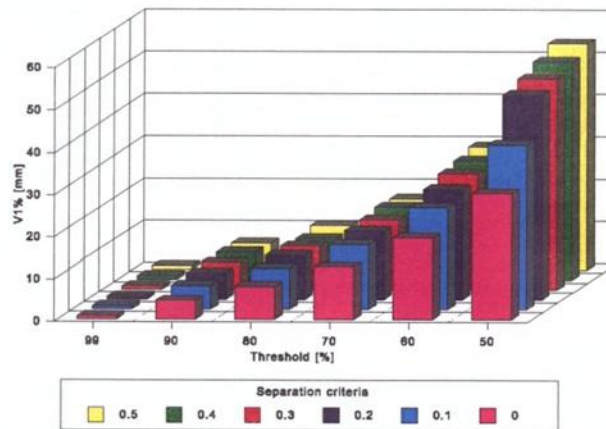

Figure 2 : Drought severity with 1% probability to be exceeded ($V1\%$) versus termination criteria and threshold discharge, the Elbe River at Decin

Figure 2 : Degré de sécheresse à 1% de non-dépassement ($V1\%$), en fonction des critères d'indépendance et de seuil, sur l'Elbe à Decin

Two Danish catchments with very different flow regimes were included in a separate sensitivity study of drought duration and deficit volume (Tallaksen *et al.*, 1997). AMS and PDS of drought duration and deficit volume were derived using three threshold levels, the 50, 70 and 90 percentiles (Q50, Q70 and Q90) of the flow duration curve. Although the two catchments have very different flow regimes, the sensitivity analysis of the AMS of drought duration and deficit volume using the IC and MA methods provided virtually the same results for both catchments with respect to pooling dependent droughts. The «optimal» parameter values (when the sensitivity curves reach a constant or a maximum level) were found for all threshold levels to be $p_c=0.1$ and $t_c=5$ days for the IC method, and $t_c=10$ days for the MA method. This result is consistent with the above conclusions for the Elbe River regarding the critical ratio p_c . The «optimal» values are those which from a water resource engineering viewpoint yield the most critical drought characteristics. For these values the two pooling methods yielded similar

mean values and L-moments statistics of the AMS of drought duration and deficit volume. The results of the SPA method differed significantly from the other two methods for high thresholds due to the presence of multi-year droughts. For analysis of seasonal droughts the SPA method is therefore restricted to low thresholds. However, in the case of very low threshold levels, the occurrence of a large number of years not experiencing any droughts may significantly reduce the information content of the AMS, and in this case the PDS model is superior. The problem of minor droughts in the PDS was implicitly reduced by using the MA and SPA methods, and in this respect these methods have an important advantage as compared to the IC method.

In practical applications, the threshold discharge would normally be related, for example, to the required yield of a reservoir, which could be variable for different water management projects. For regional hydrological studies, a certain threshold should be selected. Statistical analysis of the simulated series performed by the BILAN model (Section 6), aimed at examining the sensitivity of droughts to climatic and hydrogeological parameters, demonstrated that the threshold level Q90 was not suitable. At Q90, different results were obtained from observed and simulated series demonstrating that the model was not sufficiently reliable for identification of droughts. Satisfactory results in terms of the occurrence of droughts, their duration and severity were obtained when 0.5 ADF (average daily flow) was applied as the threshold. These studies have been useful in forming a background (definitions, method and software) for drought analysis, and will form the basis for subsequent temporal and spatial analysis of drought events in Europe in the framework of low flow studies within FRIEND.

5 Regional statistical approach

This part of the study was aimed at assessing the temporal and spatial variation of droughts by analysing flow records. The location, timing, duration and severity of droughts in Europe were the main variables investigated. Three examples of this analysis are presented below.

5.1 South Western Germany

The first example is a study carried out in southwestern Germany which exhibits considerable variability in terms of precipitation, morphology and geology. Using Q90 (the flow exceeded for 90% of the time) as the threshold discharge and the critical ratios of the IC pooling method set equal to 0.1, the annual droughts (in terms of annual maximum duration and severity) were selected for 1962, 1976 and 1991. Basic characteristics of the droughts (onset, duration and severity) were presented in maps to show their spatial and temporal variability.

The 1962 drought began in the majority of catchments either in late summer or autumn (August/September) or during the winter season (December/January). The onset of the 1976 drought was identified for about half of the catchments to be in June/July, while in the remaining catchments the drought began during the period between August or October and January. In 1991, there was an apparent difference between the Danube and Rhine catchments. In the Rhine catchment, the drought started predominantly during July or August, while in the Danube catchment it was later. The onsets of most of the stations for the 1962, 1976 and 1991 droughts did not agree. The droughts in the alpine region show onsets in winter. The onsets not only varied between the three drought years, but also between neighbouring stations.

The 1962 drought, which lasted on average 77 days, was generally more severe than the 1976 and 1991 droughts with average durations of 56 and 43 days respectively. In 1962, the main hydrometric regions (the Danube and Rhine catchments) exhibited identical drought durations (77 days on average), while the 1976 drought lasted 56 days in the Rhine catchment and 30 days in the Danube catchment, and similarly 77 and 34 days in 1991. However for the majority of catchments, the 1976 drought lasted

longer in the northern part of the study area than in the south. This complies with results of a study carried out by the Bavarian Water Authority demonstrating that the drought was more severe in the east Bavarian Mountains than in the Alpine Foreland. Similar results are shown for drought severity.

5.2 Seasonal droughts

Snow and ice affected regions of Europe frequently experience their lowest flows during the winter months. A summer drought is primarily caused by the lack of precipitation, whereas a winter drought is due to precipitation being stored as snow and river discharge reduced by freezing. In order to make a consistent analysis of droughts it is necessary to separate between the two events of summer and winter droughts.

The following example (Figure 3) presents results of a drought analysis, performed on daily flow data observed at 23 sites in Poland for the period 1963-1992. The drought characteristics, particularly the annual maximum duration and severity, were computed for the threshold discharge selected as Q70 using the EXDEV program.

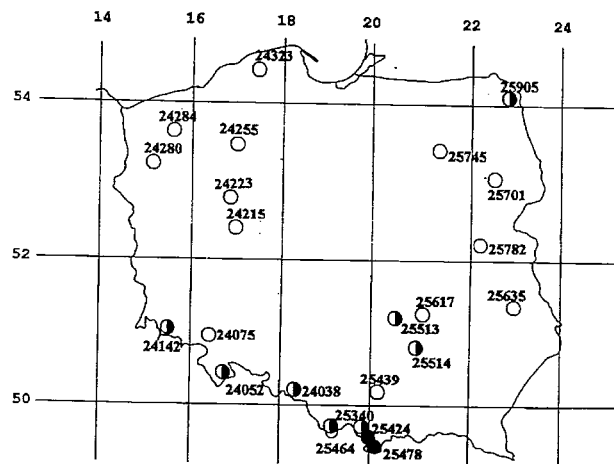

Figure 3 : Spatial and time distribution of drought in Poland (○ summer drought, ● winter drought, ◐ mixed drought)

Figure 3 : Distribution spatiale et temporelle des sècheresses en Pologne ((○ sècheresse d'été, ● sècheresse d'hiver, ◐ sècheresse mixte)

Figure 3 shows the prevalence of winter drought events in the southern-mountainous parts of Poland, the Tatra Mountains, and in the Czarna Hancza Basin located in the northeast. This is attributable mainly to climatic conditions, because during the winter season snow precipitation does not feed the streamflow. At upland basins, such as the Sudethian and the Middle-Upland Basins, the drought can occur any time throughout the year (indicated as a mixed type of drought), while lowland areas are characterized by the most severe droughts beginning in summer and lasting up to late autumn. This type of hydrologic drought is caused by high evapotranspiration during the growing season.

Based on a study of 52 discharge series covering the years 1931-90, the Nordic countries have been classified into four regions; catchments experiencing summer, winter, summer and winter, and all-year droughts (Tallaksen & Hisdal, 1997). To be classified as a summer or winter catchment at least 90% of the droughts have to be within the respective season. The result supports previous regime classifications based on mean monthly flow. AMS of drought duration and deficit volume (using data for the whole year) were derived for the Q70 and Q90 threshold level using moving average 10 day

series. Catchments belonging to the four different regions do not show a clear clustering in L-moments diagrams, however larger L-skewness and L-kurtosis are observed for the mixed summer and winter drought catchments.

By imposing a seasonally dependent threshold level, AMS of summer drought characteristics are defined for all catchments. In general, the variability is high, representing the high variation in flow regime found in the Nordic countries. Because it is difficult to identify homogeneous regions over this diverse landscape the number of stations is low. However, there is a clear tendency that the range of values are reduced when the geographic region is restricted. The three parameter generalized Pareto distribution in general gives the best fit to drought duration and deficit volume when all stations are considered.

5.3 Spatial variability of drought

The spatial variability of drought can be mapped by expressing monthly runoff in mm. Whilst adequately displaying the relative magnitude of runoff during droughts, it does not illustrate the relative frequency of droughts in different regions. This can be achieved by mapping the exceedance probability of droughts by analysing daily discharge data.

The method is illustrated in Figure 4 and consists of :

- 1) Retrieving the observed daily flow time series from the European Water Archive.
- 2) Deriving the flow duration curve (cumulative frequency diagram) from the observed data.
- 3) Transforming the daily flow time series to a daily exceedance series using the observed daily flow duration curve.

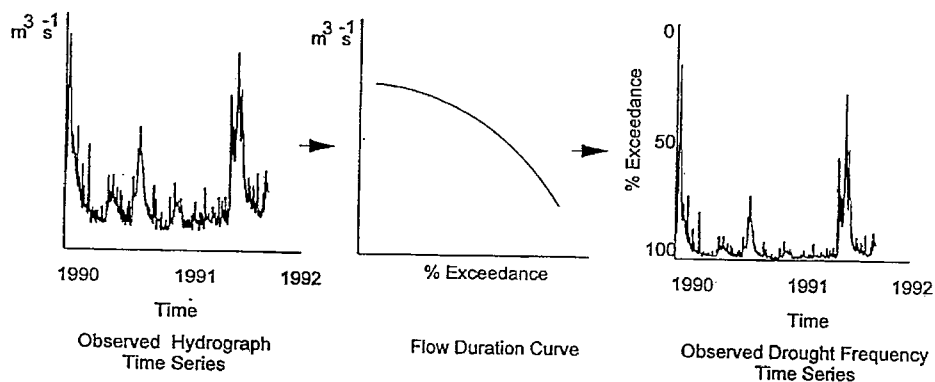

Figure 4 : Deriving time series of drought frequency

Figure 4 : Obtention des chroniques de fréquences des sécheresses

This will produce a continuous drought time series expressed as the percentage of time a given discharge is exceeded for every day of record. The frequencies are then mapped at the European scale to estimate the spatial variability of drought frequency.

A program has been written to convert daily flow values into exceedance percentiles accessing the European Water Archive. Individual catchments have been colour coded to represent the exceedance frequency ranging from dark blue (high flows, low exceedance) through green, yellow, orange and red for low flows, high exceedance. Although the procedure is simple for individual catchments, nested catchments present problems in displaying the data adequately. The approach which has been used is to

shade the polygon of an upstream catchment according to its exceedence value. The polygon of the residual catchment area between the upstream and next downstream gauging station is allocated the exceedence value of the downstream flow record.

Using this approach, an initial set of maps have been produced for European catchments illustrating the development of the 1976 drought from February to August. From a relatively uniform frequency map in February, a wide range of frequencies are experienced in April and June with extreme conditions experienced over nearly the entire region in August. Contrasting examples are shown in Figure 5 from the relatively high flows experienced on 10 March 1976 to the very low flows of 10 August 1976. This large scale analysis is appropriate for considering the climatic impact on the spatial coherence of droughts at the European scale. However, it is not suitable for analysing the more localised control of catchment response and hydrogeological properties. This was achieved by studying how the exceedence values vary within nested catchments.

One of the weaknesses of the above approach is to allocate the downstream exceedence percentile to the upstream residual area in the nested catchment case. Clearly the downstream exceedence should be allocated to the entire upstream catchment area or the residual flow exceedence should be calculated and allocated to the residual catchment area. This can be determined by deriving a new time series of flows from the difference between the up and downstream time series and deriving percentile exceedences from this new series. To compensate for river routing the analysis can be carried out on a seven day moving average. In practice this approach has proved difficult as a result of gaps in time series restricting the ability to derive residual flow series. Two procedures have been adopted; the first is to use only matching flow sequence, the second is to infill missing data. For the regional European synoptic analysis the advantages of more accurate illustration of observed frequencies are small. However, for analysis and deriving relationships with thematic data there are clear advantages of a more realistic spatial analysis of nested catchments. It is an interesting feature of this study that a small data set without nested catchments is easier to analyse. The addition of more data introduces computational and display problems. Residual catchment flows estimated from the difference between up and downstream gauges have larger errors than the individual station data. In this case the addition of this extra data leads to an apparent increase in spatial variability as a result of increased errors of derived time series. An additional advancement of the technique is to use monthly flow duration curves instead of annual curves in order to determine exceedence frequency on any day.

6 Physically based modelling approach

In this section some results of the BILAN, HBVMOR and MODFLOW model simulations are presented to demonstrate the potential of the physically based modelling approach and to examine the main factors contributing to the duration and severity of droughts. Moreover, the impact of some human interferences (climate and land use change, groundwater abstraction) are analysed.

The BILAN model studies were aimed particularly at examining the main hydrological factors contributing to droughts. Time series of stream flow, precipitation and air temperature were examined together with the model output, mainly the catchment groundwater and snow cover storage. As demonstrated by the following four examples, the analysis identifies the main factors responsible for droughts in a particular catchment.

The first example (see Figure 6) is the Haugland Catchment (135 km²) situated on the western coast of Norway. The mean annual catchment precipitation is high (1820 mm), but the groundwater storage capacity is low and thus monthly precipitation and runoff are closely related. This close relationship also exists in the winter season because of the low snow water storage. The coastal climate (mean annual temperature of 7.4°C) prevents large snow accumulation. Under such conditions the runoff regime reflects the precipitation and evapotranspiration regime, resulting in similar hydrological and meteorological droughts.

The Knappom Catchment (1625 km²), is located in the eastern part of Norway. This results in a substantially lower annual precipitation (790 mm) and a lower mean annual temperature (2°C) than the Haugland catchment. The snow cover, which accumulates normally between November and March, melts during March to May, feeding stream flow, which rises significantly (see Figure 6). The rising limb of the hydrograph, because of snow melt, is followed by decreasing stream flow during the summer until the autumn, when higher precipitation together with low potential evapotranspiration are normally observed. During the winter season, when the surface runoff component of stream flow ceases, a drought usually occurs, whose severity is closely linked with the amount of groundwater storage accumulated from precipitation during the summer and particularly the autumn season.

In contrast to the Nordic basins, the groundwater storage capacity of the Gulp Catchment (46 km²), situated in the southern part of the Netherlands, is high (see Figure 6). The capacity amounts to several hundreds of millimetres and can store a substantial part of the annual precipitation of 765 mm. Such hydrogeological conditions are reflected in low stream flow response to variability in antecedent precipitation. Although long meteorological drought periods result in low stream flows, short meteorological drought periods are not reflected in river flow. This was demonstrated by the 1990 drought, which occurred after a long precipitation deficit period lasting for two years. This example also shows the advantage of the modelling approach for identifying the physical controls on drought response to precipitation.

The Orlice River Catchment covering an area of 1591 km² is situated in the Czech Republic. This basin has a mean annual precipitation of 860 mm and the groundwater storage capacity is significant but not extremely high. Summer precipitation exceeds winter precipitation. The annual minima of the stream flow, however, are usually reached during the summer season, because evapotranspiration is still higher than the precipitation, which results in a decrease of stream flow (see Figure 6). The most severe drought occurs when a dry summer and autumn is followed by a winter season with temperatures below 0°C. The winter precipitation accumulates as snow and does not contribute to stream flow and the drought event can continue until snowmelt in the spring. The drought can last eight months. Under such conditions, a combination of three factors are relevant - long-term precipitation deficit associated with groundwater storage state, summer and autumn precipitation, and winter temperature.

The BILAN water balance model has been applied to several catchments in different countries (Table 1) and this demonstrated that climatological conditions play a key role in the duration and severity of droughts. In catchments with an impermeable geology or a low groundwater storage, meteorological droughts and low flows are closely related. Short-term aspects are clearly visible. On the contrary, groundwater dominated catchments only reflect long-term precipitation deficit periods.

The HBVMOR model was applied to catchments in three different countries with different climate and hydrogeology (Table 1) to explore the effect of land use change on stream flow. In the Hupsel, Monachyle and Rotua catchments stream flow was simulated for 0 and 100% forest cover. Afforestation suggests a decrease in the mean flow and a downward shift in the flow duration curve. The percentage change in the mean flow for annual periods is highest in the Hupselse Beek catchment, i.e. 29%, because of the low mean flow. In the Monachyle and Rotua catchments, this change is smaller, about 4%. Care should be taken when interpreting these results because of the model description of the snow interception and evaporation processes for different vegetation types (Tallaksen & Erichsen, 1994; Tallaksen *et al.*, 1996).

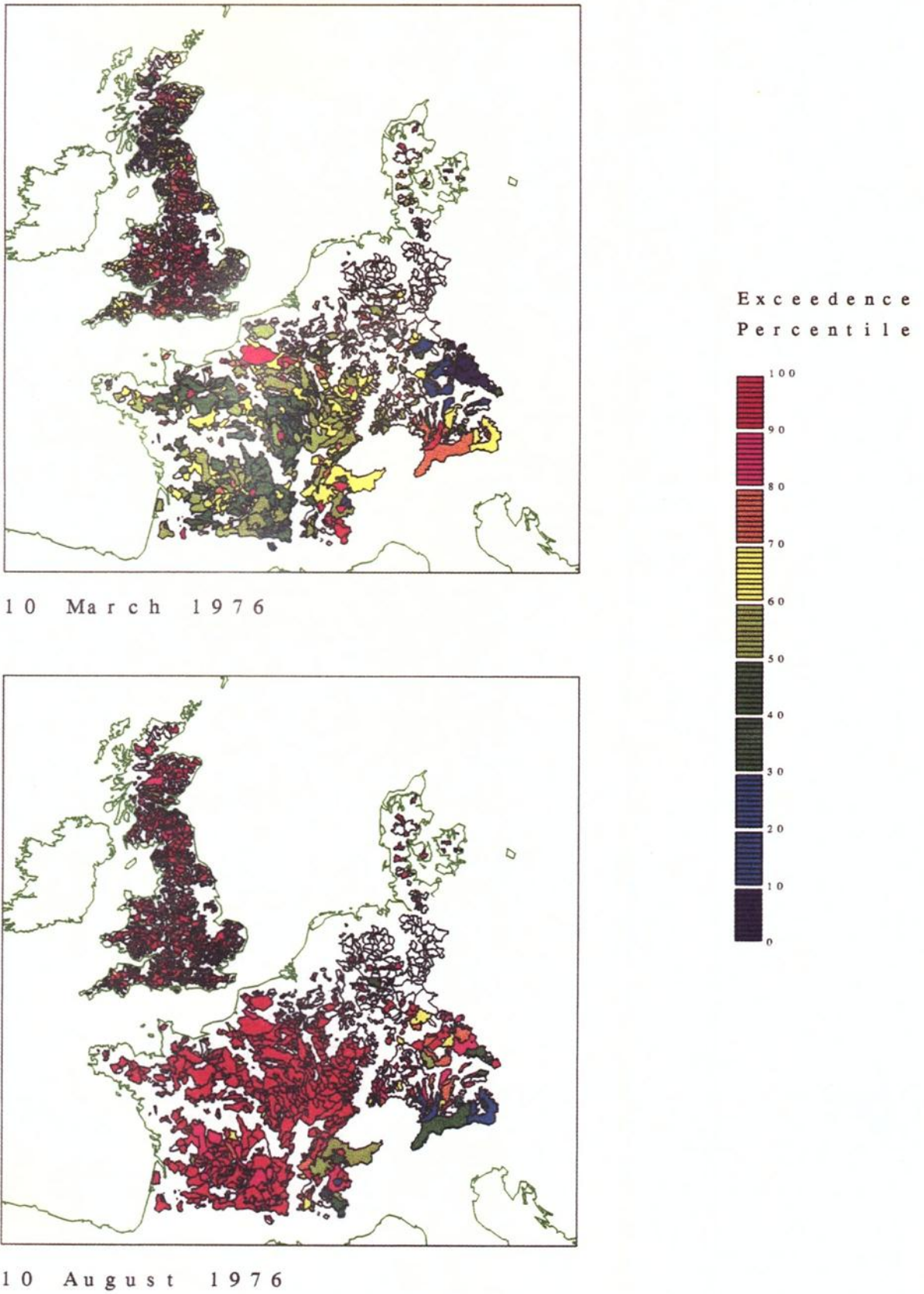

Figure 5 : Exceedence percentiles for European catchments on selected dates in 1976.

Figure 5 : Quantiles (en %) au dépassement, pour une sélection de bassins européens, en 1976

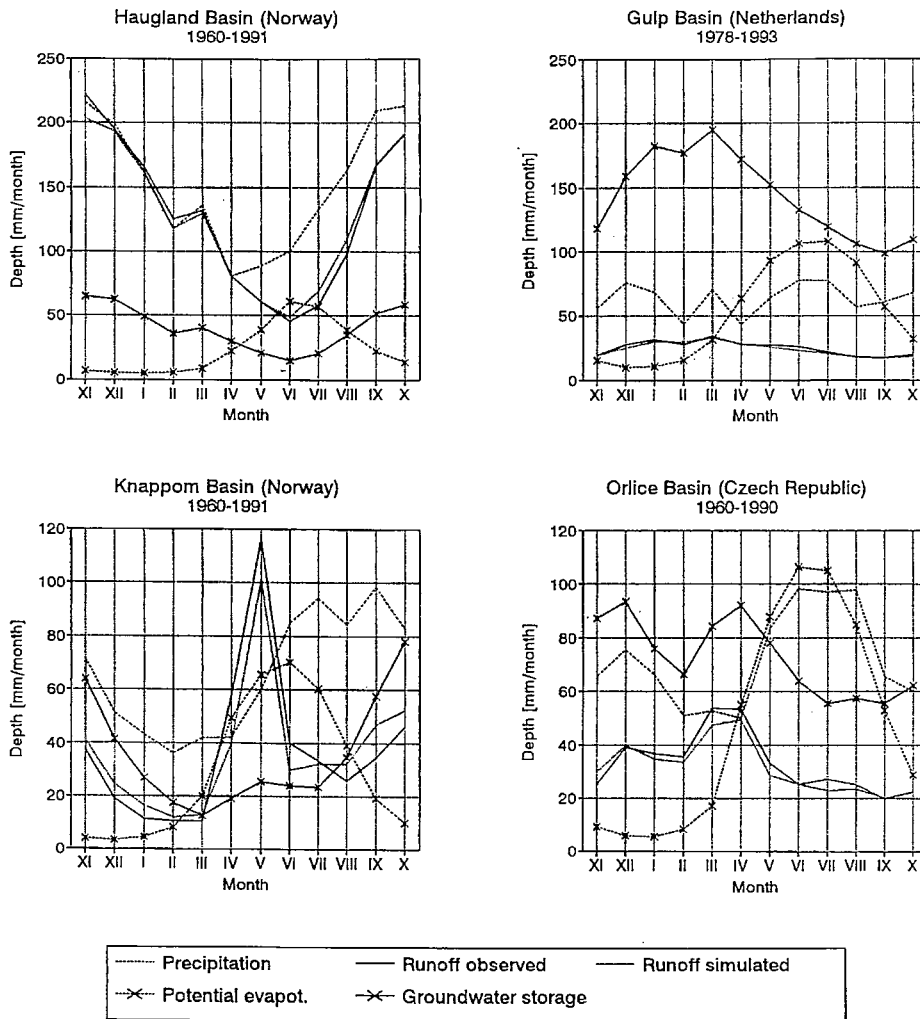

Figure 6 : Average water balance terms simulated by the BILAN model
Figure 6 : Simulation des termes majeurs en bilan pour le modèle BILAN

The MODFLOW model was also applied to the Noor Catchment to explore the effects of groundwater abstraction scenarios on stream flow (van Lanen & van de Weerd, 1994; van Lanen *et al.*, 1995). The example given below shows the effect of the groundwater recharge and groundwater abstraction on the spring flow regime using data for the St. Brigida spring, which is the main spring of the Noor (the Netherlands). During the period 1988-1994, the spring with a maximum yield of 42 ls⁻¹ dried up for a long period in both 1991 and 1992. The spring dried up for 615 days (about 25% of the time), which was very unusual because historical reports indicated that the spring has been dry only a few times this century.

In order to separate the natural drought (precipitation deficit) from man-induced impacts (groundwater abstraction, and land use change or climatic change resulting in a lower or higher groundwater recharge), the MODFLOW model was used to simulate the following scenarios: a 20% higher (120% recharge) and a 20% lower groundwater recharge (80% recharge). Groundwater abstraction scenario I represents a further increase in the abstraction by 1.10⁶ m³/year, as was requested by the drinking water supply company. Abstraction scenario II assumes termination of all the groundwater abstractions from the Margraten Plateau. Spring flow series simulated for the existing and potential conditions were analysed using the EXDEV software (Ricina & Novický, 1995). Some results are presented in Figure 7.

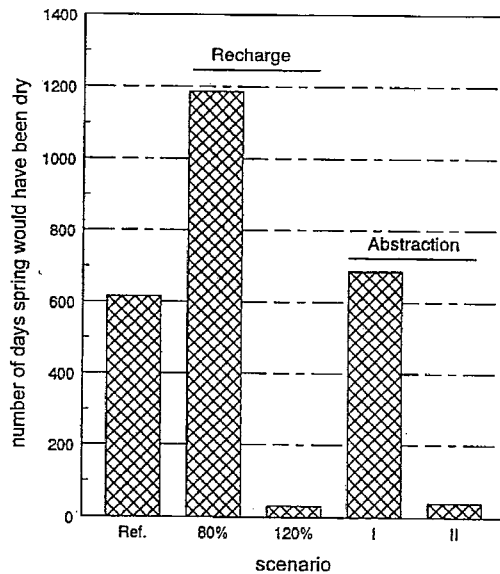

Figure 7 : Impact of groundwater recharge and groundwater abstraction on the flow of the St. Brigida spring

Figure 7 : Impact des recharges de nappes et des prélèvements, sur l'écoulement de la source St Brigida

The simulation demonstrated that small changes in the groundwater recharge induced for instance by climate or land used change, have a significant effect on the number of days that the St. Brigida spring would have been dry in the period 1988-1994. A decrease of the recharge by 20% nearly doubles the number of days, whereas an increase by 20% would result in a spring which would be dry for a very short period of time (about 2%). A limited increase in the groundwater abstraction from the Margraten Plateau (scenario I) increases the number of days the St. Brigida spring is dry by only 11%. The relatively large distance between the well field and the Noor Catchment is the main reason for this small increase. If all the abstractions were stopped, the average spring flow would not change by more than 0.12 ls^{-1} (a decrease of 1%). Termination of all groundwater abstractions would result in an effect similar to an increase in the groundwater recharge of 20% (a dry St. Brigida spring in about 2% of the days). Although the decrease in average spring flow is small the decrease in the number of days with zero spring flow from 25% to 2% is remarkable.

7 Complementary approaches: estimation of MAM(10) by multiple regression

7.1 Analyses

One of the studies, carried out within the FRIEND project, was aimed at estimating MAM(10) by using a multiple regression approach. The classical application of multiple regression models in hydrological studies leads to the estimation of flow parameters of single river systems. In contrast to the classical multiple regression approach a river network regression approach was adopted (Figure 8). As the gauging stations of the present study contain catchment areas with a maximum size of 500 km^2 and thematic data based on maps with scales between 1 : 500 000 and 1 : 1 000 000, the combinations of thematic data close to the gauging stations are almost similar to the combinations within the catchments. The MAM(10) of the stations were related directly to the thematic data of areas upstream of the gauging station by dividing the river network into five 1 km sections. The properties of $1 \times 1 \text{ km}$ areas along these sections were then related to the calculated MAM(10). This modified regression approach leads to the estimation of the MAM(10) for all combinations of thematic data within the river network area. If the attribute combinations of the river network areas describe those of the study area,

the regression model can be applied to the entire study area.

The data base included 170 gauging stations with daily flow records of between 10 and 60 years in length. The MAM(10) varied considerably. A case study was carried out in the State of Baden-Wuerttemberg in Southwest Germany. The mean specific MAM(10) of the study area is $5.0 \text{ l s}^{-1} \text{ km}^{-2}$. The highest values are found in the mountainous catchments of the Voralpen ($19.1 \text{ l s}^{-1} \text{ km}^{-2}$) and the north of the Black Forest ($8.4 \text{ l s}^{-1} \text{ km}^{-2}$) where climatic factors prevail. High annual rainfall cause high values of low flows and other factors, such as storage capacities are less important. Especially in the Black Forest and the Pre-Alps with mean annual rainfall of more than 1 000 mm, MAM(10) increases. The lowest values are calculated for catchments of the Keuper Bergland ($0.9 \text{ l s}^{-1} \text{ km}^{-2}$) and the Swabian Alb ($1.0 \text{ l s}^{-1} \text{ km}^{-2}$) with different geology and annual rainfall varying between 600 and 900 mm. Relatively low mean MAM(10) are found in catchments situated in the centre of the study area e.g. in the regions of the Swabian Alp, Pre-Alb and the Gäulandschaften.

Since a multiple regression model is only valid for application within the range of calibrated data, combinations of attributes (geology, hydrogeology, petrography and landuse) in the study area were calculated. These combinations were compared to the combinations of the areas upstream of the gauging stations. In addition all combinations which are not represented by the areas upstream of the gauging stations are indicated. For example, within the study area, 1000-5000 km^2 have Tertiary strata (geology) with low groundwater capacity (hydrogeology). In the river network areas of the gauging stations this combination is not available. Only about 9% of the total study area was not described by the thematic data of the river network areas of the gauging stations. Finally the thematic data were dummy coded and a multiple regression model was adopted to estimate the MAM(10) within the study area (Figure 9). The combinations of thematic data which are not represented by thematic data of the river network areas of the gauging stations are marked.

7.2 Results

The geology appears in the regression equation as the most important explaining variable, hence the estimation of specific MAM(10) follows in general the distribution of the geological classes. Highest values of specific MAM(10) are estimated in the Voralpen and in the Schwarzwald. Relatively low specific MAM(10) values are located in the Gäulandschaften and the foreland of the Schwäbische Alb. In general this estimation of MAM(10) follows the calculated specific MAM(10) of the gauging stations. The hydrogeological properties and land use are significant in explaining the variance of MAM(10) in southwest Germany. The coefficient of determination is 56%. A comparison with earlier studies in the same region with the catchment approach shows that the new approach leads to satisfactory results (Wesselink *et al.* 1994, Demuth & Hagemann 1994).

The analysis of the residuals showed an even distribution of the values, which indicates that the model chosen was appropriate. Figure 10 summarises the residuals of each station. Every gauging station is plotted together with the calculated and the estimated MAM(10) and the quality of the estimation. The evaluation of the model leads in 19% of the gauging stations to very good results with residuals up to 10% of the calculated MAM(10). 33% of the gauging stations have good results with an estimation error between 10% and 30%. 27% of the gauging stations show satisfactory estimations, with errors up to 50%. The remaining 21% of the gauging stations are poorly estimated. In this region the variation of geology, hydrogeology, petrography and landuse does not describe the variation of MAM(10).

An alternative regionalisation approach was based on an analysis of Slovak catchments using a factor analysis method. In addition to flow data, catchment characteristics, such as the location of the catchment with respect to the geomorphological classification of Slovak territory, hydrogeological characteristics of rocks described by their stratigraphical age, rock type, permeability (fissure, karst, pore or combined), transmissivity ($\text{m}^2 \text{ s}^{-1}$), and specific yield ($\text{l s}^{-1} \text{ m}^{-1}$), were used. All characteristics were derived from basic hydrogeological maps of Slovakia at a scale 1:200000. The analysis resulted in interrelationships between physiogeographic catchment characteristics being defined and in the

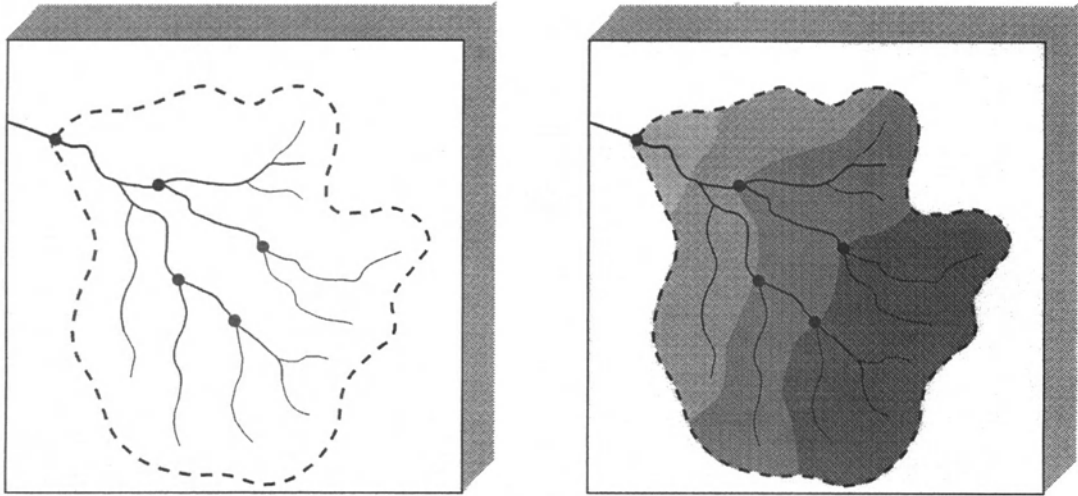
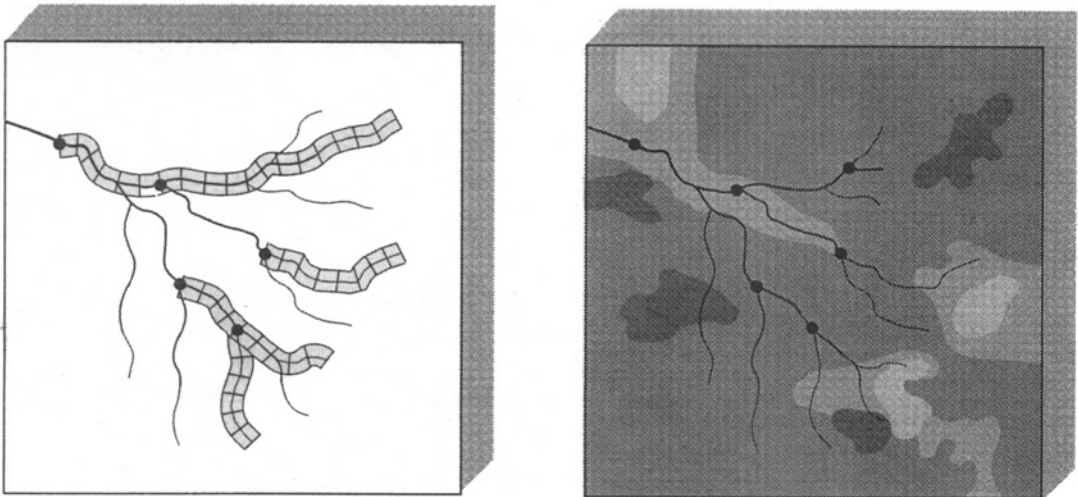
(a) Classical multiple regression approached based on individual catchments*(b) Modified multiple regression approached based on the river network***Figure 8 :** *Comparison between different regression models***Figure 8 :** *Comparaison entre différents modèles de régression*

catchments being classified into two groups with respect to the factors responsible for minimum runoff formation. Streamflow recession analysis has also been found to be a useful tool for quantitative estimation of that part of the total runoff fed from ground water storage and thus also for the analysis of drought events. Theoretical approaches and application of recession models were reviewed in Demuth & Schreiber (1994), Singh (1989), Tallaksen (1995). A recession model based on Maillet's equation was used in other studies (Radczyk & Szarska (1989), Kupczyk *et al.* (1994)) and the derivation of low flow distribution function using recession curves presented in Gottschalk *et al.* (1977).

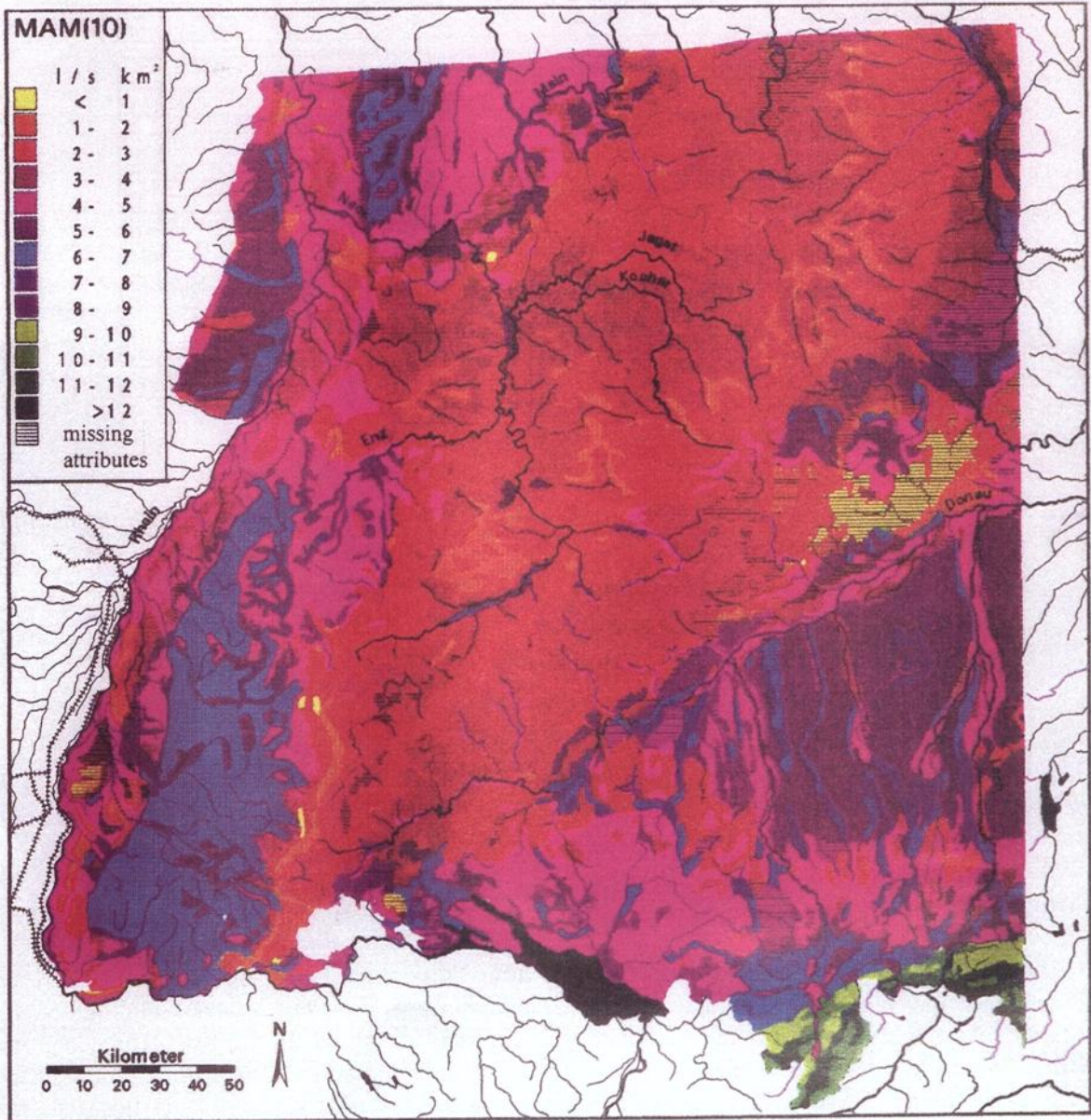

Figure 9 : Estimation of specific MAM(10) in Southwest Germany with a river network approach
Figure 9 : Estimation du MAM(10) spécifique, moyenne du débit-volume de 10 jours mVCN10, dans le Sud-Ouest de l'Allemagne, avec une approche arborescente le long du réseau

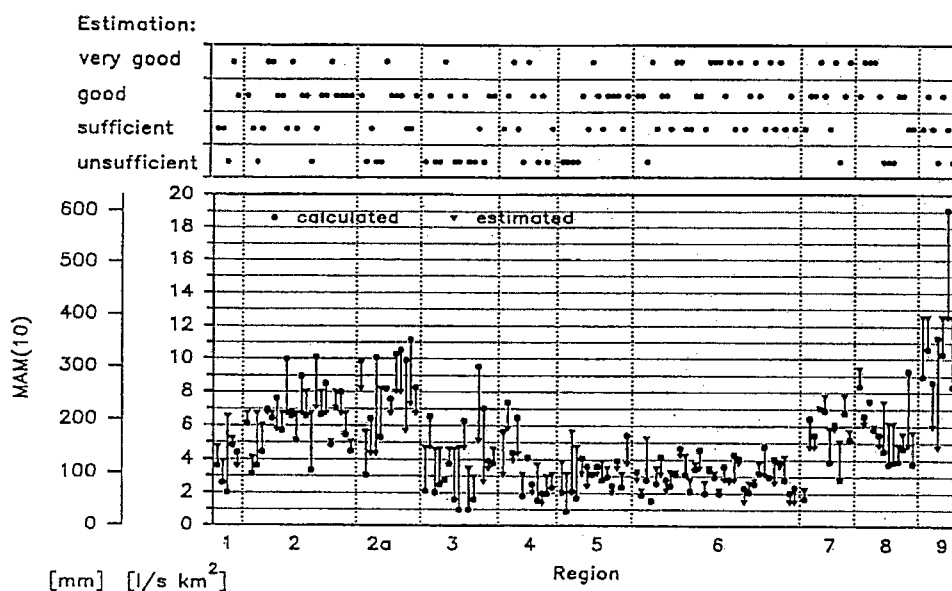

Figure 10 : Residuals of the estimation of specific MAM(10) in Southwest Germany with the multiple regression model

- | | |
|----------------------------------|---------------------|
| 1 : Oberrheinische Tiefebene | 5 : Keuper Bergland |
| 2 : Schwarzwald and Odenwald | 6 : Gäulandschaften |
| 2a : Nord-Schwarzwald | 7 : Altmoränenland |
| 3 : Schwäbische Alb | 8 : Jungmoränenland |
| 4 : Vorland der Schwäbischen Alb | 9 : Voralpen |

Figure 10 : Résidus de l'estimation du MAM(10)/mVCN10 dans le Sud-Ouest de l'Allemagne, avec le modèle de régression multiple.

8 Conclusions

This chapter has described methods for defining drought severity based on the threshold level approach, the flow duration curve and the annual minimum series. The analysis highlighted the sensitivity of drought severity to the termination criteria and threshold discharges. Three regional statistical approaches described a range of techniques for evaluating the location, timing, duration and severity of droughts. These methods were based on the analysis of time series of daily flow data and can be applied anywhere in Europe and are particularly suitable when combined with Geographical Information Systems for the analysis and display of data. In order to assess the sensitivity of droughts to environmental change it is necessary to use a physically based modelling approach. This can enable the impact of change in climate, land use or groundwater abstraction on river flows to be estimated. Three models were applied in nine European catchments and a number of environmental change scenarios were included.

The MAM(10) analysis has illustrated that the modified multiple regression approach on the river network is appropriate to develop a regional design procedure for estimation at the ungauged site. Although the model produces satisfactory estimation results in comparison to earlier studies, some stations are poorly estimated because in some regions the hydrogeological properties cannot describe the local low flow response. The low flow investigations illustrated the benefits of analysing large regional or pan European time series of daily flows for estimating flows at ungauged sites and for describing the growth and decay of European droughts. However, in order to understand the physical controls on low flow response and to be able to predict the impact of environmental change it is essential that a physically based modelling approach is used.

Regional water resources and drought assessment in Southern Africa

Estimation des ressources en eau et des sècheresses en Afrique Australe

A. Bullock, T. Andrews and R. Mngodo

Introduction

The Southern African FRIEND region embraces a transect of African climates from the humid tropical regions of Tanzania, through the transitional sub-humid and semi-arid regions to the arid Kalahari desert of Namibia, Botswana and South Africa. This variety of climatic regimes, combined with complex associations of geology, soil, vegetation and wetlands, results in the region being characterised by diverse river flow regimes. These different flow regimes are represented by the set of 676 daily flow series contributed by the eleven participating countries. The Southern African programme has included a "Regional water resources and drought assessment" project, of which a full report is included within the Southern African FRIEND report. This component project, contributing to the overall Southern African FRIEND programme, has been coordinated by the Institute of Hydrology (UK) and the University of Dar es Salaam (Tanzania). This contribution to the 3rd General FRIEND report presents a sample of project results relating to mean annual runoff, flow duration curves and drought.

Mean annual runoff

Mean annual runoff (MAR) is a fundamental hydrological variable with applications in national and international water assessments and in the planning and development of water resource-based schemes (e.g. irrigation, hydropower, forestry). In addition, low flow analyses are traditionally undertaken in standardised terms (that is, low flow data series are standardised by mean flow). In order to remove the scale effects of basin area and effective rainfall between a large number of catchments in a regional data set. Consequently, the estimation of mean flow, derived from MAR, at ungauged sites is an integral step in low flow analysis as a means to convert standardised low flow estimates to absolute (i.e. flow) terms.

Amongst the eleven countries, emphasis has been given to MAR estimation in past studies (one example for each country is presented in Table 1). With the exception of Angola and Tanzania, nine countries have regionalised MAR as observed at gauged sites to estimate MAR within nationally-defined water resource planning zones. Different methods of regionalisation have been adopted amongst the countries, ranging from standard unit runoff mapping to the application of rainfall-runoff models with regionalised parameters. Furthermore, adoption of different methods introduces variations into the nature of the regionalised MAR; rainfall-runoff models have simulated MAR under naturalised 'virgin' conditions while standard unit runoff mapping approaches (without prior naturalisation) represent MAR estimates which are artificially influenced by man. While recognising the adoption of different methods and variation in the estimated MAR, a Southern African MAR coverage (Figure 1) has been constructed which combines, while retaining, the different national estimation procedures (adopting those studies listed in Table 1). The MAR coverage (simplified here for presentation purposes into classes of MAR in mm) includes estimates for 688 nationally-defined water resources planning zones, unified in their numbering by the FRIEND international scheme. The structure of the numbering scheme and the application of the GIS REGION function enable previously complex but now rapid retrievals such as (a) MAR of the Zambezi river, (b) MAR of Zimbabwe, (c) MAR of the Zambezi within Zimbabwe (d) MAR of the Zambezi upstream of Zimbabwe, all based on past national studies.

Table 1 : National mean annual runoff estimation procedures in Southern Africa

Table 1 : Procédure d'estimation nationale des modules d'écoulement (mQA) en Afrique Australe

Country	Reference	Basis of national water availability study
Ang.	Neto & Mendes (1996)	Flow regimes of 22 major rivers, without national regionalisation
Bot.	SMEC et al., 1991	Regionalised monthly Pitman and Monash models.
Les.	WRC (1994)	see South Africa
Mal.	Dpt. of Water (1986)	MAR isolines to estimate MAR in 17 Water Resources Areas
Moz.	DNA (1994)	MAR based on internal and external gauged data
Nam.	DWA (1992)	National unit runoff map
RSA	WRC (1994)	WRSM90 'virgin' MAR for quaternary sub-basins
Swa.	WRC (1994)	See South Africa
Tan.	Min. of Ener. (1995)	Rapid resource assessment, without national regionalisation
Zam.	JICA (1995)	Unit runoff estimation of MAR in 34 basin 'blocks'
Zim.	MWRD (1984)	MAR for 152 hydrometric sub-zones, transferred from gauges

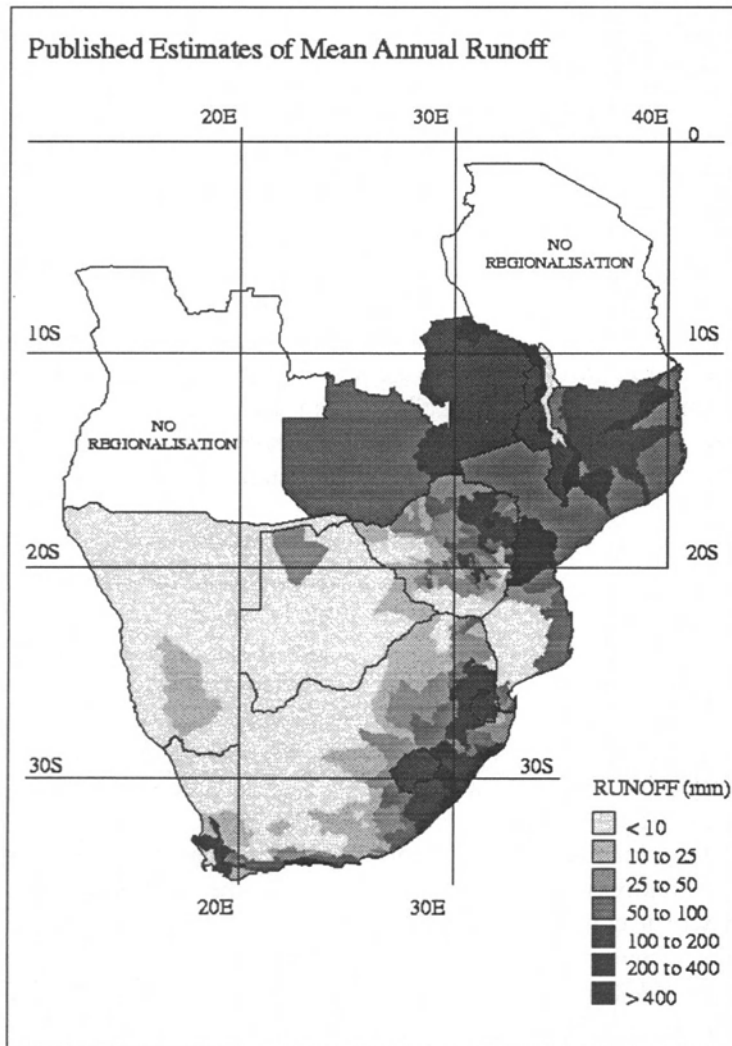

Figure 1 : Mean annual runoff for Southern Africa, integrating national estimation procedures

Figure 1 : Ecoulement annuel moyen (mQA) en Afrique Australe, avec les estimations des procédures nationales

With the twin objectives of first understanding the spatial variability of MAR, and second evolving a procedure for estimating MAR in a regionally consistent manner, the Southern African FRIEND project has applied a variety of different water balance and grid-scale modelling techniques. These have met with varying degrees of success. Relatively simplistic water balance methods, using either annual or monthly rainfall and evaporation data, have difficulties in explaining the wide variability of observed MAR for a given rainfall depth. Empirical methods, such as Budyko and Turc-Pike, are limited in their applicability because they predict the ratio of actual to potential evaporation within a range which is very limited relative to derived values of the ratio for gauged catchments.

The most complex of the water balance simulations has been the application and validation of a grid-based rainfall-runoff modelling technique. Based on a regular 0.5° longitude by 0.5° latitude grid, each grid cell is simulated as an independent catchment. The model used is a conceptual rainfall-runoff model, based on Moore's (1985) probability distributed model (PDM), with the parameters predetermined from physical and climatic characteristics, rather than by calibration. With evapotranspiration and interception losses determined by the catchment forest and wetland coverage, the model comprises two stores: a soil moisture store and a groundwater store. Driven by daily rainfall (disaggregated from monthly time series using knowledge and assumptions of the number and sequencing of raindays) and daily potential evaporation (disaggregated from monthly long-term averages), the model applies a simple daily accounting procedure for each cell on each day :

$$S_t = S_{t-1} + P_t - Ae_t - Q_t - D_t$$

The soil moisture content on the current day (S_t) is calculated as a function of S_{t-1} , rainfall (P_t), and actual evaporation (Ae_t). S_t is reduced by direct runoff (Q_t) when the soil store is saturated, and by drainage from the soil into the groundwater store (D_t). Flow generated within the cell is determined as a function of Q and D_t , such that when the entire cell has reached capacity.

$$Q_t = (P_t - Ae_t - D_t) - (S_{max} - S_t)$$

where S_{max} is the maximum amount of water that may be held in the soil.

Actual evaporation on any given day (Ae_t) is calculated as a function of interception losses and potential evaporation, whereby the actual rate is considered to be equal to the potential rate until field capacity is reached, thereafter declining linearly to zero. Model parameters, such as forest cover, S_{max} and field capacity are predetermined from soil properties and the distribution of forest and soil types within GIS coverages. The model is run independently for each cell in the region for the 30-year period between 1961 and 1990, generating grid-cell based time series of daily runoff for that time period.

The simulated flow sequences for each grid cell can be resampled to derive flow measures, including such volumetric indices as MAR and mean monthly flows and such indices as annual and monthly flow variability and reliability. Presenting an image of a common flow measure for all grid cells in Southern Africa provides a regional overview of the spatial distribution of flow measures. Figure 2 represents a grid-based simulation of MAR based on an application of the modified PDM model. This approach offers a potential advance in MAR estimation in Southern Africa by applying a single method across the whole region, unlike the combination of different methods in Figure 1.

As the parameters of the PDM model are not calibrated and optimised against observed flow series, it is important that model outputs are validated against observed flow measures. The combination of a regional application of the model within a diverse combination of climatic, forest and soil characteristics and the large set of observed FRIEND flow data which represent that diversity offers an excellent opportunity to evaluate the performance of this type of model in different environments. Validation of the model has taken two forms; first, an investigation of the sensitivity of model outputs to each of the individual inputs and model parameters, and second, a comparison of observed and simulated outputs. Limiting this discussion to the latter, Figure 3 demonstrates a comparison of

observed and simulated outputs (for a common data period), in which each data point represents a gauged FRIEND flow station (simulated catchment values were derived by superimposing catchment boundaries onto the simulated grid coverage). Each data point is categorised by a climate index, representing a spectrum from arid (Climate Type 1, with no months in which rainfall exceeds potential evaporation) to humid (Climate Type 6, with close to 12 months in which rainfall exceeds potential evaporation, and the depth of effective precipitation is over 50% of total rainfall). This comparison identifies a wide degree of scatter in the relationship between simulated and observed catchment values. Apparent within the data is a clear tendency in the model, as currently set up, to underpredict in the more arid zones (Climate Types 1-3) and to overpredict in the more humid zones (Climate Types 4-6). A sensible explanation for underprediction in arid zones would be the model requirement that soil moisture deficits are satisfied throughout a 0.5° longitude by 0.5° latitude grid prior to runoff generation, whereas runoff generation in arid zones is predominantly by localised infiltration-excess mechanisms. In the humid zones, there is no such obvious explanation, but the model needs to lose more water to evapotranspiration processes. Such consistent tendencies displayed by the comparison against observed data suggest a need for reconsideration of the runoff generation algorithms in order to improve the model performance under the range of climatic environments within Southern Africa. Only when such modifications are accomplished, and simulations reasonably approach observed data, can such a model can fulfill the potential which might be offered by a regional MAR simulation model. One likely fruitful area for model development is a move away from a grid-based application towards GIS 'Region'-defined complexes of similar vegetation, soil and hydrogeology.

In anticipation of the future evolution of improved and consistent regional MAR simulation procedures, the FRIEND project has developed the capability to accumulate grid-based MAR values using an available Digital Terrain Model (DTM). The underpinning principle is that it is possible with GIS technology to simulate the outflow direction for each grid cell of the DTM, by relating the altitude of any given cell to the altitude of the 8 adjacent cells to determine one of 8 possible outflow directions. By applying this algorithm to each cell, it is possible to construct flow directions from headwater to river mouth across the whole of the Southern African region.

Overall, the work undertaken on the spatial variability of mean annual runoff so far suggests that there remains considerable scope for advancing the consistency, the process understanding and the regional water balance estimation in Southern Africa beyond that which has been initiated and so far accomplished by the FRIEND project. It is foreseen that advances in the scientific methods, combined with the extensive data sets for calibration and validation, and the retrieval routines (based on national water resource planning zones and the regional DTM) will offer substantial advances in national and international water resource assessments. Such assessments provide a hydrological foundation into policy formulation in spheres such as irrigation planning, commercial forestry and international river basin agreements.

Base flow regimes

There are a variety of different methods which can be applied to hydrograph separation of long time series, a selection of which have been applied in past studies in Southern Africa. However, it is rare that different methods are applied to the same data series to enable a comparison of the results from different methods. Table 2 presents estimates of BFI (Base Flow Index - being the proportion of total runoff considered to be base flow) using three different hydrograph separation methods (two of which originate from Smakhtin and Watkins (1997)) for five catchments in South Africa. The 'filter' method applies a digital filter which separates "high-frequency" quickflow from the original streamflow; the 'rational' method is based on interpolation between nodal point in the hydrograph identified by recession analysis; the 'turning point' method is based on interpolation between criterion-based inflexions in the long-term hydrograph.

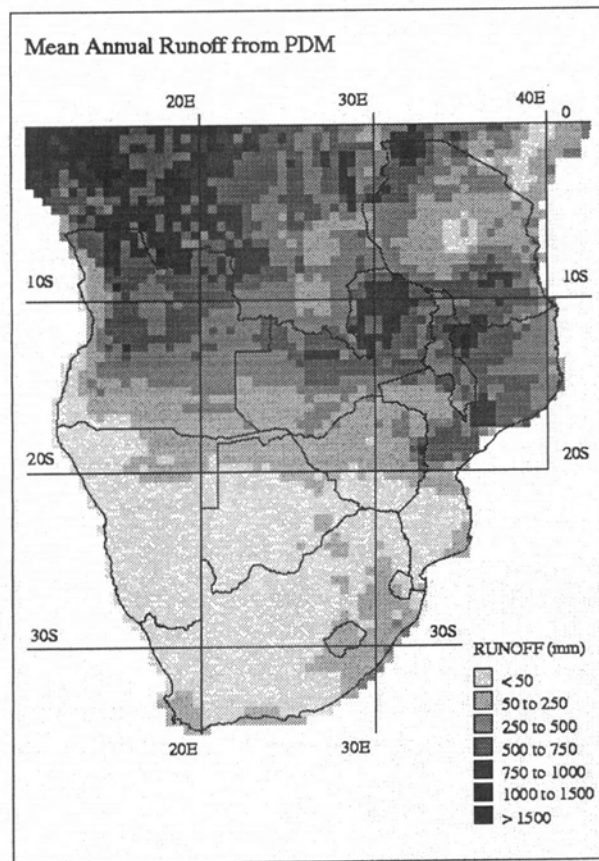

Figure 2 : Grid-based simulation of MAR using the modified PDM model

Figure 2 : Estimation maillée de l'écoulement annuel moyen MAR/(mQA), exploitant le modèle PDM modifié

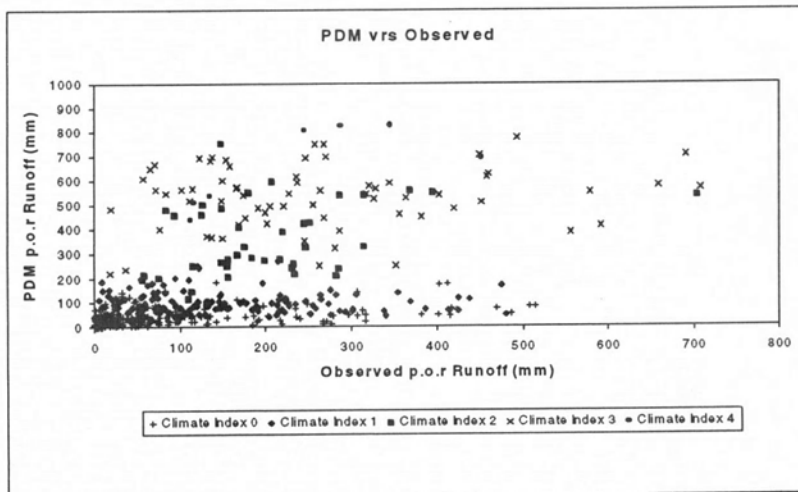

Figure 3 : Validation of the grid-based simulation against observed flow data, with catchment values categorised by climate type (Climate Type 1 being the most arid and Climate Type 6 being the most humid, with increasing and more evenly distributed effective precipitation)

Figure 3 : Validation de l'estimation maillée de mQA, avec des classes de valeur par type de climat (du 1, le plus aride, au 6, le plus humide)

Table 2 : Three estimates of BFI using different hydrograph separation methods for five catchments in

Table 2 : Three estimates of BFI using different hydrograph separation methods for five catchments in South Africa (FID = FRIEND Station Number)

Table 2 : Trois estimations du BFI (index de l'écoulement de bassin) exploitant trois méthodes différentes de séparation des écoulements, pour 5 bassins en Afrique Australe (FID = n° de station dans la base FRIEND)

Station	FID	BFI, filter (Rank)	BFI, rational (Rank)	BFI, turning points (Rank)	Range amongst different BFI methods
B6H003	27524003	0.40 (1)	0.34 (1)	0.52 (2)	0.18
B7H004	27521004	0.36 (2)	0.30 (2)	0.55 (1)	0.25
G1H012	27711412	0.30 (3)	0.16 (3)	0.40 (3)	0.24
H1H007	27711312	0.21 (4)	0.12 (4)	0.22 (4=)	0.10
G2H012	27694907	0.20 (5)	0.07 (5)	0.22 (4=)	0.15

While there is considerable scope for a much broader regional investigation of this kind, and an evaluation of the relative merits, this preliminary comparison demonstrates that different methods of hydrograph separation yield substantially different estimates of BFI when applied to the a common data series. It also demonstrates that the rank of the five catchments remains largely independent of the base flow separation procedure. These interim conclusions introduce significant restrictions for the use of these algorithms for calculating absolute base flow contribution (that is Base Flow in flow or unit runoff terms), as may be implemented for recharge estimation. In the example of G2H012, absolute estimates of base flow contributions would be three times higher by the filter and turning point methods compared to the rational method. This establishes the necessity for the consistent use of a single method within regional studies - by implication, previously calculated BFI values from different countries using different hydrograph separation methods can not be rigorously compared. However, ranking suggests that higher BFI catchments are identified as higher BFI catchments irrespective of the method used. There is therefore merit in each of the individual indices in representing the relative importance of base flow contributions in a consistent manner. The distinction between the different methods is attributed to their relative capability to distinguish different types of base flow, in the spectrum between sustained groundwater contributions and event-based recessions - although none can be interpreted in such physically-realistic terms.

Adopting the turning-point method as a regionally consistent method - for pragmatic reasons that each country has software for its calculation and its use in other FRIEND projects worldwide, while recognising some criticism of the method in semi-arid regions - the Southern African FRIEND project has sought to explain the spatial variability of BFI in relation to climatic regimes and regional hydrogeological classifications. This investigation has adopted a strategy based on three hypotheses; first, that baseflow is dependent on effective recharge, as determined by the climatic regime; second, that aquifer properties determine the capacity of a catchment to accept recharge and to redistribute aquifer /streamflow contribution in time; and third, baseflow as a relative contribution to streamflow can be influenced by 'loss' processes, such as transmission losses into channels and evaporation losses by wetlands and floodplains. Overall, preliminary results are promising in suggesting that baseflow can be explained by adopting this strategy, but there are subsequent and significant analyses which are required.

Flow duration curves

Standardised one-day duration period-of record flow duration curves for a representative sample of 240

of the 676 FRIEND gauged sites on rivers across Southern Africa are presented in Figure 4. Standardisation of curves by MAR removes the scale effects of basin area and runoff volumes, and enables both comparison of flow variability amongst the regional data set, and isolation of other explanatory factors, principally the hydrogeological controls upon flow regimes. The standardised curves display the wide range in flow regime variability that is experienced in rivers across the Southern African region, being characterised by two key features; the range of slope which distinguishes between stable (flat) and highly variable (steep) regimes, and the variation in the frequency of zero flows, reflecting the intermittency of flow in a large number of water courses.

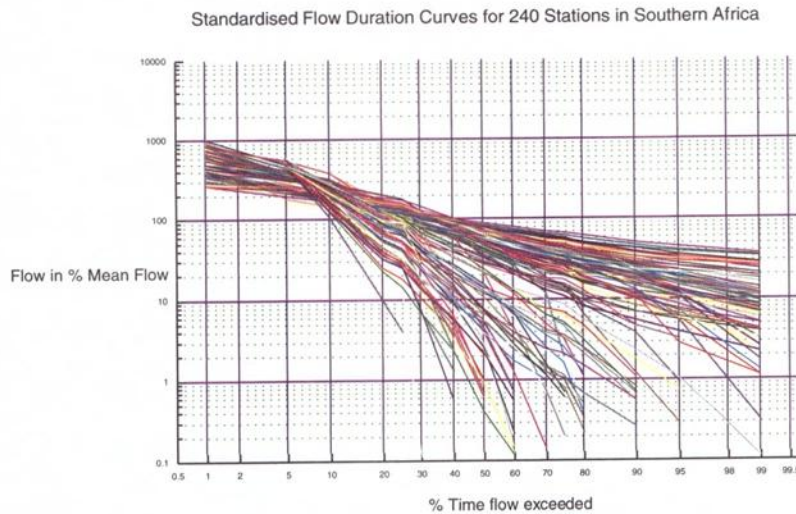

Figure 4 : Range of standardised flow duration curves amongst 240 gauged rivers in Southern Africa
Figure 4 : Courbes de débits journaliers classés normés au module ($DCXd/mQA$), en valeurs brutes pour 240 stations en Afrique Australe

Within the parts of the world where regional low flow studies have evolved - historically in western Europe and the USA - the Q95 percentile (that flow exceeded or equalled 95% of the time) has been adopted as a key flow duration index. However, in many Southern African rivers, Q95 is zero in many rivers, and the statistic has less merit as a distinguishing variable. Consequently, higher flow percentiles are used and in Southern Africa the Q70 statistic has been adopted for current purposes.

The slope of the flow duration curve can be indexed by the ratio of one percentile to another; in this case, the ratio Q10/Q70 was used. In a stepwise regression on perennial catchments employing Q10/Q70 as the dependent variable, and the full set of catchment characteristics as independent variables, it was identified that Q70 (as a % of mean flow) was the single determinant of the slope of the curves. In essence, this confirms an attribute identified for flow duration curves elsewhere in the world - that the slope of the curve is closely associated with a standardised low flow percentile; that is, curves with a low value of standardised Q70 are steeper than curves with a higher value of Q70. This attribute facilitates the construction of pooled curves based on sampling by a standardised low flow percentile, being Q70 in this case. Inspection of a number of curves indicated that they did not plot exactly as straight lines using a log normal transformation - a common assumption for flow duration curves - and the pooled curve method is therefore preferred to a two-parameter description. In the development of a pooled curve, individual curves were constructed for all flow series with Q70 within a specified range, and a pooled curve derived based on mean standardised flow values for key percentiles. This exercise is repeated for all Q70 groups. Interpolation in log space between the pooled curves contributed to the construction of a family of twenty flow duration 'type curves' (Figure 5). Based on an assumed knowledge of Q70, such type curves characterise the flow duration response of perennial rivers in Southern Africa. Further research is required on flow duration behaviour, and curve prediction, in ephemeral rivers of the region.

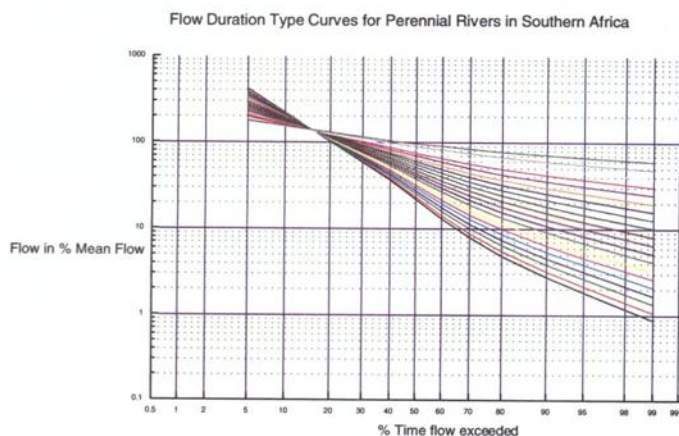

Figure 5 : Flow duration type curves for perennial rivers in Southern Africa

Figure 5 : Courbes de débits journaliers classés normés au module ($DCXd/mQA$, lissés/modélisés, pour les rivières pérennes de l'Afrique Australe

It is an interesting feature of the Southern African region that the sample of standardised curves for the Republic of South Africa within the FRIEND data set displays broadly the same range of curves as that displayed by the other ten countries together - that is, the variability of standardised flow regimes for Southern Africa are essentially encapsulated by the standardised flow regimes of South Africa. This has the important implication that other low flow estimation procedures which have been previously developed in South Africa, such as synthetic drought sequences (WRC, 1994) can be of wider geographical value without exceeding the hydrological domains of regime applicability.

Drought severity assessment

The Southern African region has experienced a series of droughts in recent years which, amongst a set of devastating environmental and socio-economic impacts, have posed a severe threat to water supply security. Impact mitigation measures can be implemented in advance of drought events, through the incorporation of 'drought-proofing' measures in vulnerable regions, which protect communities against future droughts. In the event of a drought, further emergency response measures can be implemented but such mechanisms rely upon an assessment of drought severity, particularly in the context of historic records. There is a tendency for drought severity assessments to be implemented after a drought has finished, and analyses are undertaken retrospectively. This is particularly the case in context of African hydrological droughts because of the time-delay in processing hydrological data from observed levels to flows. Consequently it is difficult to assess hydrological drought severity with anything other than hindsight, thus limiting effective policy response mechanisms during a drought event. The increase in telemetry based data transmission, particularly as promoted by the new WHYCOS (World Hydrological Cycle Observation System) programme of WMO, creates new opportunities for drought severity assessment in close to real-time. The regional nature of the WHYCOS programme further creates the opportunity for severity assessments which are regional in nature.

A preliminary example of the type of output that can be generated is presented in Figure 6, within the Zambezi basin. Flow duration curves were constructed for 70 gauging stations based on historic flow data. A single day was randomly selected - July 1st, 1983 - and by comparing, at each gauging station, the flow on that day with the flow duration curve, a flow percentile was calculated. Figure 6 represents the spatial variability of the flow percentile, and highlights the considerable variability that can exist within a single river basin on any single day.

In studies of river flow drought, one method which hydrologists commonly adopt is that of low flow frequency. An analysis of annual minimum flows in historic time series enables an assessment of the return period of a particular drought event. The principles are analogous to flood frequency analysis, in

that the procedure commonly involves the fitting of a selected extreme value distribution to sampled annual minima, where there are many different distributions and several different fitting procedures. Although analogous to flood frequency, low flow frequency analysis has not yet received the same level of investigation and application, and these methods can be thought of as being in their infancy in Southern African, where there are a set of specific problems posed by flow regimes in the region. It is a clear and obvious direction to reproduce the type of graphical display portrayed by Figure 6 using low flow frequency rather than flow duration techniques. To do so raises key scientific issues, such as handling non-annual minimum events, low flow frequency analysis with zero flows, seasonal analyses, appropriate distribution and estimation methods, spatial statistics, as well as the issue of visualisation. This area of work is foreseen to be a major element of the next phase of Southern African FRIEND, moving towards the capability to assess, in close to real-time using SADC-HYCOS data, the severity of a current or evolving hydrological drought at a regional Southern African scale.

Discussion

The Southern African FRIEND project has assembled an international data base of time series of daily flow data for nearly 700 flow records, with associated GIS-based climatic and thematic coverages relevant to river flow regimes. These data sources provide the basis for regional analyses of water resources and drought. This contribution to the 3rd General FRIEND report presents a sample of activities undertaken within the programme, and has focused on mean annual runoff, base flow contributions flow duration curves and regional drought assessment. The FRIEND programme represents the first attempt to study these measures of the flow regime at the regional scale of Southern Africa, and some significant advances have been made. However, this FRIEND group recognises that only a start has been made on this topic, and that there is much scope for future activities in the region to advance this research area. Of course, low flow and drought activities in Southern Africa have not been uniquely implemented within FRIEND and there are many examples of national studies and research work which have been undertaken on this topic over many years.

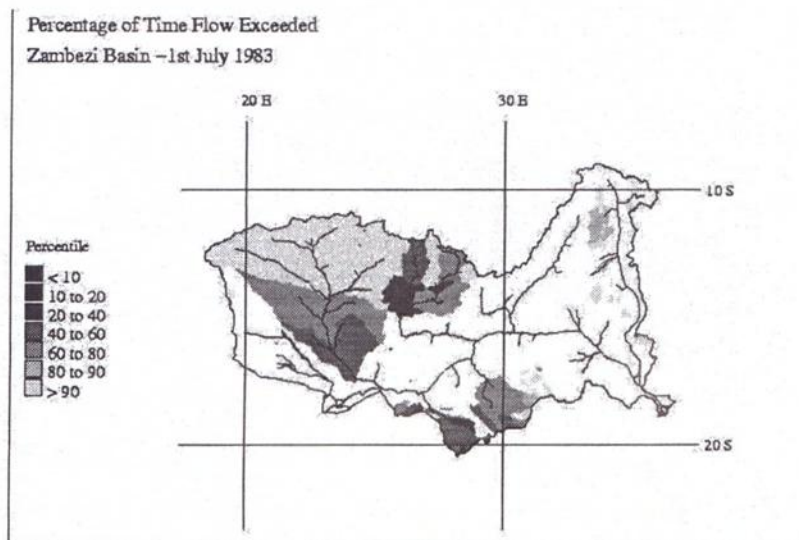

Figure 6 : Distribution of flow duration percentiles in the Zambezi basin on 1st July 1983

Figure 6 : Distribution des quantiles de débits classés (DCXd) dans le bassin du Zambèze, le 1/7/83

Long term effects of rain shortage : the ill rivers of Western and Central Africa

Effets durables du déficit des précipitations : les rivières malades d'Afrique de l'Ouest et du Centre

J.C. Olivry

Introduction

The extent of the current drought phenomenon in Sudano-Sahelian regions no longer needs to be proven. The study of rainfall deficits in intertropical Africa shows a regional climatic degradation which has been going on for about twenty five years. These deficits have important impacts on the flow of river basins, and are usually amplified. Such deficits also concern the humid areas of Western and Central Africa (Figure 1).

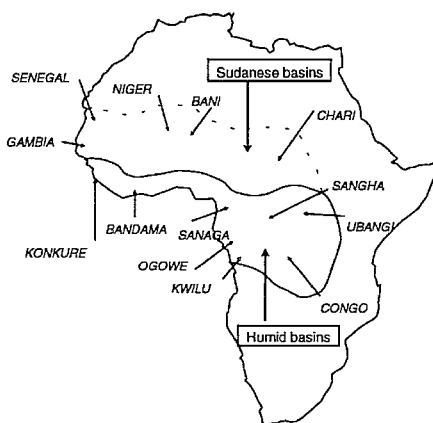

Figure 1 : Location of the river basins studied in Western and Central Africa.

Figure 1 : Situation des bassins versants étudiés en Afrique de l'Ouest et du Centre

In this research area, the Senegal, Niger and Congo rivers present the longest chronological series of flow data in Western and Central Africa. Various studies have shown that the current rainfall deficit phenomenon greatly differed, in intensity and duration, from other 20th century deficit situations (Olivry, 1983, Sircoulon and Olivry, 1986, Sircoulon, 1987, 1989, 1990; Hare-Kenneth, 1985). Despite very great fluctuations which could indicate pseudocyclic variations, reconstruction undertaken in the second half of the 19th century identify a general downward trend during the past 150 years (Olivry and Chastanet, 1986). Moreover, some authors have identified a statistical break in the rainfall conditions in 1970 (Hubert *et al.*, 1989; Paturel *et al.*, 1996).

Without anticipating a continuation in this trend, or, on the contrary, a return to a humid period, the current drought will have long-term consequences for some hydrological parameters. After a relative improvement of rainfall conditions, observed in 1985 and 1986 and even more recently, as shown by the evolution of the Lamb index (Lamb, 1985), a memory effect of the drought may be observed in the flow of large river basins. (Figure 2).

African drought and rainfall deficits observed in the past 25 years have important repercussions on the flow regime of rivers and especially on the annual runoff and the magnitude of annual floods. Flood hydrographs of large river basins have been greatly reduced in volume and duration; maximum values

are much smaller. This phenomenon has intensified during the last ten years while, paradoxically, rainfall deficit has diminished. For example, the upper Niger river, with the Bani river, (surface area of 250,000 km²) shows an annual runoff deficit of 20% during the 1970's and of 46% during the 1980's and an annual rainfall deficit respectively of 15 and 20% (Bricquet *et al.*, 1996). In the regional context of Western and Central Africa, the regional runoff deficit varies from -7% to -16% for the decades 1970 and 1980 in the humid areas, and from -13% to -27% in the dry areas (deviations calculated in relation to the 1951-1990 mean values) (Mahéet *et al.*, 1991, 1995; Olivry *et al.*, 1993).

The long term effects of rain shortage are even more marked for the low flow regimes. Different studies have shown that, in addition to the immediate effects of the drought, a large reduction of the groundwater storage can explain the persistent fall of the hydrological resource.

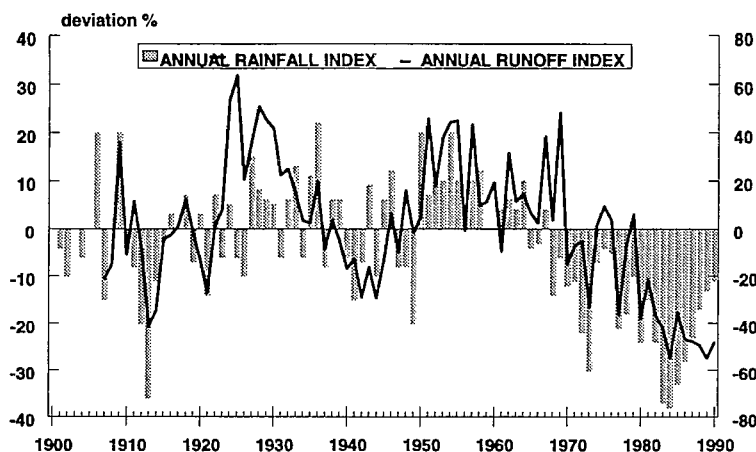

Figure 2 : *Interannual variations of rainfall and discharge indices in the West Sudano-Sahelian Africa*
Figure 2 : *Variations interannuelles des indices de précipitation et de débit dans l'Ouest de l'Afrique soudano-sahélienne.*

Reductions in low flows

The memory effect of the current deficit period is particularly clear. In the case of the recession-depletion period and low flows, an unusual repetition of exceptionally dry low flows can be observed an abrupt change in the depletion regime, unprecedented in hydrological time series. It also may be observed that a return to more favourable climatic conditions does not involve an immediate return to the earlier hydrosystem.

Figure 3 shows two representative curves of the variability of the low flows (absolute minimum daily discharge) between 1950 and 1990 for a Sudano-Sahelian basin (the Bani river) and for a tropico-equatorial basin (the Sangha river, tributary of the Congo river). It is clear that dry Africa is more affected by drought and rainfall deficits than humid Africa, but during the last decade the low flows of the Sangha river are less than 50% of the low flows observed before 1970 (Laraque *et al.*, 1996). Equivalent low flow reductions were also observed on the flows of the Ubangi, Congo/Zaire, Ogowe, Sanaga, Kwilu, Bandama and Konkure rivers in the humid areas during the last decade (Olivry *et al.*, 1993). In dry Africa the reduction of low flows is even larger still and it has been observed during the last two decades.

Another example is given by statistical studies of the low flows of the Chari and Logone rivers in Chad. Before the drought, the median minimum discharge of the Chari river was estimated to be 126 m³s⁻¹ and the dry decennial value to be 88 m³s⁻¹ in N'Djamena. During the 1980's, the minimum discharges fell between 20 and 25 m³s⁻¹. In the same context for the Logone river, a tributary of the

Chari river, the median and dry decennial values were estimated respectively to be $40 \text{ m}^3 \text{ s}^{-1}$ and $24 \text{ m}^3 \text{ s}^{-1}$, with many of minimum discharges in the recent period being under $10 \text{ m}^3 \text{ s}^{-1}$.

All these data indicate a real change in the low flow regimes, with the smallest discharges observed during the century and also longer dry seasons.

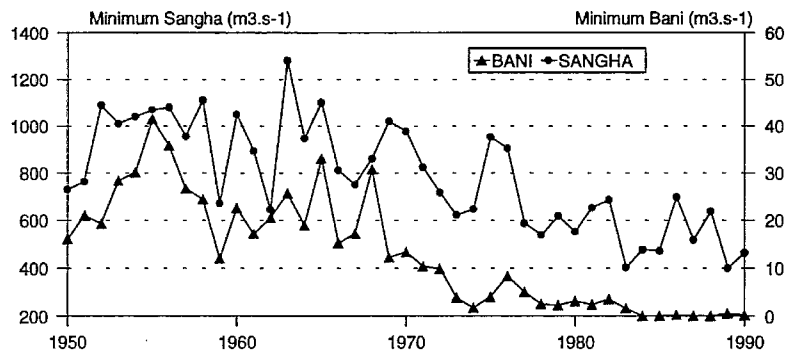

Figure 3 : Variability of the annual minima in Sudanese (Bani) and Equatorial (Sangha) regions (after Mahé, 1991).

Figure 3 : Variabilité des minimums annuels dans les régions soudanaises (Bani) et équatoriales (Sangha) (d'après Mahé, 1991).

The low flow disease: an actual hyperdepletion

After the annual flood and the recession, which occurs as soon as the rainy season ends, there is a classical pattern of flow reduction in the rivers in this region. This corresponds to the drainage of the basin aquifers, also called depletion. This depletion is linked to an exponential law: $Q_t = Q_0 e^{-a(t-t_0)}$ with the flow Q_0 on a t_0 day, the flow Q_t on a t_t day, and a , a coefficient expressed in days^{-1} , according to the physical and geometrical characteristics of the aquifers.

The studies show a significant degradation of the rate of depletion. This phenomenon, resulting from a deterioration of aquifers, was first noted on the Senegal river in 1983 (Olivry, 1983; Olivry, 1987). Since then, it has been observed repeatedly in relation to all the streams in the Sudano-Sahelian region. On a regional scale, it can be considered as a likely model of the progressive draining of streams.

In the Senegal river (218,000 km^2 at Bakel), the depletion coefficient has been relatively stable for over seventy years during humid as well as dry periods. The extreme values are 0.022 day^{-1} and 0.016 day^{-1} , the average being 0.0186 day^{-1} and the coefficient of variation being only 0.075. With the current drought, the alteration in the pattern only becomes significant after 1975. The depletion coefficient rapidly rises, to reach values such as 0.04 day^{-1} around 1985, prior to the flow regulation introduced by the Manantali dam. During the single period of the depletion observation (4 months from October to January), the water resource deficit represents an average of $100 \text{ m}^3 \text{ s}^{-1}$ (1 km^3). The Niger river (120,000 km^2 at Koulikoro with data since 1907) shows a depletion prior to 1975 which to represent an average coefficient of 0.026 day^{-1} during a humid period of 20 years, with an average coefficient of 0.023 day^{-1} . The current period shows an average coefficient over the first 8 years as being around 0.028 day^{-1} and then an abrupt increase to values as high as 0.040 day^{-1} in the beginning of the 1990s. The Bani river (102,000 km^2 at Douna), tributary of the Niger river shows a similar pattern (Bamba *et al.*, 1995, 1996) (Figure 4).

Further to the east, the Chari (600,000 km^2), a main tributary of Chad Lake, and measured at N'Djamena showed a relatively stable depletion from 1933 to 1971 ($a = 0.019 \text{ day}^{-1}$). Since then, the depletion coefficient has increased up to 0.028 day^{-1} . It is easy to give many examples in the Sudano-Sahelian region - the phenomenon is also prevalent in humid, tropical areas, although it is less marked. Thus in the case of the Ubangui river at Bangui (500,000 km^2), the average coefficient from 1935 to

1975 was 0.021 day^{-1} , and it has been equal to 0.025 day^{-1} during the last fifteen years. The increase of the depletion coefficient of the Sangha river is lower, but in equatorial regions it is often difficult to observe the depletion periods during a short dry season (Figure 5).

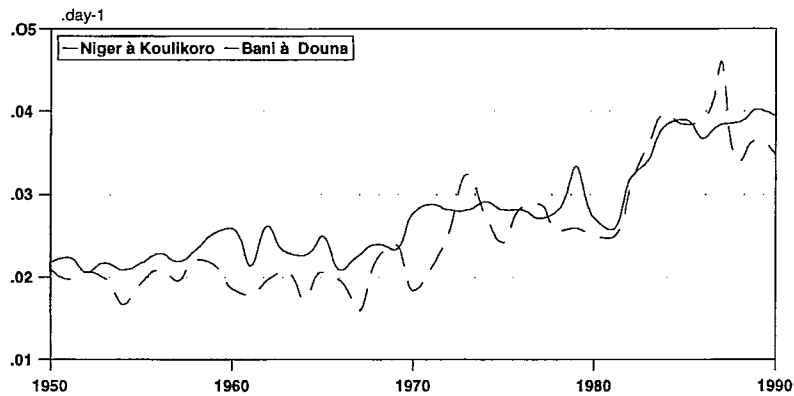

Figure 4 : Variability of the depletion coefficients of the Niger and Bani rivers, since 1950. (after Bamba et al., 1995)

Figure 4 : Variabilité des coefficients de tarissement des rivières Niger et Bani, depuis 1950 (d'après Bamba et al., 1995)

The similarity of the depletion coefficient in the case of different rivers and also of streams which were observed in the flow time series before the current period must be underlined. The a values of 0.02 day^{-1} are characteristic of a low water supply deriving from small hillslope aquifers. These aquifers are typical of intertropical Africa geomorphology, where there is no significant groundwater. A good relationship exists between the coefficients of variation of recession and of drainage (Olivry, 1976). According to Darcy's law, the deviations from the norm would mainly correspond to variations in the aquifer width. The hydrogeological data show a drop of 10 metres and more of the water table above hillslope aquifers in Senegal, Mali and Burkina Faso during the 1980s. Consequently, there is nothing surprising in the fact that the decrease of these small aquifers results in a comparable hyperdepletion in the basins of various areas affected by the same climatic hazards.

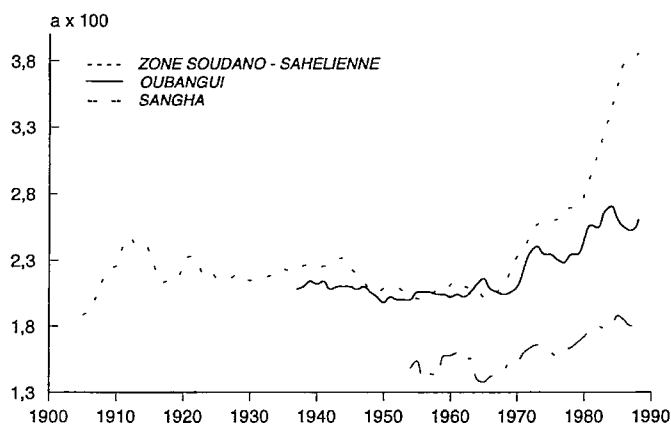

Figure 5 : Variations of the mean value of the depletion coefficients of the Sudanese rivers from the Senegal river to the Chari river and of the depletion coefficients of the Ubangi and Sangha rivers in humid Central Africa (after Olivry et al., 1993).

Figure 5 : Variations de la valeur moyenne des coefficients de tarissement des rivières soudanaises depuis le fleuve Sénégal jusqu'à la rivière Chari, et des coefficients de tarissement des rivières Oubangui et Sangha de l'Afrique Centrale humide (d'après Olivry et al, 1993).

Future prospects

A return to better sustained discharges during the dry season first requires aquifer recharge. This cannot happen immediately, as shown by the low effect on depletion coefficients of the most recent improved rainfall. There is no exact convergence between the variations of Lamb's rainfall index and the depletion coefficient. Through the aquifers, responses to low water recharge are slower; they require a response time of several years and only become effective with the accumulation of similar climatic variations.

A specific stream drought, which could be referred to as a "phreatic drought", is to be added to the climatic drought with a multi-year gap. The hydrogeological laws are such that, under good rainfall conditions, a restoration of the low flow regime should last as long as it took to bring it to its current degradation.

The climatic evolution in the next few decades obviously remains the mainspring of eventual evolutions (Sircoulon, 1989,1990). Various scenarios may be considered :

- *Drought continuation or aggravation:* the processes pointed out are increasing; quite soon the rivers will no longer be sustained during the dry season because of an exhaustion of resources. This pattern leads to Sahelian and subdesertic stream regime and, in the long run, leads to the fossil hydrographic network of the Sahara.
- *Occurrence of a long humid period, comparable in duration to the current deficit period:* a progressive return to the previous low flows is foreseeable, with a recovered abundance of water resources in these regions after ten or fifteen years in the current context.
- *A momentary recovery to surplus rainfall (less than ten consecutive years):* a slight improvement will be observed, but the return to previous low flows will be broken off by new dry periods. The further evolution of the stream regime will depend on the duration of these dry periods. Alternating with humid periods, this scenario leads to a depletion coefficient stabilising at a higher level than the one observed during the decades before 1975, and thereby it leads to a deterioration of sustained dry season resources.

Conclusions

Beyond the consequences of the most pessimistic hypothesis, it is to be emphasized that the event of a median climatic situation leads to sustain the hydrological regime degradation of the rivers of the region. Even in the most optimistic scenario, the effects of the current drought will still be felt for many years.

The groundwater supply deficit in rivers, detected in the dry season, and which has been discussed, is also evident during the flood period. This explains the low annual flows and the poor flood maxima observed despite some rainfall recovery. A frequency study of flood maxima shows a clear break in data series, and emphasizes the danger of flood estimations which are based upon recent years only. The "memory effect" of the drought indicates the important contribution of base flow to the flood hydrographs of large rivers.

The gap between climatic and « phreatic drought » should, in the case of lasting deficits, lead to a careful use of hydrological parameters as indices of climatic variations.

Finally, the current situation of dry season flows highlights the importance of water resource development strategy and an irrigated system of farming; these two conditions can guarantee a proper food crop, deeply affected by the West Africa climatology.

Acknowledgements

The author would like to thank the hydrological and meteorological services of Western and Central Africa and the FRIEND AOC which permitted this work with the provision of recent data.

Drought in South-Eastern Europe

La sècheresse dans la partie Sud Est de l'Europe

Sn. Dakova

Introduction

South-eastern Europe is one of the regions worst affected by drought, due to climatic and anthropogenic influences. This paper discusses the recent drought in the region in terms of the underpinning climatic and anthropogenic characteristics of the region, and assesses the regional occurrence through an analysis of low flows.

Climatic behaviour and drought

The Mediterranean countries are located within the Atlantic-Mediterranean climatic zone, and experience the weather associated with Mediterranean cyclones, approximately 12 and 15 per year. During the most recent decade about 3 - 4 cyclones per year have occurred. Being relatively weak, their east to west movement has been inhibited affecting the regular distribution of rainfall over the region. The locations where they have originated (in Greece, Italy and Southern France) have experienced intensive convective rainfall over small areas - Torino recorded 440 mm within 12 hours on November 5, 1994. However, at the same time, Macedonia, Bulgaria, Romania and Turkey experienced precipitation at about 40 - 50% of normal.

During the period since 1983 rainfall has generally been below normal, and especially scanty in the last 5 years - although local intensive precipitation contributes to improve the dryness for short durations. Over Bulgaria, annual precipitation amounts has been about 60% of the norm, over Yugoslavia between 40 and 90%. From the end of 1992 until the end of March 1993 rainfall in Italy, Spain and Slovenia amounted to only 10% of the normal, and in Portugal between 6 and 25%. According to preliminary investigations (GCSR, 1995) a movement of the Icelandic low pressure system some 700 - 800 km to the east may be responsible for the dry conditions in South-Eastern Europe. During January 1994, bitterly cold Arctic temperatures penetrated as far south as southern Italy and the Balkans, leading to temperatures as low as -50°C in Russia, -28°C in Romania, and -12°C in Italy. Heavy snow generally over the Central and Eastern Europe during the last decade is linked to warm and dry weather.

Low rainfall has been aggravated by the high temperatures, with summer average temperatures being 2 - 4°C above normal, and frequently equalling or exceeded historic maxima. In the summer of 1994 Vienna experienced the highest temperatures within 220 years of observation; Hungary experienced temperatures exceeding 37°C on more than 20 days, while in the Iberian peninsula the temperature reached 46°C. In addition to unusually high temperatures during the summer months, unusually high temperatures were experienced at other times of the year; in Bulgaria in March and April the maximum was reached and in 1990 in Southern France the average winter temperature average was 3-3 to 5°C higher than normal.

From a global point of view during the last 135 years, the global temperature has increased by 0.5°C. A number of studies seem to be unanimous in their conclusions that in the last 15 years a significant meteorological drought has been experienced in Central and Eastern Europe. It remains unresolved whether this phenomenon represents natural variability of the climate or whether it is associated with climate change.

Human influences on drought

The countries of South-Eastern Europe fall within the dry-subhumid zone and due to the characteristic water shortages in summer, the water supply activities have developed in correspondence with the social and economic activity. After the Second World War the construction of reservoirs (barrages) was especially active, in Bulgaria, Romania, Greece, etc... . This activity has decreased during the last decade. Development has been to the extent that in Bulgaria the total volume of all reservoirs represents nearly 30% of the water resources of the country. Hungary represents an exception in the region, partly because this country falls in the sub-humid zone, but also because the topographic conditions limit the possibility of constructing storage reservoirs.

During the period of the recent meteorological drought, the contribution of human activity to the hydrological drought has two opposite directions with variable severity in the different parts of the river.

Among the anthropogenic influences on the catchment area, the most important concern forests, urbanisation and agriculture. During recent decades, activities related to forestry have intensified the drought phenomenon on account of forest funds decrease and also to the change of the forest structure (Romania, Bulgaria, etc...). The role of urbanisation has been to increase runoff effect from urbanised areas, as well as to change the precipitation regime. The effect of agriculture has been a dual one - on one side the influence is negative due to the modern methods of cultivation and the bigger percentage of hydrophyllic plants in the region, and on the other side the influence is positive through the backwaters coming into the river when the irrigation systems use the regulated reservoirs water.

The effect of the influence of anthropogenic activities on the catchment area is very slow - and up to now the necessary information concerning the quantitative estimation of the mentioned influences does not exist.

Human activities connected directly with the river network can be formed into two groups :

- systems which do not redistribute runoff in time, such as water intakes, returned water, backwatering systems, etc... . The water intakes decrease runoff and aggravate drought conditions. The backwatering systems including sewerages and returning water from irrigation increase the runoff i.e. mitigate the drought.

- systems, such as reservoirs, which in principal mitigate the drought by accumulating river waters during the rainfall periods and redistributing them in time and in space during the dry periods in the annual or multiannual cycle. When the duration of drought prolongates like last one, the multi-yearly regulating potential of the reservoirs is exhausted, and this leads to water crisis (as example, these in Bulgaria 1994-1995, Romania 1993-1994, etc...).

Low Flows and Drought

These two terms are closely associated but are not equivalent. Low flows occur over periods of a few weeks, months or seasons (summer, or summer and winter) throughout the year or as over-year events across two consecutive years. Drought is a more common term, because it has different aspects of manifestation (meteorological and agrometeorological, etc.). Drought is connected with the resource implications of water availability and in this sense represents a characteristic not only for one year, but for a period or sequence of dry years. Droughts include low flow events but a low flow event does not necessarily constitute a drought.

A regional drought characterisation methodology is based upon the basic concept of point drought-affected areas, with mainly analytical, probability and statistical methods being used. Turkey and Yugoslavia apply the Yvjevich method, using as a threshold (transaction) level based on a constant

water demand (Bulu, 1984 ; Radion, 1994). A threshold of the multiannual mean discharge is used in Romania and in Bulgaria. Independently of the differences in derivation, the countries of the Balkan peninsula have registered that 1935, 1944-1946, 1950-1960, 1962-1963, 1982 and during the last 13 years represent drought conditions. In Romania the drought began in 1982 and after 1990 it was provoked in Bulgaria, especially in 1994.

By using cumulative probabilities of the annual flow of the 7 rivers on the European part of Turkey the probability of manifestation of the longest dry period (less than 3, 6 and 9 years) was calculated. The probabilities have the large limits depending on the preliminary chosen threshold level. Multiannual mean monthly discharge for periods 1935-1985 and 1935-1995 of Bulgarian rivers was analysed. For the first period, spells with a duration of 1-2 to 5 successive years with the probability of 75%, 90% and 95% are determined using some modification of the nonparametric criterion for number and length of spells below a mean value. Analysing the second serie (1935-1995), the spell of 13 numbers corresponding to the length of the last drought was obtained. The length of random time serie including at least one spell with 13 elements must be 250 years with probability $\leq 5\%$. That sort of serie with water discharge values is not available in South-Eastern European countries. So, now it is impossible to maintain that it is a naturally variation of the time series, or it is effect of some causes (as example climate change).

This analysis corresponds to the conclusions made for the annual discharge. The multiannual average for the period of 1972-1994 corresponds to 90% of reliability, which is determined in 50 years of the preceding period (Mandadjiev, 1995).

Using water deficit as a measure of drought severity, analysis of the series of annual discharge show certain regionalisation by territory, as well by altitude. The most affected catchments have been those with a typical expressed Mediterranean climate, where in the last decade the discharge has been 40% lower than those in 1935-1985. The deficit is smaller, close to 25%, in the mountains compared with lowland zones.

Although different time periods have been used in different countries, similar conclusions can be drawn;

- after 1982, drought occurrence was observed in all the countries of the region. This phenomenon occurred with different intensity in different years.
- studying the phenomenon using similar elements of frequency analysis, it can be considered that the phenomenon is well evaluated in the countries of the region.

When the methods and time-units will be unified, the results will be considerably more categorical, Unifying methods between countries will facilitate future regionalisation. An example of a unifying element is the French QDF model, which could be equally well applied in Algeria and in Romania.

Conclusions

In contrast with rainfall data, the length of river discharge observations vary for the different countries, and do not exceed 40 years. For many countries, a part of this period is encumbered by difficulties with transformed rivers, because of the lack of information about the anthropogenic influences within the territories of the different countries.

13 years drought was observed in all countries of the region. Analyses have shown that the magnitude of this drought does not have a historical precedent within the region. Being reminded that in the contemporary hydrology practice the methods and analysis are based on the assumption that meteorological conditions recorded in the past will be repeated put a question how we will work in the future drafting hydrotechnical projects. A lack of categorically explication of the character of the most

recent drought raise two alternative possibilities:

1 - to accept that the last drought is a natural variation of the hydrological time series. In this case, we will use all data up to now.

2 - to admitt that the last drought is affected by some causes (as example climate changes). In this case, the hydrological time series are statistically inhomogeneous. Having in mind the last meteorological assuming for global changes and especially warming of the weather in the South-Eastern European regions, it is reasonable to work with the records of water discharges obtained after 1982.

Acknowledgement

The low flow project of AMHY began its activities in 1993-1994. Attention was concentrated on methods for determining parameters at different states of river discharge, for example at zero discharge or using the QdF model. The meteorological drought during the last decade has led to studies of its consequences on the state of the rivers in the region. Only the results of this short time of work are discussed.

Statistical analysis of low flows with zero discharges

Analyse statistique des étiages avec débits nuls

A. Bulu

Introduction

In semi-arid and arid regions, hydrologists encounter data series which contain zero values. The same situation also arises in cold regions where the rivers are frozen during the winter season. Zero flow values pose problems which have to be taken into consideration in frequency analysis methods. One proposed solution is to add a small amount to all of the values in the set (for example, 1% of the mean magnitude) and then fit a continuous distribution. Kilmartin and Peterson (1972) applied this method in developing rainfall-runoff regression with logarithmic transformations and zeros in the data for the San Lorenzo River, at Big Trees, in California. A second method essentially ignores the zero values, analyzes the non-zero values, and adjusts the results to the full period of record. Clearly, the results are biased in this case. A third and theoretically more sound method is to use the theorem of total probability:

Theorem of total probability

The theorem of total probability is:

$$P(X \geq x) = P(X \geq x | X = 0)P(X = 0) + P(X \geq x | X \neq 0)P(X \neq 0) \quad (1)$$

Since $P(X \geq x | X=0)$ is zero, the relationship reduces to:

$$P(X \geq x) = P(X \neq 0)P(X \geq x | X \neq 0) \quad (2)$$

In this relationship $P(X \neq 0)$ is estimated by the fraction of non-zero values, k , and $P(X \geq 0 | X \neq 0)$ is estimated by a standard analysis of the non-zero values, with the sample size taken to be equal to the number of non-zero values. It can be written as a function of the cumulative probability distribution

$$1 - F(x) = k[1 - F^*(x)] \quad (3)$$

or :

$$F(x) = 1 - k + kF^*(x) \quad (4)$$

where $F(x)$ is the cumulative probability distribution of all $X[P(X \leq x | X \geq 0)]$, k is the probability that X is not zero, and $F^*(x)$ is the cumulative probability distribution of the non-zero values of $X[P(X \leq x | X \neq 0)]$. This is a mixed distribution which has a finite probability that $X=0$ and a continuous distribution of probability for $X>0$. Jennings and Benson (1969) have demonstrated the applicability of this approach to analyzing flood flow frequencies with zeros present. Bulu *et al.* (1995) have also applied this method for the frequency analysis of low flows.

Equation (4) can be used to estimate the magnitude of an event with return period T by solving first for $F^*(x)$ and then using the inverse transformation of $F^*(x)$ to get the value of X . This merely depends on

the probability distribution function applied to the non-zero flow values

$$F^*(x) = \frac{F(x) - 1 + k}{k} \quad (5)$$

since the return period of the low flow can be estimated by:

$$T = \frac{1}{F(x)} \quad (6)$$

Equation (5) takes the form of:

$$F^*(x) = \frac{\frac{1}{T} - 1 + k}{k} \quad (7)$$

The applicability of Equation (7) depends upon getting positive values of probabilities, $F^*(x)$. Therefore, the application of total probability theorem to low flows depends on the relationship between T and k . For the commonly used return periods, the fractions of non-zero values, k , that would be greater are given in Table 1.

Table 1 : k values depending on return period (T)

Table 1 : valeurs de k en fonction de la période moyenne de retour T

T (years)	2	5	10	20	50	100
$k \geq$	0.50	0.80	0.90	0.95	0.98	0.99

For different return periods, k fractions should be:

$$k \geq \frac{T-1}{T} \quad (8)$$

for the application of this theorem. Actually, if we obtain negative $F^*(x)$ values by Equation (7), it means that for that return period T and fraction k , the probability of seeing that flow is zero for the river under consideration. Since the calculation of $F^*(x)$ by Equation (7) is distribution free, the values of $F^*(x)$ can either be calculated from Equation (7) or taken from Figure 1 depending on T and k .

Example application in Turkey

Twenty-three years of 7-day low flow data are available of Hayrabolu River, in the Thrace Region of Turkey. 5 of the values are zero and the remaining 18 values have a mean of $0.11 \text{ m}^3/\text{sec}$, a standard deviation of $0.08 \text{ m}^3/\text{sec}$, and are distributed as 2-parameter Weibull distribution with parameters $\alpha=1.273$, $\beta=0.120$. Examples given are for the following applications:

- to estimate the probability of a low flow less than $0.05 \text{ m}^3/\text{sec}$
- to estimate the magnitude of the 4-year dry low flow
- to estimate the return period of zero flow.

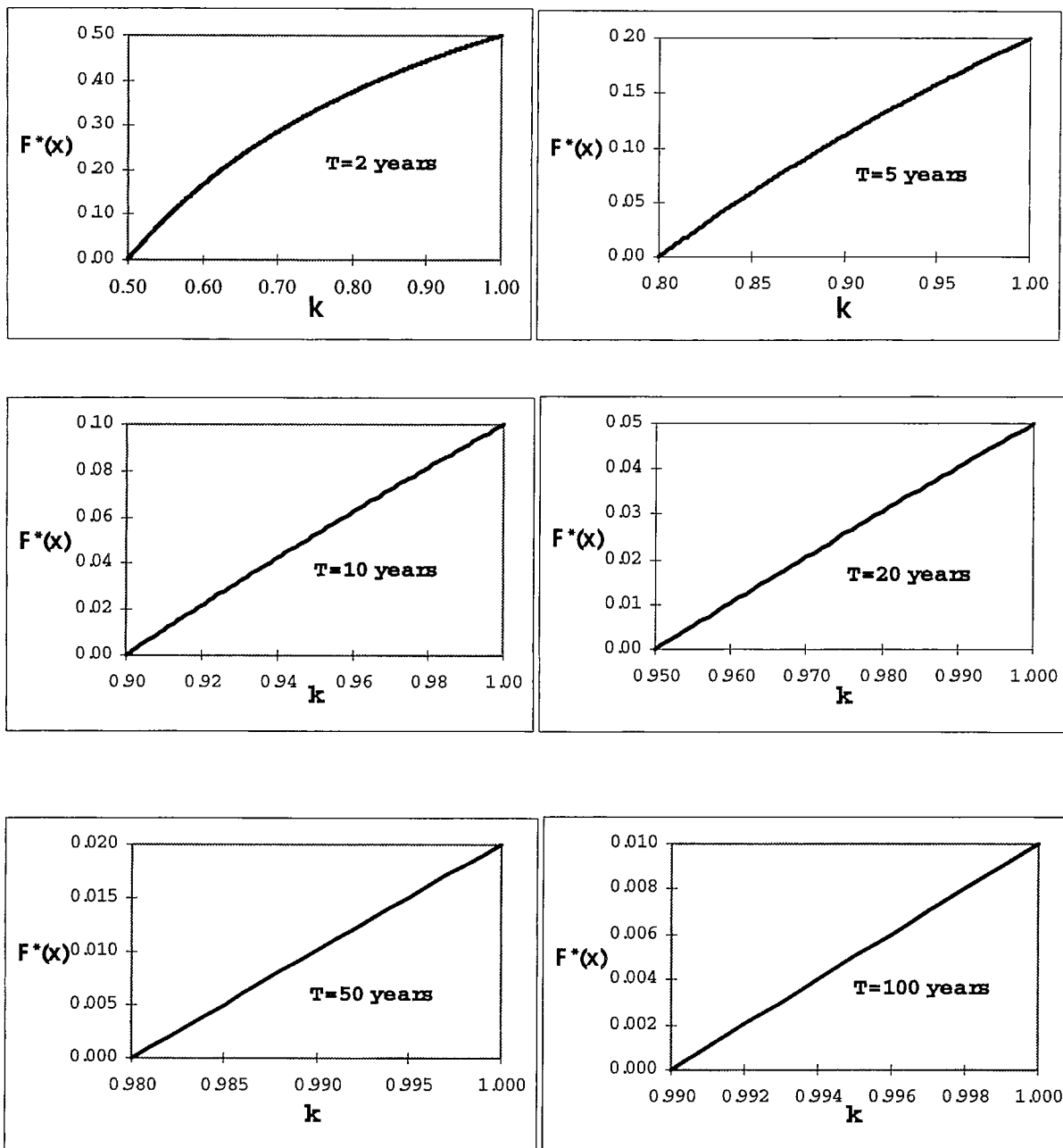

Figure 1 : $F^*(x)$ and k relation for different T return periods

Figure 1 : Relations entre $F^*(x)$ et k pour différentes périodes moyennes de retour T

a) to estimate the probability of a low flow less than $0.05 \text{ m}^3 \text{ s}^{-1}$:

To solve :

$$P(X \leq 0.05) = F(0.05)$$

by applying Equation (4) :

$$F(0.05) = 1 - k + kF^*(0.05)$$

so :

$$k = \frac{18}{23} = 0.783$$

The cumulative frequency function for 2-parameter Weibull law is $F^*(x) = 1 - \exp\left[-\left(\frac{x}{\beta}\right)^\alpha\right]$

and introducing the distribution parameters gives: $F(x) = 1 - \exp\left[-\left(\frac{0.05}{0.12}\right)^{1.273}\right] = 0.28$

Hence : $F(0.05) = 1 - 0.783 + 0.783 \times 0.28 = 0.44$

The probability of a 7-day low flow in any year less than 0.05 m³/sec is 0.44. The conditional probability of a 7-day low flow less than 0.05 m³/sec given that the low flow is not zero is 0.56.

b) to estimate the magnitude of a 4 year dry return period low flow:

Using Equation (8): $k = 0.783 > \frac{4-1}{4} = 0.75$

By using Equation (7), $F^*(x)$ is : $F^*(x) = \frac{\frac{1}{T} - 1 + k}{k} = \frac{\frac{1}{4} - 1 + 0.783}{0.783} = 0.042$

The value of X corresponding to $F^*(x)=0.042$ can be obtained from the 2-parameter Weibull distribution (Bulu *et al.*, 1995) :

$$X = \beta \left[-\ln(1 - F^*(x)) \right]^{1/\alpha}$$

$$X = 0.12 \left[-\ln(1 - 0.042) \right]^{1/1.273} = 0.01 \text{ m}^3/\text{sec}$$

c) to estimate the return period of zero flows:

Using Equation (4): $F(0) = 1 - 0.783 + 0.783 \times F^*(0)$, with : $F(0) = 0.217$

$$T = \frac{1}{0.217} = 4.6 \text{ years}$$

This value is equal to the fraction of zero values for the sample.

Acknowledgements

The author would like to thank his assistants Hafzullah Aksoy and Sevet Cokgor for the preparation of this manuscript.

Symbols

F(.)	: Cumulative probability
F*(.)	: Cumulative probability of non-zero values
k	: Fraction of non-zero values
P(.)	: Probability
T	: Return period
X	: Low flow variable
x	: Low flow value
α	: Scale parameter of Weibull distribution
β	: Location parameter of Weibull distribution

Short discussion of the presented papers

Brève discussion sur les contributions

A. Bullock

The presented papers summarise the activities within four FRIEND groups worldwide concerning the topic of Low flows and Droughts. To place these papers into the broader context of FRIEND activities worldwide, the Northern European FRIEND group, which commenced in 1986, has previously published two reports, which describe preceding low flow analyses. The first report (Gustard *et al.* 1989) included analyses within Chapters on 'Regional low flows studies', 'Research basin studies' and 'Modelling the hydrological response to human activities'. The second report (Gustard, 1993) included analyses within Chapters on 'Low flows' and 'Large scale variations in river flow characteristics'. Each of the other three FRIEND groups reporting in this Chapter - AMHY, Southern Africa, and West and Central Africa (AOC) - are more recent initiatives, which have not previously published a consolidated report of their activities. The topic is also an integral component of three new FRIEND programmes in the Nile Basin, Hindu Kush-Himalayan region and South-East Asia.

Several themes can be identified which run through the different FRIEND groups to varying degrees ;

1. Determination of location, severity and duration of drought : At the present time, the four established FRIEND groups have access to a global database of approximately 7,500 daily river flow series in over 50 countries on two continents. With the evolution of new FRIEND initiatives in South-East Asia, the Hindu Kush-Himalayan region and the Nile Basin, it is not difficult to imagine that by the year 2000, the FRIEND data bases worldwide will approach 10,000 flow series from 100 countries on at least four continents. Accessibility to data of this kind will generate unprecedented opportunities for determining the historic behaviour of droughts and low flows across large areas of the world. Significant advances have already been made in the Northern European and Southern African groups in the application of a regional statistical approach to low flow and drought behaviour, which embrace the full region. These methods seek to understand the factors that influence low flow behaviour, and can lead to predictive methods at ungauged locations. With real prospects of a future worldwide network of real-time river flow gauging stations through the WMO WHYCOS initiative, a new challenge will be posed to hydrologists to be able to determine the location and severity of drought as a drought happens, rather than reviewing historic drought occurrence. This challenge will necessitate links with operational water agencies in alerting decision-makers to drought occurrence, and will likely lead to the growth of the scientific area of flow forecasting during drought for water resource schemes. Two of the presented papers (Gustard and Bullock *et al.*) present some initial developments in this direction, through the regional mapping of drought severity for historic drought events.
2. Development and evolution of statistical methods : Two of the presented papers present developments of statistical methods for drought analysis; the EXDEV program, developed by the Czech Hydrometeorological Institute (described by Gustard *et al.*), and the application of the theorem of total probability for time series containing zero flows, described by Bulu. Additional work, not reported in the presented papers, has involved the recent conversion of the QdF model for flood frequency into an appropriate application for low flow frequency, by the National Institute for Hydrology and Meteorology in Romania (Adler *et al.*, 1997). Clearly, many frequency analyses of low flows and drought are founded on statistical principles and extreme value analysis methods. In 1985, Unesco and WMO collaborated in the production of the 'Hydrological Aspects of Drought'. Given that FRIEND is a contribution to the International Hydrological Programme of Unesco, and that there is a high level of use of

drought analysis techniques in the existing and newly emerging FRIEND groups, it could be a positive move forward to initiate an updated document which sets out the statistical bases for drought and low flow analyses.

3. Trend analyses : An interesting facet in drought analyses is the identification of trends, in order to detect change and to predict some future condition. An investigation of this kind is described for West and Central Africa by Olivry. The scientific momentum given to trend detection by environmental change has yielded a suite of trend detection methods and software. The future application of consistent methods of detection to long river flow time series around the world could represent an important integrating component between the different FRIEND groups, particularly where the issues of teleconnections and synchronicity are concerned. However, caution is required since, as pointed out by Dakova, man's influence has been substantial on river systems, and one must necessarily separate natural from man-induced change. This necessitates either the massive task of generating reduced-variance, or naturalised flow sequence, or else evolving analytical methods which account for non-stationarity.
4. Model applications : Complementing statistical methods of time series analysis, two of the presented papers discuss the application of time series simulation models, notably the Bilan and Modflow models with Northern Europe and the application of a modified PDM in Southern Africa. Other time series model applications have been developed within FRIEND, such as the Pitman model in Southern Africa and the Modglo model within West and Central Africa, as well as other models in previous European FRIEND reports. These models represent a hierarchy of models in terms of their scale of application, ranging from site specific calibrations of Modflow to sub-continental applications of PDM. By applying models to broader areas than the models were initially developed for, these activities address one of the underpinning philosophies of FRIEND to evaluate the performance of different models on different data sets. Ultimately, there must be future scope for cross-fertilisation of algorithms, models and concepts between the different FRIEND groups.
5. Environmental change : The use of physically-based models (e.g. MODFLOW) has enabled the interaction between transmissivity, storativity and low flow response to be modelled. Furthermore, by modelling the interaction between groundwater and surface water systems, this approach enables the impact of environmental change (land-use change, groundwater abstraction and climate change) on low flows to be estimated.
6. Low flow estimation at ungauged locations : Many of the techniques in the presented papers, and activities within FRIEND groups, can be oriented towards estimation at ungauged locations, but stop short of recommended design procedures which can be readily applied 'off-the shelf'. It appears that the emphasis which is emerging within FRIEND groups regarding this issue is that data (both time series and spatial) have been collated in a regionally consistent manner, with investigations of the applicability of different methods for estimation, but that the onus remains on national or other groups to pick up these data and results to carry them forward into specific design guidelines.

These six issues represent some central themes of the presented papers, but they do not encompass all FRIEND activities on this topic. The importance of low flows and drought in water management means that this topic has established a high profile within existing FRIEND programmes and it is likely to be a relevant and productive research area in the future.

ooooo

Les contributions présentées résument les actions menées dans quatre Groupes FRIEND sur les thèmes étiages et sécheresses. Il est utile de replacer ces travaux dans leur cadre plus général de FRIEND. Le Groupe NEF (antérieurement NWE), qui a démarré en 1986, a déjà publié deux rapports décrivant des travaux sur les étiages. Le premier (Gustard et al., 1989) contient des travaux sur les étiages dans ses

chapitres "Etudes regionales d'étiages", "Etudes sur bassins de recherche" et "Modéliser la réponse hydrologique aux influences humaines". Le second (Gustard, 1993) contient des travaux étiages dans les chapitres "Etiages" et "Variations des caractéristiques de régimes en rivière, à des échelles étendues". Chacun des trois autres Groupes (AMHY, SADC et AOC) a des travaux d'initiative plus récente, et qui n'ont pas encore fait l'objet de publications d'ensemble antérieures. On notera que ce thème est déjà présent dans les préoccupations des tous nouveaux Groupes Nil, HKH et Asie du Sud-Est.

Plusieurs préoccupations peuvent être extraites de ces contributions, et qui leur sont plus ou moins communes.

1. Détermination de la localisation, de la sévérité et de la durée d'une sécheresse : A l'heure actuelle, l'ensemble des quatre Groupes FRIEND peut accéder directement à des bases de données dont le total approche 7500 séries de débits journaliers dans plus de 50 pays dans deux continents. Avec les nouvelles initiatives FRIEND prises en Asie du Sud-Est, dans la région HKH et sur le Nil, on peut imaginer que vers l'an 2000 les bases FRIEND dans le monde rassembleront près de 10000 séries dans plus de 100 pays et sur quatre continents. L'accessibilité de telles données va permettre des occasions, jamais rencontrées, pour déterminer l'évolution historique des sécheresses et des étiages dans de vastes régions du monde. Des progrès significatifs ont déjà été faits dans les Groupes NEF et SADC (Afrique Australe) sur les approches statistiques régionales appliquées aux étiages et aux sécheresses, et qui concernent l'ensemble d'une grande région. Ces approches cherchent à comprendre quels sont les facteurs qui commandent le comportement des basses eaux, et elles peuvent conduire à des méthodes de prédétermination sur des sites non observés. Avec la perspective concrète d'un futur réseau de données disponibles en temps réel, grâce à l'initiative OMM-WHYCOS, un nouveau challenge est proposé aux hydrologues : déterminer la localisation et la sévérité d'une sécheresse en cours, et non plus seulement caractériser les probabilités de sécheresses à partir du passé. Un tel challenge exigera d'établir des liens avec les agences de l'eau pour alerter les décideurs en cas de survenue d'une sécheresse, et fera se développer le domaine scientifique de la prévision des écoulements en phase de sécheresse, dans le cadre de systèmes d'adduction d'eau. Deux des contributions présentées (Gustard, Bullock et al.) exposent les premiers développements dans cette direction, au travers d'une cartographie du degré de sévérité de sécheresses passées.

2. Développement et évolution des méthodes statistiques : Deux des contributions présentent des développements de méthodes statistiques adaptées aux sécheresses. Il s'agit du programme EXDEV de l'Institut tchèque d'hydrométéorologie (Gustard), et de l'adaptation du théorème des probabilités composées aux séries d'étiages comprenant des valeurs nulles (Bulu). On doit citer ici, quoique la contribution soit absente, l'adaptation des modèles dits QdF (débit-durée-fréquence) en crues à ces débits d'étiages, adaptation faite par l'Institut roumain d'hydrométéorologie (Adler et al, 1997), et qui aurait pu figurer dans ce chapitre. A l'évidence, nombre d'analyses de fréquence d'étiages sont fondées sur des principes statistiques et sur l'analyse des valeurs extrêmes. En 1985, l'OMM et l'UNESCO avaient collaboré dans le cadre d'un guide "Aspects hydrologiques des sécheresses". Compte tenu de ce que FRIEND est une contribution au PHI de l'UNESCO, et de ce qu'il y a un important usage des techniques d'analyse des sécheresses dans les nouveaux Groupes FRIEND, ce serait un bon pas en avant que de mettre à jour un tel document qui présente les bases statistiques de l'analyse des étiages et des sécheresses.

3. Analyses de tendances : Un intéressant aspect de l'analyse des sécheresses est celui de leurs éventuelles tendances, afin de les déceler et de pouvoir estimer des conditions futures. Une recherche de ce type est menée par Olivry pour l'Afrique Occidentale et Centrale. La dimension scientifique donnée aux problèmes de tendances par les changements de l'environnement, a mené à une série de méthodes et de logiciels pour les détecter. Une application future de méthodes robustes de détection pour de longues séries d'écoulements en rivières et dans le monde entier, pourrait représenter un important moyen d'intégration entre les Groupes FRIEND, et tout particulièrement vis à vis des phénomènes spatialement liés et synchrones. Cependant, des précautions sont à prendre, comme indiqué par Dakova, car les influences humaines sont significatives sur nombre de rivières, et il faut les

séparer des phénomènes plus naturels. Ceci exige soit de lourdes tâches de réduction des variances et de reconstitution de débits pseudo-naturels, soit des méthodes d'analyse qui peuvent tenir compte de la non-stationnarité.

4. Applications de modèles : En complément à ces analyses de synthèse des séries par des outils statistiques, deux des contributions discutent de l'application des modèles de simulation de séries temporelles, en particulier des modèles Bilan et Modflow dans le Groupe NEF, et d'un modèle PDM modifié dans le Groupe Afrique Australe. D'autres applications de modèles continus ont été faites dans FRIEND, comme celles du modèle Pitman en Afrique Australe, du modèle Modglo en Afrique Occidentale et Centrale, et d'autres citées dans les précédents rapports FRIEND. Ces modèles représentent une série hiérarchisable en terme d'échelle spatiale, allant des calibrations locales de Modflow, aux ambitions quasi-continentales de PDM. En appliquant certains de ces modèles à des échelles plus vastes que celles où ils ont été d'abord développés, on répond à une des finalités de FRIEND qui est l'évaluation des modèles à partir de jeux de données différents. Dans une phase ultérieure, on pourra alors réaliser des améliorations croisées des concepts, modèles et algorithmes entre divers Groupes FRIEND.

5. Changements dans l'environnement : L'utilisation de modèles à bases physiques (par ex. Modflow) a permis de formaliser les relations entre les transmissivités, les porosités et les comportements en étiages. En outre, en modélisant les relations entre nappes et rivières, on se permet d'estimer les impacts de changements du milieu (utilisation des sols, prélèvements dans les nappes, évolutions climatiques) sur les étiages.

6. Estimations des étiages en des sites non observés : Plusieurs des technique présentées dans les contributions, et des actions dans FRIEND, peuvent être orientées vers les estimations hors stations observées, mais buttent sur les procédures opérationnelles réellement exploitables en dehors de leur contexte. En fait, il apparaît que ce qui est le plus important dans les travaux issus des Groupes FRIEND est la cohérence régionale et la robustesse des données rassemblées (tant les temporelles que les spatiales), ainsi que l'attention apportée à l'applicabilité des méthodes. Mais il reste de la responsabilité des groupes nationaux ou autres, d'exploiter ces données et ces résultats, pour en déduire des règles et méthodes de dimensionnements spécifiques.

Ces six préoccupations ont été centrales pour les contributions présentées. L'importance des étiages et des sécheresses en gestion des eaux a conduit à ce que cette thématique soit fortement présente dans les programmes FRIEND actuels, et elle induira de même une recherche pertinente et productive dans le futur.

References of chapter 3

Références bibliographiques du chapitre 3

Adler M.J., Galéa G., Mercier G. : Modélisation de synthèse, et approche régionale, des régimes d'étiage du bassin hydrographique de la Loire (France) et du Crisu-Alb (Roumanie). *Cemagref-Lyon, Division Hydrologie Hydraulique, I.N.M.H. Bucarest, Roumanie. Article soumis à la revue Sciences de l'Eau.*

Bamba, F., Diabate, M., Mahe, G., Diarra, M. (1995) Bilans hydrologiques pour des affluents majeurs du fleuve Niger: le Bani, le Sankarani, le Tinkisso et le Milo. In Réunion FRIEND, Cotonou (Bénin) , dec 1995.

Bamba, F., Diabate, M., Mahe, G., Diarra, M. (1996) Rainfall and runoff decrease of five riverbasins of the tropical upstream part of the Niger river over period 1951-1989. XXI general Assembly of EGS, The Hague The Netherlands, May 1996.

Bricquet, J.P., Mahé, G., Bamba, F., Olivry, J.C. (1996) Changements climatiques récents et modification du régime hydrologique du fleuve Niger à Koulikoro (Mali). In « L'hydrologie tropicale: géoscience et outil pour le développement » IAHS publ. n 238.

Bulu, A., Cigizoglu, K., Cokgor, S. (1995) : Statistical analysis of low flows on Thrace region, *FRIEND-AMHY Conf.*, Thessalonique, Greece. AMHY annual report n° 5 (1995-96), Technical reports in Hydrology, UNESCO 1997.

Bulu, A., Clougour, S., Gicizoclu, H.K. (1995): Seminar AMHY, Thessalonike, 1995. Statistical Analysis of Low Flow on Thrace Region.

Clausen B., Elberling B. (1994) : Relations between Geology, Low Flows, and Water Chemistry on a Catchment Scale. Department of Earth Sciences, Aarhus University, Denmark.

Clausen B., Pearson C.P. (1996) : How extreme was the drought? Contribution to the Nordic Hydrological Conference 1996, Akureyri, Iceland, 13-15. Aug. 1996, *NHP Report*, 40(2), 608-615.

Clausen B., Rasmussen K.R. (1993) : Low Flow Estimation and Hydrogeology in a Chalk Catchment. *Nordic Hydrology*, 24, 1993, 279-308.

Cui Y.F., Demuth S., Leibundgut C.H. (1995) : Runoff separation using tracer. In: Solutions '95 - XXVI Congress of the International Association of Hydrogeologists, June 4-10, Edmonton, Alberta, Canada.

Demuth S. (1989) : Small Research Basin Studies. In: A. Gustard (ed.) *Flow Regimes from Experimental and Network Data (FRIEND)*. Volume I. Hydrological Analysis. Wallingford, 141-185.

Demuth S. (1993) : Untersuchungen zum Niedrigwasser in WestEuropa. *Freiburger Schriften zur Hydrologie*. Professur für Hydrologie an der Universität Freiburg, B 1, 202 pp.

Demuth S. (1994) : Regionalization of low flows using a multiple regression approach A review. *XVIIth Conference of Danube Countries*, 5. 7. Sept. '94, Budapest, Vol. 1, p. 115-122.

Demuth S., Destruelle M. (1997) : Optimierung eines Grundwassermeßnetzes mit dem Kriging-Verfahren - Fallstudie Böhlinger Kiesfeld (Singen/Bodensee). (published Feb. 97 in *Deutsche Gewässerkundliche Mitteilungen DGM*).

Demuth S., Hagemann I. (1993) : Case study of regionalising base flow in SW Germany applying a hydrogeological index. Gustard, A. (ed.) (*FRIEND Flow Regimes from International Experimental and Network Data*), Volume I: Hydrological Studies. Institute of Hydrology, Wallingford, 86-98.

Demuth S., Hagemann I. (1994) : Estimation of low flow parameters applying hydrogeological area information. In: FRIEND: Flow Regimes from International Experimental and Network Data. (*Proc. of the Braunschweig Conference*, Oct. 1993). *IAHS Publ. No.* 221, 151-157.

Demuth S., Heinrich B. (1996) : Temporal and Spatial Behavior of Hydrological Droughts in Southern Germany. FRIEND '97, 3rd Int. Conf. on FRIEND, Postojna, Slovenia, 30 Sept. - 3 Oct. 1997. (paper accepted).

Demuth S., Külls C. (1996) : Probability Analysis and Regional Aspects of Droughts in Southern Germany. IAHS '97, Fifth IAHS Scientific Assembly, 23 April - 3 May 1997, Rabat, Morocco, (paper accepted for publication in the Proc. (revised)).

Demuth S., Schreiber P. (1994) : Studying storage behaviour using an operational recession method. In: FRIEND: Flow Regimes from International Experimental and Network Data. (*Proc. of the Braunschweig Conference*, Oct. 1993). *IAHS Publ. no.* 221, 51-59.

Department of Water Affairs, Namibia (1992) Unit runoff map for Namibia. Hydrology Division, Department of Water Affairs, Republic of Namibia.

- Department of Water of Malawi (1986) National Water Resources Master Plan. Department of Water, Ministry of Works and Supplies.
- Direcao Nacional de Aguas/Departamento de Recursos Hidricos (1994) 'Actual situation of water resources management in Mozambique.' Relatorio No. 32/94, Maputo.
- Duranyildiz I., Oguz B. (1994) : Regional Drought Analysis. Istanbul Technical University, Civil Eng. Fac., Hydraulics Dept., Turkey.
- Fendekova M. (1995) : Factor Analysis of Catchment Characteristics. *J. Hydrol. Hydromech.*, 43, 1995, 4-5, 354-362.
- Fendekova M., Nemethy P. (1993) : Low Flows of Starohorský Brook and their Affecting Factors. In: FRIEND conf., Proc. of extended abstracts. Institut für Geographie und Geoökologie der TU Braunschweig, 53-54.
- Fendekova M., Nemethy P. (1994) : Low Flows of Starohorský Brook and their Affecting Factors. In: FRIEND: Flow Regimes from International Experimental and Network Data. (*Proc. of the Braunschweig Conference, Oct. 1993*). IAHS Publ. no. 221, 165-170.
- Fendekova M., Vous O. (1995) : Influence of Rock Environment and Groundwater Withdrawal on Groundwater Runoff. *Proc. of Conference: Geotechnical Problems of the Environment*. Slovak Technical University Bratislava, 97-102 (in Slovak)
- Gilyén Hofer A., Kovács G. (1994) : General Characterisation of low flows in Hungary. Water Resources Research Centre p.l.c. (VITUKI), Hungary.
- Gottschalk L., Tallaksen L.M., Perzyna, G. (1997) : Derivation of low flow distribution functions using recession curves. *J. Hydrol.* (In press).
- Gustard A., Bullock A., Dixon J.M. (1992) : Low flow estimation in the United Kingdom. Report No. 108, Inst. of Hydrology, Wallingford, UK.
- Gustard A., Roald L.A., Demuth S., Lumadjeng H.S., Gross, R. (1989) : *Flow regimes from experimental and network data (FRIEND)* Vol. I - Hydrological Studies, Institute of Hydrology, Wallingford, Oxon, UK.
- Hare-Kenneth, F. (1985) Les variations climatiques, la sécheresse et la désertification. OMMn 653
- Hubert, P., Carbonnel, J.P., Chauuche, A. (1989) Segmentation des séries hydrométéorologiques. Application à des séries de précipitations et de débits de l'Afrique de l'Ouest. *J. of Hydrol.*, 110, 349-367.
- Jennings, M.E., Benson, M.A. (1969) : Frequency curve for annual flood series with some zero events or incomplete data. *Water Resour. Res.*, 5(1), 276-280.
- JICA/Ministry of Energy and Water Development (1995) The study on the National Water Resources Master Plan in the Republic of Zambia.
- Kašpárek L., Krejčová K. (1994) : BILAN Water Balance Model. User guide and Background Information. T.G. Masaryk Water Research Institute, Prague, 19 pp.
- Kilmartin, R.F., Peterson, J.R. (1972) : Rainfall-runoff regression with logarithmic transforms and zeros in the data. *Water Resour. Res.*, 8(4), 1096-1099.
- Kupczyk E., Kasprzyk A., Radczuk L., Czamara W. (1994) : A study of low flow regimes of Polish rivers. In: FRIEND: Flow Regimes from International Experimental and Network Data. (*Proc. of the Braunschweig Conference, Oct. 1993*). IAHS Publ. no. 221, 133-140.
- Lamb, P. (1985) Rainfall in subsaharian West Africa during 1941-1983. *Z.Gletscherk Glazialgeologie* 21, pp.131-139.
- Lanen H.A.J. van, Clausen B., Kašpárek L. (1993) : Interaction between low flows and hydrogeology. In: A. Gustard (Ed.), *Flow Regimes from International Experimental and Network Data (FRIEND)*. Vol. I Hydrological Studies, Wallingford, 21-56.
- Lanen H.A.J. van, van de Weerd B. (1994) : Groundwater flow from a Cretaceous Chalk Plateau: Impact of groundwater recharge and abstraction. In: FRIEND: Flow Regimes from International Experimental and Network Data. (*Proc. of the Braunschweig Conference, Oct. 1993*). IAHS Publ. no. 221, 87-94.
- Lanen H.A.J. van, van de Weerd B., Dijkema R., ten Dam H.J., Bier G.. (1995) : Hydrogeology of the Noor catchment and the impact of groundwater abstraction. Report No. 57. Department of Water Resources, Wageningen Agricultural University, 152 pp (in Dutch).
- Laraque, A., Olivry, J.C. (1996) Evolution de l'hydrologie du Congo-Zaïre et de ses affluents rive droite et dynamique de se transports solides et dissous. In « L'hydrologie tropicale: géoscience et outil pour le développement » IAHS publ n 238.
- Leskova D., Majercakova O., Sedik P. The regional analysis of low flows. [The SHMI report to task P-04.] Bratislava, SHMI, 1993 (in Slovak)

- Liebscher H.-J., Lauterbach D., Herrmann A. (1993) : Physical processes of streamflow generation in small basins. International Research Programmes. - In: A. Gustard (ed.): *Flow Regimes from International Experimental and Network Data (FRIEND)*, Vol. I Hydrological Studies, 185-188, Wallingford.
- Madsen H. (1994) : On the Abstraction of Drought Events from Continuous Time Series. Institute of Hydrodynamics and Hydraulic Engineering, Technical University of Denmark.
- Mahé, G., Olivry, J.C. (1991) Les changements climatiques et variations des écoulements en Afrique occidentale et centrale du mensuel à l'interannuel. In *Hydrology for the Water Management of Large Rivers Basins*. IAHS Publ n 201, pp 163-172.
- Mahé, G., Olivry, J.C. (1995) Variations des précipitations et des écoulements en Afrique de l'Ouest et Centrale de 1951 à 1989. *Sécheresse*, n 1, vol. 6; 109-117
- Majercáková O., Šedík P., Lešková D., Cagardová _ (1994) : Low Flows. Report of Slovak Hydrometeorological Institute for working group Low Flows, FRIEND project, Slovak Hydrometeorological Institute, Bratislava, Slovak Republic.
- Majercakova O., Leskova D., Sedik P. (1995) : Selected characteristics of low flows of Slovak rivers. *J. Hydrol. Hydromech.*, 43, (in press)
- Majercakova O., Sedik P. (1994) : The selection of the hydrological series and the analysis of their reliability. The analysis of the hydrological series variability. [Report for National Climate Programme SR] Bratislava, SHMI, (in Slovak)
- Mandadgiev, D. (1996): The strategy of water management in Bulgaria.
- Mawdsley J., Petts G., Walker S. (1993) : Assessment of Drought Severity. *BHS Occasional Paper No.3*, British Hydrological Society.
- McDonald M.G., Harbaugh A.W. (1988) : A modular three dimensional finite difference groundwater flow model. *United States Geological Survey*.
- Ministry of Water Resources and Development of Zimbabwe (1984) An assessment of the surface water resources of Zimbabwe and guidelines for development planning.
- Ministry of Water, Energy and Minerals (1995) Rapid Water Resources Assessment of Tanzania. 2 Volumes. Dar es Salaam, Tanzania.
- Moore R.J (1985) The probability-distributed principle and runoff production at point and basin scales. *Hydrol. Sciences. J.*, 30, 263-297.
- Nemethy P., Fendekova M. (1993) : Influence of Groundwater Withdrawal on Low Flows Regime. *Proc. of Conference: Water Sources and their Protection*. Slovak Technical University Bratislava, 249-256. (in Slovak)
- Neto F.M. and Mendes P.E. (1996) Water resources management in Angola. Paper presented at the Sub-Saharan Water Resources Technical Workshop, Nairobi, Kenya. February 12-15, 1996.
- Olivry J.C. (1983) Le point en 1982 sur l'évolution de la sécheresse en Sénégal et aux Iles du Cap-Vert -Examen de quelques séries de longue durée (débits et précipitations). *Cahiers ORSTOM Paris*, Vol.XX, no 1, pp. 47-70.
- Olivry, J.C. (1976) Régimes hydrologiques en pays bamiléké (Cameroun). *Cahiers ORSTOM Paris*, série hydrologie, Vol.XIII, n 1, pp.37-71.
- Olivry, J.C. (1987) Les conséquences durables de la sécheresse actuelle sur les écoulements: Sénégal et Casamance. In *Proceedings of the Vancouver Symposium*. IAHS Publ. n 168, pp. 501-512.
- Olivry, J.C., Bricquet, J.P., Mahé, G. (1993) Vers un appauvrissement durable des ressources en eau de l'Afrique humide? *Proceedings of the Symposium « Hydrology of Warm Humid Regions » IAHS Sc.Assembly Yokohama July 1993*. IAHS n 216, pp. 66-78.
- Olivry, J.C., Chastanet, M. (1986) Evolution du climat dans le bassin du fleuve Sénégal (Bakel)
- Paturel, J.E., Servat, E., Kouame, B., Boyer, J.F., Lubes, H., Masson, J.M. (1996) Procédures d'identification de « ruptures » dans des séries chronologiques; modification du régime pluviométrique en Afrique de l'Ouest non sahélienne. In « L'hydrologie tropicale : géoscience et outil pour le développement » IAHS Publ. n 238.
- Radczyk L., Szarska O. (1989) : Use of the flow recession curve for the estimation of conditions of river supply by underground water. *IAHS Publ.*, No. 187, 67-74.
- Radic Z.M. (1994) : Droughts in Yugoslavia. FRIEND AMHY Group, Faculty of Civil Engineering, University of Belgrade.
- Radich, Z. (1994): Drought in Yugoslavia.
- Ricica J., Novický O. (1994) : Experiments with Deficit Volumes (EXDEV). Program description, edition December 1994, Czech Hydrometeorological Institute, Prague, Czech Republic.
- Ricica J., Novický O. (1995) : Experiments with deficit volumes (EXDEV). Description of the program. Edition April 1995. Czech Hydrometeorological Institute, Prague, 6 pp.

- Schreiber P., Demuth S., Leibundgut C.H. (1996) : Investigation of spatial low flow behaviour applying a river network approach. HYDROLOGIS '96, Wien 16-19. April '96, Poster Session Volume.
- Schumann S., Armbruster V., Demuth S. (1996) : Combined approach to investigate flow and transport in Karst Aquifers. IAHS Fifth Assembly Rabat, Marocco Workshop W2 «*Karst Hydrology*». (paper accepted).
- Singh V.P. (1989) : *Hydrologic systems vol. II*. Prentice Hall, New Jersey.
- Sircoulon, J. (1987) Variation des débits des cours d'eau et des niveaux des lacs en Afrique de l'Ouest depuis le début du 20ème siècle, in Proceedings of the Vancouver Symposium. IAHS Publ.n 168, pp.13-25.
- Sircoulon, J. (1989-) Bilan hydropluviométrique de la sécheresse 1968-84 au Sahel et comparaison avec les sécheresses des années 1910 à 1916 et 1940 à 1949 in Les hommes face aux sécheresses. Nordeste bresilien. Sahel africain. Coll. Travaux et Mémoires de l'IHEAL numéro 42, pp. 107-114.
- Sircoulon, J. (1990): Impact possible des changements climatiques à venir sur les ressources en eau des régions arides et semi-arides. WCAP n 12, 87 p. WRO/TD-N 380.
- Sircoulon, J., Olivry, J.C. (1986) Caractéristiques de la sécheresse actuelle en Afrique de l'Ouest et Centrale. Proc. of the Sahel Forum on 'The state-of-the-art of hydrology and hydrogeology in the arid and semi-arid areas of Africa', Unesco.
- Smakhtin V.Y. and Watkins D.A. (1997) Low flow estimation in South Africa. Water Research Commission, South Africa.
- Snowy Mountain Engineering Corporation Ltd., WLP Consultants and Swedish Geological International AB, (1991). Botswana National Water Master Plan Study. Final Report, Volume 6 - Hydrology. Government of Botswana, Ministry of Mineral Resources and Water Affairs, Department of Water Affairs.
- Tallaksen L.M. (1993) : Modelling land use change effects on low flows. In: A. Gustard (Ed.), *Flow Regimes from International Experimental and Network Data: Vol. I, Hydrological Studies*. Institute of Hydrology, Wallingford, Oxfordshire, UK, 56-58.
- Tallaksen L.M. (1995) : A review of baseflow recession analysis. *J.Hydrol.* 165, 349-370.
- Tallaksen L.M., Erichsen B. (1994) : Modelling low flow response to evapotranspiration. In: FRIEND: Flow Regimes from International Experimental and Network Data. (*Proc. of the Braunschweig Conference*, Oct. 1993). *IAHS Publ. no.* 221, 95-102.
- Tallaksen L.M., Hisdal H. (1997) : Regional analysis of extreme streamflow drought duration and deficit volume. Contribution to the 3rd Int. FRIEND Conf., Postojna, Slovenia, 30 Sept.-4 Oct., 1997.
- Tallaksen L.M., Madsen H., Clausen B. (1997) : On the definition and modelling of streamflow drought duration and deficit volume. *Hydrological Science Journal* (In press).
- Tallaksen L.M., Schunselaar S., van Veen R. (1996) : Comparative model estimates of interception loss in a coniferous forest stand. *Nordic Hydrology* 27 (3), 143-160.
- TCLFE (Task Committee on Low-Flow Evaluation) (1980) : Characteristics of low flows. *J.Hydraul. Div. ASCE*, 106 (HY5), 717-731.
- The Global Climate System Review (GCSR), WMO, UNEP, 1995.
- Wesselink A., Hagemann I., Demuth S., Gustard A. (1994) : Computer application of regional low flow study in Baden-Württemberg. In: FRIEND: Flow Regimes from International Experimental and Network Data. *IAHS Publ. No.* 221, 141-150.
- WRC (1994) Surface Water Resources of South Africa 1990. 13 Volumes. Water Research Commission
- Yevjevich V. (1967) : An objective approach to definition and investigations of continental hydrologic droughts. *Hydrology papers*, 23, Colorado State University, Fort Collins.
- Zelenhasic E., Salvai A. (1987) : A method of streamflow drought analysis. *Wat. Resour. Res.*, 23(1), 156-168.

Chapter 4

Floods

Short introduction

P. Versace

Flood hydrology has focussed a large interest all over the countries due to its social and economic impact. A noteworthy development of theoretical researches on flood dynamics has been observed in the last years. Moreover many attempts to define standard procedures as regards the design discharge and hydrograph, the identification of flooding prone areas, the safety level of hydraulic infrastructures, especially for dams, have been performed. It can be useful to remember the procedures suggested in the U.S.A. by the Water Resources Council, in the United Kingdom by the Natural Environment Research Council with the Flood Studies Report, in France by the Cemagref and the Electricité de France with the Gradex and the AGREGEE methods, in Italy by the Consiglio Nazionale delle Ricerche with the VAPI project.

Some of these procedures employed in different countries are analysed and compared in the FRIEND project. In this chapter some results obtained by the various research teams involved in FRIEND project, as regards flood hydrology, are described.

Lang shows some details about a new progressive option and confidence interval of the quantiles for the AGREGEE model, providing new developments in POT (peaks over threshold) sampling techniques and the use of historical information. Finally a comparison among AGREGEE model and other flood frequency methods (TOPMODEL, modified rational method, PMP/PMF) is presented. Blazkova et al. validate the AGREGEE approach using the frequency version of TOPMODEL within the Generalized Likelihood Uncertainty Estimation (GLUE) framework through synthetic generation of flood peaks. Mkhanda summarises some results of the analysis of flood statistics and frequency growth curves derived for the countries of the southern Africa through a comparative study on flood characteristics, in which the statistical robustness of LP3 and P3 distributions has been tested. Versace and Ferrari deal with a regional flood frequency approach based on a modified index flood method, that can be framed into three hierarchical levels of regional analysis, combining successfully rainfall and flood informations. The flood distributions considered for the hierarchical approach are the TCEV and GEV models. A case study of the TCEV regional procedure with reference to Italian basins is presented. Oancéa et al. show the results of the analysis of the synthetic hydrograph computing methods performed using the Synthetic Mono-Frequency Hydrograph method, as a part of the INONDABILITÉ model, and a Romanian hydrological service method (NIMH). Vukmirovic and Petrovic review the theoretical background of the classical distributions used for the analysis of the number of POT (Poisson, Bernoulli) and of peak exceedance (exponential, Weibull) combined to obtain distribution functions of peak flow. An application of the POT analysis is also shown. Stanescu describes the large floods of the recent past in Europe paying attention separately to large basins, particularly to Danube and Rheno rivers, medium size basins and flash floods. As a result of the study, the return period for the examined flood events is given. Ferrer and Ardiles provide some deepening around the modified rational method, particularly suitable for use in regional hydrology and its implementation in geographic information system environments. Moreover a comparison between the modified rational method and the AGREGEE method is presented.

Brève introduction

P. Versace

L'hydrologie des crues a fait l'objet d'un large intérêt dans tous les pays par suite de son intérêt socio-économique. Un développement notable de recherches théoriques autour de la variabilité des crues a été observé ces dernières années. En outre, ont été entrepris des essais de normalisation pour les procédures d'estimation des débits et hydrogrammes de projet, de délimitation de zones inondables, et de niveaux de sécurité des ouvrages hydrauliques (surtout pour les barrages). Il est utile de citer ici les procédures recommandées aux USA par le Conseil des ressources en eaux, au Royaume-Uni par le Conseil de recherche sur l'environnement naturel avec le Rapport sur les études de crues, en France par le Cemagref et EDF avec les méthodes GRADEX et AGREGEE, en Italie par le Conseil national de la recherche avec le projet VAPI.

Quelques unes de ces procédures nationales font l'objet d'analyses et de comparaisons dans le projet FRIEND. Dans ce chapitre, sont décrits quelques-uns des résultats obtenus par diverses équipes de FRIEND autour de ces problèmes d'hydrologie des crues.

Lang donne quelques détails sur une nouvelle option progressive et sur les intervalles de confiance des quantiles dans le modèle AGREGEE, ainsi que sur de nouveaux développements en échantillonnage de valeurs supérieures à un seuil et en exploitation des données dites historiques. Des résultats de comparaisons entre AGREGEE, TOPMODEL, la nouvelle méthode rationnelle MRM et les procédures PMP/PMF sont également présentés. Blazkova et al. valident l'approche AGREGEE en exploitant les simulations de pointes de crues sous procédure GLUE (estimation des incertitudes via un maximum de vraisemblance généralisé) de la variante dite statistique de TOPMODEL. Mkhandi résume quelques résultats d'analyses statistiques et de coefficients de croissances de crues, pour les pays d'Afrique australe, au travers de comparaisons de caractéristiques, et où les robustesses des lois LogPearson3 et Pearson3 ont été soigneusement testées. Versace et Ferrari traitent d'une approche régionale de fréquences de crues basée sur une méthode d'index de crue adaptée, laquelle peut être structurée en trois niveaux hiérarchisés d'analyses régionales, combinant avec succès des informations de pluies et de débits. Les distributions de crues considérées pour ces approches hiérarchisées sont les doubles exponentielles de type TCEV et les extrêmes généralisées GEV. Un exemple de la procédure régionale sous TCEV est présentée sur des bassins italiens. Oancéa et al. montrent les résultats issus de l'analyse comparée d'hydrogrammes synthétiques telle qu'elle existe dans le modèle INONDABILITE (HSMF : Hydrogramme Synthétique Mono-Fréquence) ou dans une procédure de l'Institut d'hydrologie (INMH) roumain. Vumkirovic et Petrovic reprennent les bases théoriques des distributions les plus classiquement utilisées pour les nombres de valeurs supérieures à un seuil (Poisson et Bernoulli) et les volumes de dépassement (exponentielle, Weibull), combinées pour avoir des distributions de pointes de crues. Une application est également faite. Stanescu décrit les grandes crues les plus récentes en Europe, en distinguant les grands bassins (Danube, Rhin) des moyens et de ceux à crues éclairs. Il en déduit leurs niveaux fréquentiels régionaux. Ferrer et Ardiles fournissent quelques approfondissements autour d'une méthode rationnelle modifiée (MRM), particulièrement adaptée à un usage régional et à une implantation sous un environnement de type SIG. En plus, une comparaison est faite entre cette MRM et AGREGEE.

New developments with AGREGEE, a statistical model using hydro-meteorological information

Nouveaux développements sur AGREGEE, un modèle statistique utilisant l'information hydrométéorologique

M. Lang

1 Introduction

Each year extreme floods cause severe economic and human damage. Two kinds of actions can reduce the flood risk. Short-term actions, based on flood forecasting, allow people to be warned (a few hours to several days operational delay before flooding). Midterm to long-term actions, based on statistical flood studies (that give better knowledge of sensitive risk areas) propose structural or land use actions against floods.

These two complementary actions use available hydrometeorological information. The AGREGEE model is a tool devoted to midterm and long-term actions, and it is used to estimate flood quantiles, relative to fixed exceedance probability.

Many hydrological methods give flood quantile estimates :

- simple or multi-linear regression can explain the value of a flood quantile, with a few parameters such as the catchment area, a rainfall parameter, and other catchment characteristics.
- flood frequency methods fit the parameters of the distribution, from a sample of maximum values. The fitting is carried out on flood records for one site (single site analysis), or on all data from a homogeneous region (regional analysis) by pooling floods divided by the mean annual flood.
- rainfall-runoff analyses use a probabilistic approach like the GRADEX or AGREGEE method, or a real-time approach by transferring a rainfall event to a flood event.

The AGREGEE model uses several sub-models regarding the frequency domain :

- the observable domain is the portion of the frequency curve estimated from observed flood data,
- the extreme domain is under control of the rainfall frequency curve,
- the rare domain is an intermediate domain and has to link the two preceding ones continuously.

The aim of the AGREGEE model is to improve the quantile estimates, by making best use of the hydrological information available. It involves :

- extracting the maximum flood values for several durations, from one hour to several days ;
- extracting not only the annual maximum values of the continuous period of measurement, but also the over-threshold values from the continuous period and the historical period ;
- working at a regional scale;
- using not only flood data but also rainfall data.

After a presentation of the main assumptions of the AGREGEE model and the specific tools used for each frequency domain, we present some new developments since the last four-year FRIEND Report (Saelthun and Oberlin, 1993).

2 Assumptions

The AGREGEE model (Margoum, 1992 ; Oberlin et Margoum, 1993 ; Margoum et al., 1994) uses three assumptions :

- the first is that the rainfall frequency curve is asymptotic to an exponential law,
- the second is that, when the catchment is close to saturation, each increase of rainfall dP induces an equivalent increase of discharge dQ (volumes dP and dQ are calculated on the same duration d),
- the third is a determination of synthetic hydrographs, with the quantile estimates of instantaneous flood QIX and threshold floods $QCXd$.

The mathematical formulation of these three assumptions is as follows :

- (i) $a_p(T) = a_e \cdot T / (T + K_p) \quad \forall T > T_g$
- (ii) $a_q(T) = a_p(T) \cdot T / (T + K_q) \quad \forall T > T_g$
- (iii) $F(QIX) = \iint f(VCXd, RXd) \cdot d(VCXd) \cdot d(RXd) \quad \text{with } RXd = QIX/VCXd$
 $F(QCXd) = \iint f(VCXd, CXd) \cdot d(VCXd) \cdot d(CXd) \quad \text{with } CXd = \text{Log}(VCXd/QCXd)$

where :

- the gradex $a_p(T)$ or $a_q(T)$ is defined as the slope of the rainfall distribution $F(P)$ or discharge distribution $F(Q)$ with a logarithmic axis on return period T : $a_p(T) = dP(T) / d\text{Log}T$ and $a_q(T) = dQ(T) / d\text{Log}T$
- the maximum average discharge distribution $F(VCXd)$ is extrapolated by (i) and (ii)

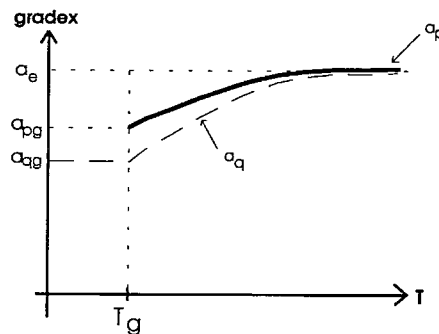

Figure 1 : Rainfall and discharge gradex versus the return period

Figure 1 : Variations du gradex des pluies et des débits avec la période de retour

The main explanations for the three basic hypotheses are the following.

. First assumption

Many studies indicate a good agreement between the experimental maximum daily rainfall frequency curve and a Gumbel distribution. It is one of the assumptions of the GRADEX method (Guillot and Duband, 1967; CFGB, 1994). The AGREGEE model permits use more general distributions with three parameters, but keeps the constraint of an asymptotic gradex. This kind of distribution can be used with compound Gumbel seasonal rainfall distribution or with areal rainfall distribution. For short-time rainfall intensities, skewed distributions may be obtained.

. Second assumption

The probability of a flood volume Q comes from combining a random probability of rainfall P and its associated random retention loss D . For large precipitations, the retention loss does not increase after the saturation of the catchment. So it induces an asymptotic parallelism between the rainfall distribution $F(PXd)$ and the maximum average discharge distribution $F(VCXd)$, for large return periods.

. Third assumption

The determination of the peak discharge distribution $F(QIX)$ and the threshold distribution $F(QCXd)$ cannot be based on volume considerations, as was the previous assumption between rainfall and discharge volumes. So the AGREGEE model incorporates certain theoretical results of the calculation of a bivariate distribution. It combines the maximum volume discharge $VCXd$ with the ratio RXd , defined as : $RXd = QIX/VCXd$, or $RXd = \text{Log}(VCXd/QCXd)$.

The general mathematical formulation of the AGREGEE quantiles is as follows :

$$Q(T) = Q(T_g) + \frac{a_e}{K_p - K_q} \cdot \left(K_p \cdot \text{Log} \frac{T + K_p}{T_g + K_p} - K_q \cdot \text{Log} \frac{T + K_q}{T_g + K_q} \right) \quad \text{with } T \geq T_g \quad (1)$$

with : $K_p = (a_e/a_{pg} - 1) \cdot T_g$ and $K_q = (a_{pe}/a_{qe} - 1) \cdot T_g$

If the rainfall distribution is a simple exponential law or a Gumbel law, we find the following formula, called « aesthetical gradex » (Michel, 1982) :

$$Q(T) = Q(T_g) + a_p \cdot \text{Log} \left[1 + (a_{qg}/a_p) \cdot (T - T_g) / T_g \right] \quad \text{with } T \geq T_g \quad (2)$$

from Equation (1), with $a_p(T) = \text{const.} = a_p$, so : $K_p = 0$.

3 Flood domains

The AGREGEE model has three domains (Fig. 2) :

- the first is the observable domain, with discharge knowledge and sometimes historical discharge knowledge, if available,
- the third is the extreme domain, with rainfall gradex knowledge,
- and the second is the rare domain, which links the two preceding ones continuously.

3.1 First domain

The first domain is based on discharge information. A single site analysis can provide an estimation of flood distribution parameters. Because of the limited amount of information in a single annual maximum flood series, the extrapolation of the distribution towards large return periods gives very inaccurate estimates.

So a first improvement concerns the data sampling : with the renewal approach it is possible to select more data than one maximum value per year. On the other hand, the historical approach takes into account the available information preceding the period of regular observations. The AGREGEE software allows the use of both over-threshold values and historical values. The upper limit of the first frequency domain, usually taken as T_g equal to 10 to 50 years with annual maximum values, can be raised to 50 to 100 years if alternative sampling techniques are used.

A second improvement concerns regional analysis. This approach is based on the concept of regional growth curves, usually calculated with reduced floods (floods divided by the mean annual flood). The AGREGEE software does not use this approach; but it could be a future improvement for this first domain.

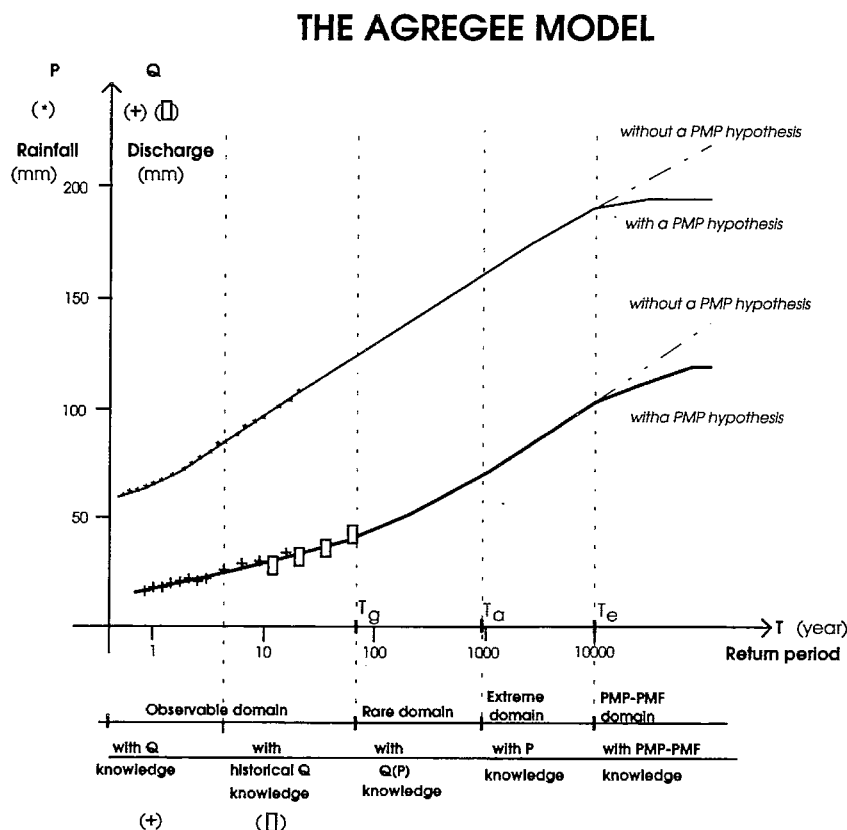

Figure 2 : Domains studied by the AGREGEE model
Figure 2 : Domaines d'étude du modèle AGREGEE

3.2 Third domain

The third domain is based on rainfall information. It is very difficult to make a validation of the extreme flood quantile estimates, because by definition very few extreme events have been observed. So the discussion concerns the basic assumptions. The second assumption of AGREGEE has good physical foundations and is generally accepted. The first assumption of AGREGEE can give various results regarding the choice of a single site or regional site analysis for rainfall. So there is a strong link between the knowledge of extreme rainfalls and the improvement of the extreme flood estimates.

3.3 Second domain

The second domain is an intermediate domain that links the two preceding ones. This is the most complex domain, which is under the influence of initial saturation conditions, air temperature, catchment physiographic characteristics and rainfall intensities. The operational sub-model of AGREGEE uses the mathematical formulation (ii), that links continuously discharge pseudo-gradex, between the upper value of the first domain (a_{g_1}) and the asymptotic rainfall gradex (a_g) (see Fig. 1).

4 New developments with the AGREGEE model

The previous four-year FRIEND Report presented the new AGREGEE model. Some complementary work has been started three years after, concerning :

⇒ the first frequency domain

- the use of the over-threshold sampling techniques, to improve the extraction of information from the data series

⇒ the second frequency domain

- the use of historical information, to test the mathematical formulation (ii)
- the use of another production function, called « progressive option » of AGREGEE, with better physical foundations
- a comparison between quantile estimates, from the AGREGEE method and other frequency analysis

⇒ the third frequency domain

- a calculation of the confidence interval of flood quantiles, with or without rainfall information
- a comparison between PMP/PMF estimates and AGREGEE flood quantiles

4.1 Over-threshold sampling techniques

The over-threshold sampling technique deals with the choice of a threshold S , and the selection of all flood X_s above this level. The analysis of the flood distribution considers the study of the flood process (the random occurrences m_t of the number of exceedances during a period of duration t) and the distribution of their magnitudes (over-threshold values' distribution $G_s(x)$). The main advantage of this sampling technique is to select more information from the data series. Because one year may contain several floods that all exceed the annual maximum in other years, the annual maximum sampling technique is less appropriate than the over-threshold sampling technique for describing the process of extreme events.

Two difficulties are specific to this sampling technique : the choice of a threshold S and the use of additional parameters that modelise the occurrence process. Lang (1995a) made a review of the available criteria for the choice of a threshold. A too low threshold induces the selection of dependant values, that induces a bias in the flood process study. A too high threshold induces the selection of not enough floods, that decreases the accuracy of the flood estimate. So a general result is that the threshold S must be chosen :

- as the mean number of threshold values $E(m_t)$ is larger than two values per year,
- as the mean excess above the threshold $(\bar{X}_s - S)$ does not change with the threshold,
- as the experimental dispersion index \hat{I}_t is located within the limits of the 90% confidence interval $[I_t(0.05) ; I_t(0.95)]$, where : $I_t = \text{Var}(m_t)/E(m_t)$.

The study of the flood process is usually made on the assumption of a Poisson distribution, with one parameter μ : $\text{Prob}(m_t = k) = \exp(-\mu.t).(\mu.t)^k/k!$ with $\hat{\mu} = E(m_t)/t$.

An alternative to the Poisson process can be :

- the negative Binomial distribution

$$\text{Prob}(m_t = k) = C_{\gamma t + k - 1}^k \delta^\gamma . (1 - \delta)^k \quad \text{with } \hat{\gamma} = \hat{\mu} / (\hat{I}_t - 1) \text{ and } \hat{\delta} = 1 / \hat{I}_t$$

- the Binomial distribution

$$\text{Prob}(m_t = k) = C_{\gamma t}^k \delta^k . (1 - \delta)^{\gamma t - k} \quad \text{with } \hat{\gamma} = \hat{\mu} / (1 - \hat{I}_t) \text{ and } \hat{\delta} = 1 - \hat{I}_t$$

In the case of a process distribution, the χ^2 test is usually not very accurate for the choice of a distribution : it is difficult to divide the sample of the number m_t at least into 5 classes with at least 7 or 8 elements. Two other statistics can give rise to discussion :

⇒ the dispersion index I_t

as the Poisson process has a dispersion index equal to unity :

- if $\hat{I}_t \in [I_t(0.05) = \chi^2(0.05) / (NY - 1) ; I_t(0.95) = \chi^2(0.95) / (NY - 1)]$,
a Poisson process can be used (NY is the number of years of the record period)
- if $\hat{I}_t < I_t(0.05)$ a Binomial distribution can be used
- if $\hat{I}_t > I_t(0.95)$ a negative Binomial distribution can be used

⇒ the return duration θ (duration between two successive occurrences of flood X_s)

as the theoretical distribution of θ is an exponential distribution : $\text{Prob}(\theta < d) = 1 - \exp(-d/\alpha)$, when

- $1/\hat{\alpha} = E(m_t)/t$ with a Poisson process,
- $1/\hat{\alpha} = (\text{Log} \hat{I}_t / (\hat{I}_t - 1)) \cdot E(m_t)/t$ with a negative Binomial or Binomial process,

it is possible to plot the experimental distribution θ against the theoretical exponential distribution.

Some authors, such as Cunnane (1973), Tavares and Da Silva (1983), Rosbjerg (1985) and Wang (1991), made a comparison of the sampling variance of quantiles, from a distribution of annual maximum (F_x) or over-threshold values (G_s). They found a small advantage of the distribution F_x when $\mu = 1$, an advantage of distribution G_s when $\mu > 1.7$, and similar results for rare events ($T > 10$ years). So, if this over-threshold sampling technique gives an improvement in the first frequency domain, additional information must be used for larger return periods.

A last important point concerns the possibility of selection of over-threshold values calculated on any durations. Usually hydrologists work with daily time series and give over-threshold values, calculated on the daily duration. It means only one duration, with a calendar maximum value (not a centred maximum value). As with the rainfall intensity-duration studies, it is important to consider not only the peak over-threshold values, but also the maximum values on any duration (from a few hours to several days). The classical procedure of over-threshold values' selection gives no coherence between the threshold S and the over-threshold values X_s , because the former is an instantaneous value, as the latter is an average discharge calculated on duration d .

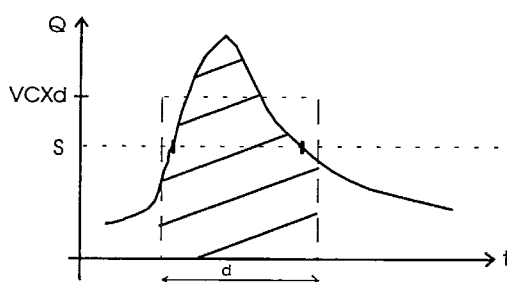

Figure 3 : Example of no selection of an over-threshold value VCXd

Figure 3 : Exemple de non-sélection d'une valeur sup-seuil VCXd

Figure 3 gives an example when the classical sampling technique does not give some value (because the duration of the episode is smaller than the duration d), although there exists a discharge $VCXd$ larger than the threshold S . Lang (1995b) proposed a new technique of threshold sampling, that allows all over-threshold values to be selected and to have a same meaning between a threshold S and values X_s (mean average discharge on duration d). The problem is divided into two steps :

- transformation of the basic time series $Q(t)$ into a provisional time series of average moved time series $Qd(t)$, as
$$Qd(t) = \int_{t-d/2}^{t+d/2} Q(\tau) \cdot d\tau,$$
- over-threshold values selection from the provisional time series $Qd(t)$.

An example with the time series of the French hydrometric station of La Foulerie, river La Hoëne [1979; 1991] ($A = 76 \text{ km}^2$) shows (see Fig. 4) the basic time series and the provisional time series that will be used. With the same threshold ($S = 1.5 \text{ m}^3/\text{s}$), the extraction during the period [day 30 ; day 40] in 1980 gives 5 over-threshold values of maximum instantaneous discharge and 2 over-threshold values of maximum 24 hours discharge (see Fig. 5).

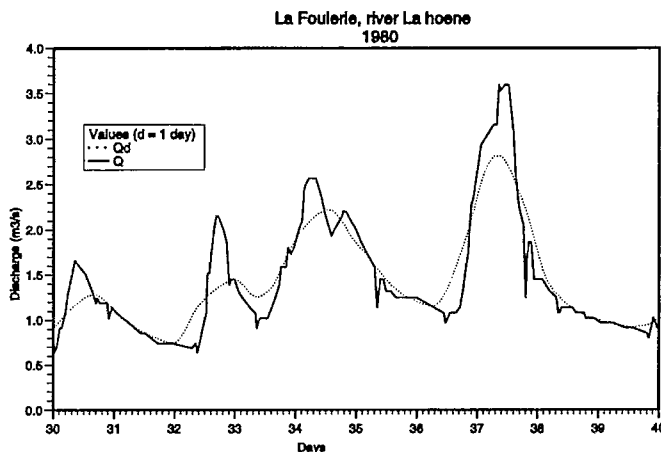

Figure 4 : Basic time series Q and average moved provisional time series Qd

Figure 4 : Visualisation de la chronique de base Q et de la chronique de moyenne mobile Qd

4.2 Use of historical information

The flood hazard study takes into account the past measurements of floods. Usually, hydrologists use information of the conventional gauging network, developed after the second world war. This continuous daily flows information produces a sample of the most important floods (usually about ten or twenty values). Because this continuous information does not give a good estimation of flood hazard, it is necessary to use previous information, called historical information, to improve flood analysis. This kind of information is usually not exhaustive (only the major floods remain known) and difficult to find (many sources). Another problem concerns the accuracy of historical flood estimates : hydrologists have to convert the historical levels into flood flows with hydraulic considerations. Usually the historical flood errors are greater than gauging flood errors.

That is why this kind of information is always under-used. However, some authors have made special studies of historical sources for hydrological design, as Frances et al. (1994). The AGREGEE model uses over-threshold values, with the method presented by Miquel (1984). The parameters of the distribution are fitted with the maximum likelihood method. The likelihood function has two components $V = V_1 \cdot V_2$.

The first component V_1 is relative to the continuous period of measurements : NF1 floods X_s (x_1, \dots, x_{NF1}) are larger than a threshold S , during $N1$ years. With $m_i =$ number of floods X_s in the year $n^\circ i$; $w_k(t) = \text{Prob}(k \text{ floods } X_s \text{ during } t \text{ years})$; $G_s(x) = \text{Prob}(X_s < x)$; $g_s(x) = \partial G_s / \partial x(x)$, it gives :

$$V_1 = \prod_{i=1}^{N1} w_{m_i}(1) \cdot \prod_{j=1}^{NF1} g_s(x_j)$$

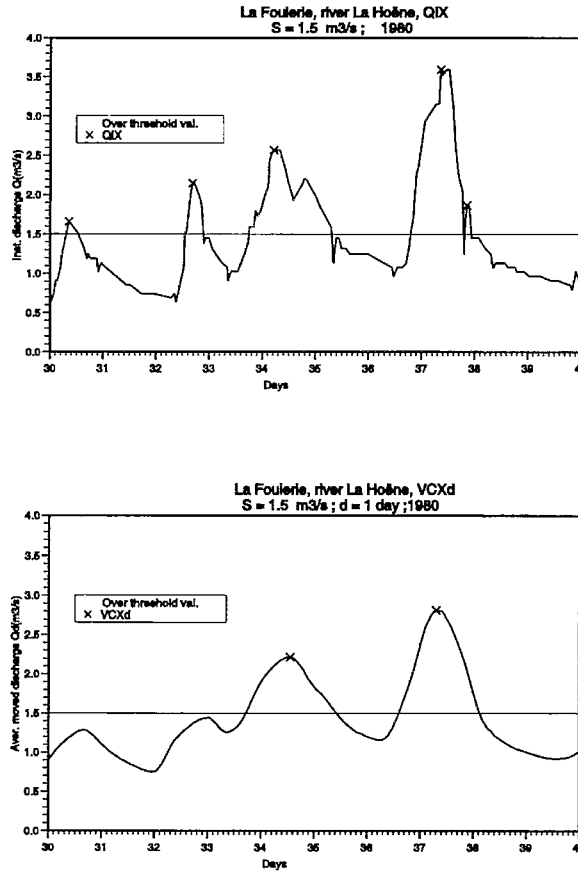

Figure 5 : Over-threshold values of instantaneous discharge QIX and average discharge $VCX24h$
Figure 5 : Valeurs sup-seuil en débit de pointe QIX et en débit moyen maximum $VCX24h$

The second component V_2 is relative to the historical period : the $NF2$ largest floods X_s ($y_1 > \dots > y_{NF2}$) are known, during $N2$ additional years.

$$\begin{aligned}
 V_2 &= \sum_{i=0}^{\infty} \text{Prob}(i \text{ floods smaller than } y_{NF2} \text{ among } (i + NF2) \text{ floods } X_s \text{ during } N2 \text{ years}) \cdot \prod_{j=1}^{NF2} g_s(y_j) \\
 &= \sum_{i=0}^{\infty} w_{i+NF2}(N2) \cdot \frac{(i + NF2)!}{i!} \cdot G_s(y_{NF2})^i \cdot \prod_{j=1}^{NF2} g_s(y_j)
 \end{aligned}$$

With a Poisson process (with parameter μ), it gives :

$$\begin{aligned}
 V_1 &= \lambda \cdot \mu^{NF1} \cdot \exp(-\mu \cdot N1) \cdot \prod_{j=1}^{NF1} g_s(x_j) \\
 V_2 &= (\mu \cdot N2)^{NF2} \cdot \exp[-\mu \cdot N2 \cdot (1 - G_s(y_{NF2}))] \cdot \prod_{j=1}^{NF2} g_s(y_j)
 \end{aligned}$$

Miquel (1984) showed, with Bayesian consideration, that the length of the 70% confidence interval can be divided by two with the use of historical information. He compared in his example the variance of the 1000 year flood quantile, with 16 years of continuous measurement on the river Moselle (Hauconcourt) in two cases : with or without the knowledge of the six largest floods that occurred in the preceding 112 years.

So, use of historical information can improve the first frequency domain of AGREGEE. In this case, the upper limit T_g can be raised to 50 to 100 years. Historical information can also be used as control information for the second frequency domain of AGREGEE. This is a new study that began in 1996, on river Guiers in France (near Grenoble). Collaboration between hydrologists and historians will allow historical information since 1700 to be collected and reviewed. This river was the old borderline between France and the Savoy, and many documents and reports are available. Attention will be paid to uncertainty due to conversion between stage level and discharge. Comparison between the experimental historical distribution and the AGREGEE estimates will also be possible, because the catchment area of the river Guiers (617 km²) is not too large and permits the estimate of an areal rainfall. Generally, historical flood information was collected for large basins (more than 10 000 km²) where the AGREGEE model cannot be easily used.

4.3 A new progressive option for the AGREGEE model

The second frequency domain of AGREGEE links the observable domain of floods and the extreme domain continuously. It uses the mathematical formulation (ii), called « aesthetical » option of AGREGEE. Margoum (1992) also made several attempts to find another option, that uses rainfall-runoff functions. The first attempt used the United States Soil Conservation Service function (USSCS, 1985). If the SCS equation for rainfall excess uses the same loss limit concept as the gradex method, the quantiles of extreme flood are underestimated, because the system moves too slowly to a saturation state.

So, another attempt, presented by Kayhanfard and Oberlin (1995), uses a production function called « Lorent reservoir ». The storage quantile, defined as $S(T) = P(T) - Q(T)$, has an exponential behaviour :

$$S(T) = S(T_g) + [S_{\max} - S(T_g)] \cdot \left[1 - \exp\left(-K \cdot \frac{P(T) - P(T_g)}{S_{\max} - S(T_g)}\right) \right] \quad (3)$$

$$\text{with : } K = 1 - a_{pg} / a_{qg} \quad \text{and} \quad \text{Log} \frac{S_{\max} - S(T_g)}{S_{\max} - S(T_{ge})} = K \cdot \frac{P(T_{ge}) - P(T_g)}{S_{\max} - S(T_g)} \quad (4)$$

The method links the first frequency domain ($T < T_g$), with estimates of parameters a_{qg} , a_{pg} , $S(T_g)$, $P(T_g)$, and the third frequency domain ($T > T_{ge}$), with estimates of the rainfall $P(T)$, $P(T_{ge})$, and the storage S_{\max} and $S(T_{ge})$. The maximum capacity of storage S_{\max} is estimated from equation (4), with an iterative procedure, and the following assumption : $S(10\ 000 \text{ years}) = 0.99 S_{\max}$. While this progressive option uses a more physically based function and gives similar results as the aesthetical one, some complementary work is necessary to improve the estimate of the storage capacity of the catchment.

4.4 Comparison between the AGREGEE model and other frequency methods

In the last four-year FRIEND Report, Saelthun and Oberlin (1993) presented some results concerning an intercomparison of flood estimation techniques (on six British catchments and five Norwegian catchments). A comparison of the index flood analysis and the AGREGEE model showed a good correspondence for catchments where the losses are moderate in the first frequency domain. For catchments with large losses, the AGREGEE model gives higher quantile estimates, due to the hypothesis of an asymptotic parallelism between rainfall and discharge distribution. A similar comparison began in 1996, with the use of the VAPI model (see Ferrari and Versace, 1995). Ferrari (1996) presented a first draft concerning a sensitive analysis of the AGREGEE parameters, as the threshold return period T_g and the rainfall gradex a_p . More details will be presented in 1997 at the four-year general FRIEND Conference in Slovenia.

Ferrer and Ardiles (1995) made the comparison of peak discharges, with the Modified Rational Method (MRM), on seven French catchments. The relative difference between MRM and AGREGEE 100 year or 500 year quantiles is generally less than 20 %. The MRM method gives more conservative results. A collaboration between the Masaryk Institute (Czech Republic, Prague) and the Cemagref Institute (France, Lyon) began in 1996. The work concerns the frequency version of TOP MODEL (see Blazkova and Beven, 1994) and the AGREGEE model, on three small catchments in the Jizera Mountains (Czech Republic) and three larger catchments in France.

So, at this moment, the comparison between the AGREGEE model and other frequency methods concerns only a few basins. In the coming years, the aim is to compare these several methods on a large number of catchments, to find the advantages and disadvantages of each method, and to try to build some general tool that makes best possible use of the available information.

4.5 Confidence interval of the AGREGEE quantiles

Lang (1995b) made the theoretical calculation of the 95% confidence interval with three assumptions : the simple case when the rainfall gradex is constant (aesthetical gradex), the classical hypothesis of normality of quantile distribution, and the variance estimation by Tailor series expansion. He used the Swiss long discharge series of the river Inn at St Moritzbad [1907;1987] and the rainfall site N° 378, with records for 25 years. The determination of the quantile estimates and the confidence interval is made in two cases. In the classical case, a Pearson type III distribution is fitted from the discharge series, with the calculation of the theoretical variance. In the alternative case, the AGREGEE model has two parts ($T_g = 10$ years) : if $T < T_g$, a Gumbel distribution is fitted from the discharge series, if $T > T_g$, the distribution is extrapolated with the rainfall gradex, estimated from the rainfall series with a Gumbel distribution.

Table 1 shows that, even if the AGREGEE model uses discharge information only until a return period of 10 years and extrapolates afterwards with the rainfall gradex, the two estimates have the same accuracy, despite the use of 81 years of discharge information with the Pearson type III distribution. The quantile $Q(1000)$ has for example a confidence interval $I_{95\%} = [96;157]$ with the AGREGEE model, and $I_{95\%} = [54;129]$ with a Pearson type III distribution.

Table 1 : Comparison of flood quantiles, AGREGEE model - Pearson type III (81 years)

Table 1 : Comparaison des quantiles de crue, modèle AGREGEE - loi Pearson type III (81 ans)

T		10	50	100	500	1000
$\hat{Q}(T)$	AGREGEE	49.7	68.4	80.2	111.7	126.2
	Pearson III	50.6	64.6	70.8	85.1	91.4
$\text{Var}\hat{Q}(T)$	AGREGEE	4.4	21.8	44.6	160.3	240.4
	Pearson III	5.7	36.7	73.4	245.4	367.2

If we now make the calculation of the confidence limits with 25 years of discharge, which is a common case, Table 2 and Figure 6 show the width of Pearson type III quantile confident limits is twice that of the AGREGEE limits.

Table 2 : Comparison of flood quantiles, AGREGEE model - Pearson type III (25 years)

Table 2 : Comparaison des quantiles de crue, modèle AGREGEE - loi Pearson type III (25 ans)

T		10	50	100	500	1000
$\text{Var}\hat{Q}(T)$	AGREGEE	14.1	54.6	94.8	258.6	360.3
	Pearson III	18.4	118.9	237.7	795.2	1190.

This theoretical calculation pleads in favour of the use of an additional information such as rainfall information. It reduces the uncertainty of the quantile estimates.

4.6 Comparison between PMP/PMF and AGREGEE estimates

The PMP/PMF method uses the concepts of Probable Maximum Precipitation and Probable Maximum Flood. Desurosne et al. (1993) made a comparison of this approach with the AGREGEE model. The PMP was estimated with the Hershfield method (1961) and the PMF with the rational method, on 4 catchments (one in France, two in Romania, one in Switzerland), for several flood durations (1, 2, 3, 5 and 10 days). The AGREGEE model gives an estimate of the return period of the PMF estimates : $T(\text{PMF})$ lies between 10^7 and 10^9 years. A similar comparison on 47 catchments in the world (see CFGB, 1994) gives the following results : $T(\text{PMF})$ lies between 10^4 and 10^7 years, and the ratio $\text{PMF}/Q_{\text{AGR}}(10\,000\text{ years})$ lies between 1 to 3.

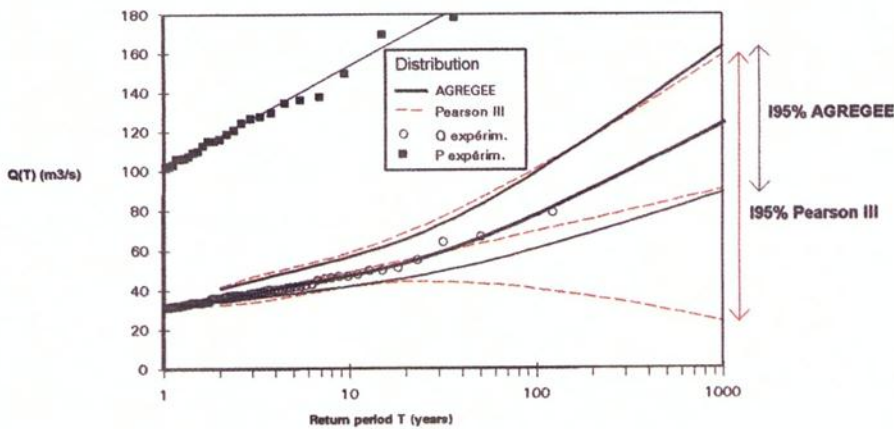

Figure 6 : Confidence interval of flood quantiles, with or without rainfall information

Figure 6 : Intervalle de confiance des quantiles de crue, avec ou sans information pluviométrique

So, it is very difficult to find operational conclusions to this comparison. The PMP/PMF method gives very large estimates, that seems to be dependant of the available data. Complementary work should be done with the use of a more complex PMP/PMF calculation.

5 Conclusions

Margoum (1992) developed a new statistical model AGREGEE, as an aggregation of sub-models. The initial aim was to generalise the GRADEX method, that makes extreme floods' prediction for safeguarding large dams, with rainfall information. The AGREGEE model is divided into three parts : the first one uses discharge information, the third one uses rainfall information, the second links the two preceding ones continuously.

Since the last four-year FRIEND Report, some developments allow the statistical treatment of the three parts of the AGREGEE model to be improved : a rigorous over-threshold sampling technique, a better situation for a validation through several methods (use of long historical discharge series, test of a more physically-based progressive option, comparison with other methods), and a calculation of the flood quantile confidence interval . Future work will concern the intercomparison with other frequency methods. One of the most interesting subjects will be the comparison between the AGREGEE method and the index flood method that uses regional flood information. Another important subject concerns the statistical behaviour of areal rainfalls.

Validation of synthetic tools by simulation

Validation de modèles de synthèse par simulations

S. Blazkova, K. Beven, S. Kolarova, M. Lang

1 Introduction

The AGREGEE approach was validated on a small catchment (26 km²) in the Jizera Mountains in Czech Republic using the frequency version of TOPMODEL within the GLUE framework. The series of 28000 flood peaks modelled without considering the uncertainty in parameters produces an estimate of the 10000 year flood close to the AGREGEE result obtained with one of the four variants tested. All AGREGEE estimates of the 1000 year flood fall within the confidence limits produced with the GLUE methodology, i.e. taking into account uncertainty in parameter values.

The comparison between the AGREGEE (Margoum, 1992) and GLUE frequency TOPMODEL approach has been carried out on the Josefuv Dul catchment (26 km²) in the Jizera Mountains, Czech Republic. Only flood peaks of the summer half year were taken into account, because for longer return periods only summer floods are important. There are data of the Czech Hydrometeorological Institute (CHMI) available : a series of daily discharges, a series of peaks for 68 years, a historical flood and 83 years of daily rainfalls containing a value of 345 mm (while the second largest daily total is only 160 mm).

In Fig.1 the AGREGEE peak flows are shown in four variants using various distributions for daily flows, for peak flows, for the ratio between peak flows and daily flows and the independence or dependence between the peak flows and the ratio.

TOPMODEL is a simple semi-distributed model based on an assumption that the effective hydraulic gradient at a point can be approximated by the local slope angle. The effects of topography and soil information are represented in the form of the distribution of the soil-topographic index ($a/T_0 \tan \beta$) where a is the area drained per unit contour length at a given point; β is the slope angle, and T_0 is the lateral transmissivity when the soil is just saturated (m²/h). TOPMODEL in its various versions and modifications is described in detail in Beven et al. (1995).

In the frequency version the input to TOPMODEL is rainfall in hourly time steps produced by a rainfall simulator. It has two types of storms : with high intensity and with low intensity. The durations, intensities and interarrival times have exponential distributions. The result of the frequency version is a series of annual flood peaks of a considerable length. In Fig. 1a is an example of a series of 28000 years (Blazkova and Beven, 1997). There is a great advantage in modelling a long time series because the estimates of rare floods can be read easily in the picture without fitting any distribution (see the region up to about $ev1=6.2$, i.e. 500 years return period). The scatter of points shifts to higher return periods as a longer series is modelled.

AGREGEE models higher flood peaks in the observable and rare floods domain, but in the region of extreme floods the peaks modelled with TOPMODEL are very close to the lowest variant of AGREGEE (Fig. 1a).

The TOPMODEL curve (composed of modelled points) is more curved than AGREGEE distributions. The curvature is governed by both the dynamics of rainfall and the dynamics of the catchment saturation. It was found during extensive field observations that TOPMODEL is an adequate description of the functioning of the catchment.

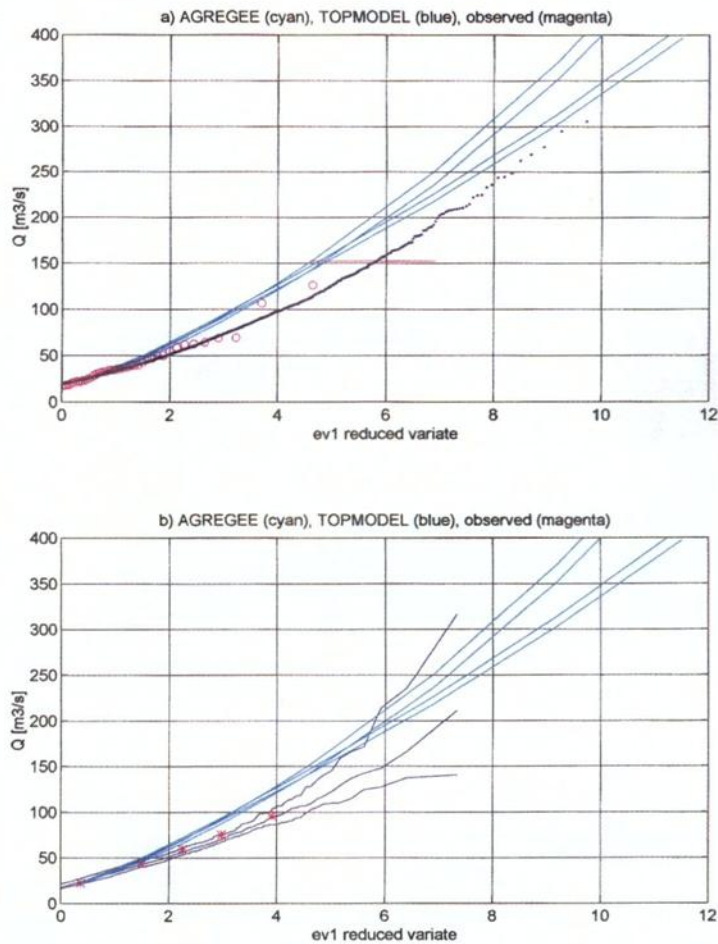

Figure 1 - AGREGEE and TOPMODEL

- AGREGEE results (cyan) computed in following variants which differ by distributions of Q (daily flows), Q_i (peak flows), R_i (ratio of Q and Q_i) and by independence or feeble dependence of Q_i and R_i in a) and b) from the lowest to the highest curve

Q - exponential mixture, Q_i - Gumbel, R_i - Gumbel, independence of Q_i and R_i

Q - exponential mixture, Q_i - Gumbel, R_i - Gumbel, feeble dependence of Q_i and R_i

Q - exponential mixture, Q_i - exponential mixture, R_i - exponential, independence of Q_i and R_i

Q - exponential mixture, Q_i - exponential mixture, R_i - exponential, feeble dependence of Q_i and R_i

- TOPMODEL results (blue)

a) 28000 peaks modelled with most parameters computed from data and calibrated transmissivity parameters

b) median and 90% confidence limits computed from modelled series of the length 1000 years by GLUE (taking into account uncertainty in parameters)

- Observed data (magenta)

c) observed summer half year peaks of CHMI (circles), historical flood (horizontal line between return period of 100 and 1000 years)

d) quantiles of Wakeby distribution fitted to observed data up to 50 years return period (values used for rejecting of non-behavioural simulations)

ev1 is extreme value 1 (Gumbel) reduced variate (50 years: return period ev1=3.9, 100: ev1=4.6, 500: ev1=6.2, 1000: ev1=6.9, 10000: ev1=9.2, 100000: ev1=11.5)

Figure 1 : Comparaison AGREGEE (bleu cyan), TOP MODEL (bleu) et valeurs observées (rouge magenta)

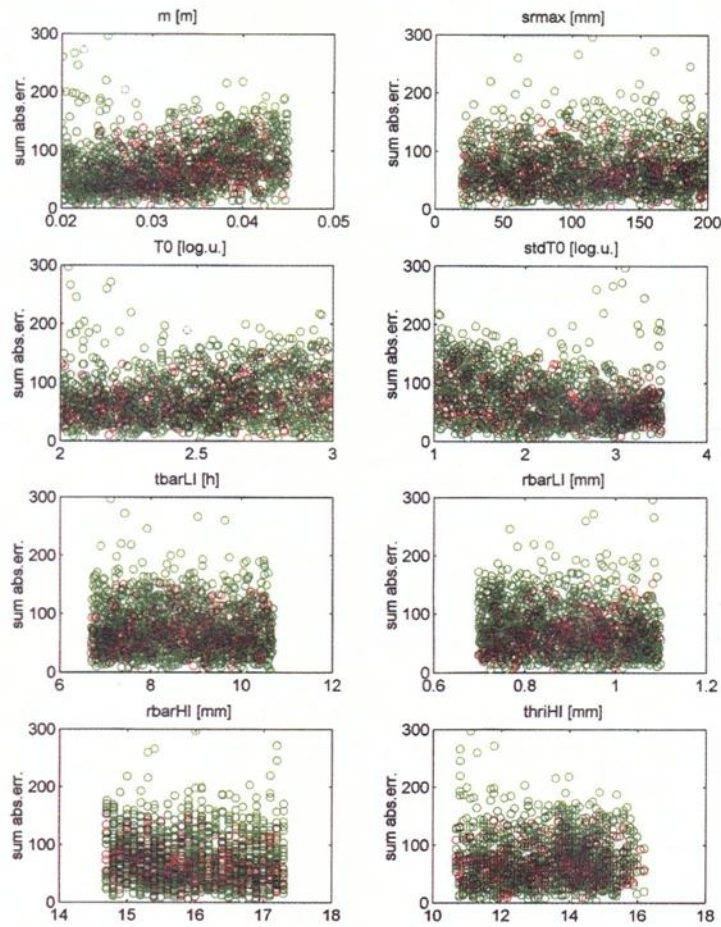

Figure 2 : GLUE plots of individual parameter values versus the criterion of efficiency (sum of absolute errors between the individual realizations and Wakeby distributions fitted on observed data) from 68 years simulations.

Parameters: recession parameter m ; root zone parameter $srmax$; two parameters of the transmissivity distribution, i.e. mean value $T0$ and the standard deviation $stdT0$; mean duration and mean intensity of low intensity storms $tbarLI$ and $rbarLI$, respectively; mean intensity of high intensity storms $rbarHI$ and threshold on the high intensity storms $thriHI$. Green circles - non-behavioural simulations, red circles - behavioural simulations (remaining after constraining).

Figure 2 : Simulations de GLUE issues des calages sur 68 ans sans (a) et avec (b) contraintes sur les conditions initiales (transmissivité réaliste).

In the TOPMODEL frequency curve in Fig. 1a, however, no uncertainty in parameters is considered. A formal framework for taking the uncertainty into account is provided by the GLUE procedure (Generalized Likelihood Uncertainty Estimation, Beven, 1993). It incorporates the possibility that different sets of parameter values may be equally likely as simulators of a catchment system within the limitations of a given specific model structure and errors in the observed variables. GLUE has been applied in connection with various models by Beven and Binley (1992), Beven (1993), Romanowicz et al. (1994), Freer et al. (1995), Fisher and Beven (1994).

A GLUE frequency version of TOPMODEL is described in Blazkova and Beven (1996). The values of four TOPMODEL parameters and four rainfall simulator parameters are sampled from uniform distributions (Fig.2).

Many sets of parameters are created and with each of them a TOPMODEL frequency computation is carried out. The modelled series are then fitted to the Wakeby distribution using L-moments (programs of Hosking, 1991). Besides the quantiles of the Wakeby distribution and all modelled annual peaks, information on modelled low flows and precipitation are also stored for checking if the modelled series is realistic.

Since there is a 68 years series of observed summer half year flood peaks available, it can be expected that the flood frequency curve is reasonably accurate up to a 50 year return period. The modelled frequency curves fitted by Wakeby distribution were compared to the Wakeby distribution fitted to the observed values using the sum of absolute errors at seven quantiles (for probabilities from $p=.1$ to $.98$) as a criterion.

Because of computational constraints the simulation was carried out in two steps. First estimates of the same length as the observed series were modelled; the total number of estimates was 1379. The scatter plots of all the simulations are in Fig.2. Good simulations from the point of view of the criterion (sum of absolute errors) occur throughout the whole range of all the parameters which confirms the GLUE assumption that it is the set of parameters which is important. None of the parameters is showing any optimum. This finding differs from other GLUE applications where usually at least the m parameter was sensitive.

The TOPMODEL parameters (especially m and transmissivity) in various combinations produce different durations of low flows under a specified quantile. The low flow regime creates the initial conditions for floods and therefore it is important to keep the right fraction. The fraction computed from the observed data was 0.24. A constraint was imposed so that estimates with a lower fraction than 0.22 and higher than 0.26 are rejected. The second constraint is a realistic relation between the rainfall high intensity parameters $rbarHI$ and $thriHI$.

It is worthwhile to note that after constraining many simulations with a good value of the criterion (low sum of absolute errors) were rejected (Fig. 2).

In Fig.3 the frequency curves of all the simulations (Fig.3a) and the simulations which remained after constraining and after rejecting those with the sum of absolute errors larger than $50 \text{ m}^3/\text{s}$ (Fig. 3b) are shown, respectively.

Due to the short length of the series the range of fitted distribution is very large. Moreover, there is the same problem as with fitting a distribution to observed data. In the region of long return periods the fitted curve can go to very large values, much larger than any of the modelled peaks.

As a second step estimates of 1000 years were computed using the 100 best parameter sets selected from the 1379 runs above; the selection was based on conditioning on low flows and the relation of the high intensity parameters and on ranking the estimates according to the sum of absolute errors as described above. In Fig. 4a all the estimates and in Fig. 4b the estimates remaining after constraining are shown, respectively - this time as modelled points without using any distribution. It has the disadvantage that they go only to the 1000 years return period. The confidence limits computed from the 20 best of them are in Fig. 1b.

It can be seen (Fig.1b) that in the region roughly from 100 and 1000 years return period all the AGREGEE simulations are within the 90% uncertainty bounds computed from modelled GLUE - TOPMODEL points.

The TOPMODEL bounds are very narrow in the observable domain which is probably caused by the two step constraining and rejecting procedure. In another application, where only 100 of 1000 years series were modelled, the bounds were wider.

There is an obvious need to use larger computing power to be able to model longer series within the GLUE framework and also to produce more parameter sets.

Using a realistic hydrological model together with a suitable set of physically based constraints can help in the precarious task of extrapolation of floods into the extreme domain.

Acknowledgement

The work presented here was funded by the Ministry of Environment of Czech Republic within the project 043, grant PPZP/510/7/96 and by the European Union within the contract ERB-CIPD-CT94-0114. The data from the Jizera Mountains were provided by the Czech Hydrometeorological Institute.

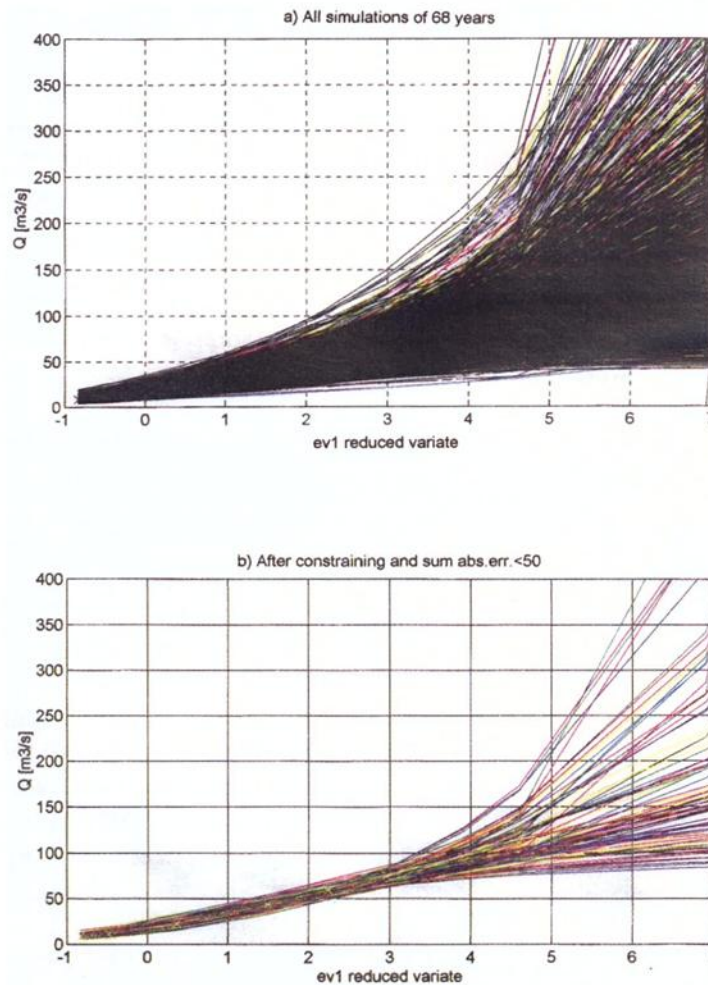

Figure 3 : a) Flood frequency curves of all 68 years simulations fitted by Wakeby distribution;
 b) Flood frequency curves of those 68 years simulations remaining after constraining and rejecting those with sum of absolute errors larger than $50 m^3/s$.

ev1 is extreme value 1 (Gumbel) reduced variate (50 years: return period $ev1=3.9$, 100: $ev1=4.6$, 500: $ev1=6.2$, 1000: $ev1=6.9$, 10000: $ev1=9.2$, 100000: $ev1=11.5$)

Figure 3 : Simulations retenues, sans (a) et avec (b) contraintes supplémentaires sur les erreurs ($< 50 m^3/s$)

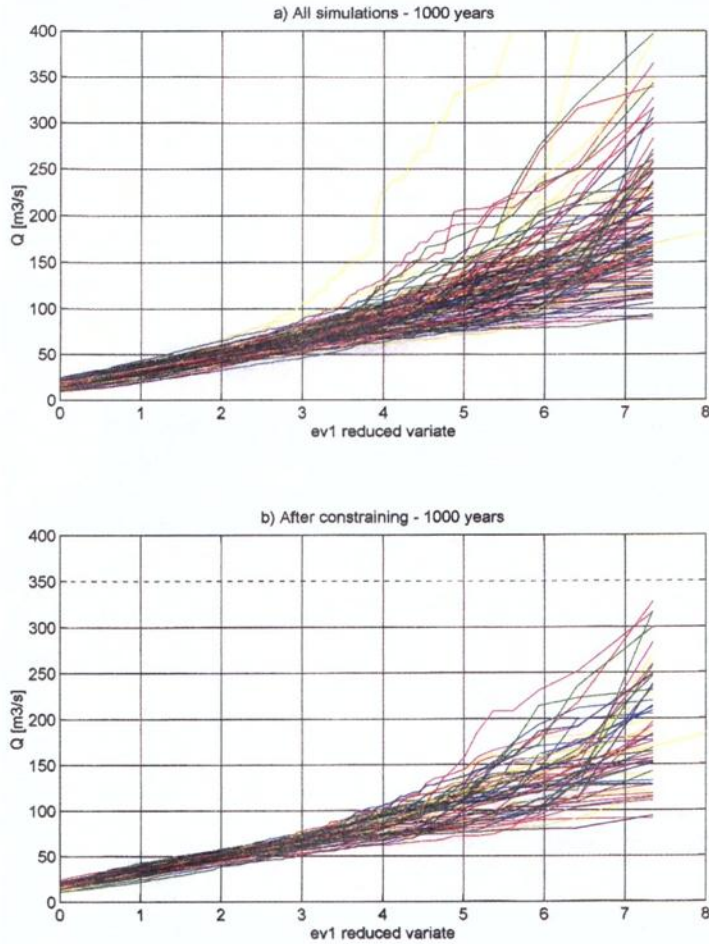

Figure 4 : a) Flood frequency curves of all 1000 years simulations as modelled peaks;
 b) Flood frequency curves of those 1000 years simulations remaining after constraining $ev1$ is extreme value 1 (Gumbel) reduced variate (50 years: return period $ev1=3.9$, 100: $ev1=4.6$, 500: $ev1=6.2$, 1000: $ev1=6.9$, 10000: $ev1=9.2$, 100000: $ev1=11.5$)
Figure 4 : Distribution sur les pointes, avant (a) et avec (b) contraintes

Comparative study of flood characteristics in Southern Africa

Étude comparative des caractéristiques de crues en Afrique Australe

S. Mkhandi

1 Introduction

This report summarizes in brief the results of the analysis of flood statistics and frequency growth curves derived for the countries of South Africa. This study was carried out as part of the Southern Africa FRIEND research sub-project on flood frequency analysis. The study area consists of 11 countries. The countries are Angola, Botswana, Lesotho, Malawi, Mozambique, Namibia, South Africa, Swaziland, Tanzania, Zambia and Zimbabwe. All the countries lie south of the Equator to about 35° South.

2 Data

Data from a total of 754 gauging stations with average record length of 24 years from eleven countries in Southern Africa was used as the basis for carrying out this study. Annual maximum instantaneous discharge series were used in the study. However, for those countries where annual maximum instantaneous flows were not available, annual maximum mean daily discharge series were used. The data used in the study was contributed to the Southern Africa FRIEND data base by the participating countries. This data base is currently situated at the University of Dar es Salaam, Tanzania. Information on the number of sites, their corresponding record lengths, and the type of flood data that were available for the study is presented in Table 1.

Table 1 : Summarized information on available flood data for the study

Table 1 : Informations succinctes sur les données de crues exploitables

Country	Area (km ²)	No. of sites	Record length	Status of data
Angola	1,246,700	17	6	Mmax.
Botswana	581,730	14	16	Inst.
Lesotho	30,355	23	9	Inst.
Malawi	118,484	28	18	Inst.
Mozambique	799,380	16	25	Mmax.
Namibia	823,145	51	19	Inst.
S. Africa	1,221,037	316	32	Inst.
Swaziland	17,364	33	14	Inst.
Tanzania	945,087	146	17	Ext.
Zambia	752,614	24	22	Mmax.
Zimbabwe	390,580	86	21	Inst.
Total		754		

NB: Mmax = Maximum mean daily discharge

Inst = Maximum Instantaneous discharge

Ext = Extended maximum instantaneous discharge

3 Variability and skewness of flood flows

Table 2 presents average flood statistics computed from stations that were used for detailed analysis. It may be observed that the average coefficient of variation (cv) values for Botswana, Mozambique, Namibia, South Africa and Zimbabwe are close to 1.0. The coefficient of variation provides a useful measure of hydrological variability. It indicates that the distribution of floods in these countries is highly variable. The cv values determined for Malawi, Lesotho and Swaziland are very similar (about 0.66). The cv values for Angola, Tanzania and Zambia are slightly lower compared to other countries, i.e, 0.56, 0.50 and 0.44 respectively. The different levels of variability in the observed flood samples may be attributed to varying hydrological phenomena responsible for generating the flood events over the different countries.

Table 2 : Average flood statistics for the 11 countries in Southern Africa.

Table 2 : Paramètres moyens de crues pour 11 pays d'Afrique Australe

Country	Sites	No. Yrs	Cv	Cs
Angola	15	6	0.56 (1)	1.66
			0.15 (2)	1.41
Botswana	11	15	0.97	2.65
			0.19	1.36
Lesotho	13	9	0.67	1.94
			0.18	1.36
Malawi	25	17	0.66	1.46
			0.19	1.21
Mozambique	16	25	0.98	2.14
			0.45	1.51
Namibia	28	19	1.08	2.40
			0.44	1.37
S. Africa	141	33	1.00	2.32
			0.35	1.20
Swaziland	11	14	0.66	1.80
			0.16	1.01
Tanzania	77	15	0.50	0.92
			0.22	1.52
Zambia	17	20	0.44	0.89
			0.22	1.03
Zimbabwe	42	22	1.02	2.12
			0.37	1.41

From Table 2 it can also be observed that average values of skewness for Malawi, Tanzania and Zambia range between 0.9 to 1.5. The corresponding values for Angola, Lesotho and Swaziland are 1.5 to 2.0, and for Botswana, Mozambique, Namibia, South Africa and Zimbabwe the values range from 2.0 to 3.0. The range of skewness values observed in Southern Africa indicate that the distribution of flood flows from the region are positively skewed.

4 Derivation of frequency curves

From the results obtained from the predictive ability tests, P3/PWM and LP3/MOM were selected as robust flood estimation procedures for the hydrological regions in Southern Africa when considering bias as the test indicator. In this regard The P3/PWM was used to derive frequency growth curves for Angola, Botswana, Malawi, Mozambique, Namibia, South Africa, Swaziland and Zimbabwe. The LP3/MOM was used to derive the frequency curves for Tanzania and Zambia. Fig. 1 shows frequency curves derived for the eleven countries in Southern Africa (Angola, Botswana, Lesotho, Malawi, Mozambique, Namibia, South Africa, Swaziland, Tanzania, Zambia and Zimbabwe).

The investigation on the slopes of the derived frequency curves for the different countries indicate that the extent of the slopes seem to be governed by the variability of the flood regimes. For instance if the coefficient of variation (C_v) of flood flows for a given region is high the frequency curve for that particular region should be expected to be steep and vice versa.

The extent of the variability of the flood regimes depend to a larger extent on the meteorological phenomena generating the flood events. For example, Cunnane (1989) mentions that low C_v (0.1-0.2) values occur in equatorial regimes of high rainfall whose flood producing mechanism is fairly uniform from year to year and also in relatively impermeable, high rainfall catchments in temperate zones, while high C_v (greater than 1.0) occur in a region which display a well-behaved heterogeneity or in a case where there is presence of one or more outliers in the data. Arid zones also are often characterised by very high values of C_v because floods in arid zones arise mainly from intense convective thunderstorms of very limited areal extent and therefore affect catchments randomly with little spatial pattern and coherence. Minor floods also do occur as a result of other lower intensity rainfalls.

The facts mentioned above may be used to explain the characteristics of the frequency curves presented in Fig. 1. For example, the steep slopes for Botswana ($C_v=0.97$) and Namibia ($C_v=1.08$) being semi-arid countries may be explained by the relatively high variability in rainfall producing the flood events. In the case of Mozambique ($C_v=0.98$), South Africa ($C_v=1.00$) and Zimbabwe ($C_v=1.02$) the steep frequency curve may be explained by the heterogeneity in the flood data used in the analysis. The pooling together of the flood data for these countries must have resulted in having a heterogeneous region. The tropical climate and the large catchment areas are the most likely factors which have resulted in obtaining gentle frequency curves for Angola ($C_v=0.56$), Tanzania ($C_v=0.50$) and Zambia ($C_v=0.44$). The frequency curves for Malawi, Lesotho and Swaziland are also observed to be relatively gentle. The characteristics of the different frequency curves therefore may possibly be described by first analysing the general hydrology of the region concerned.

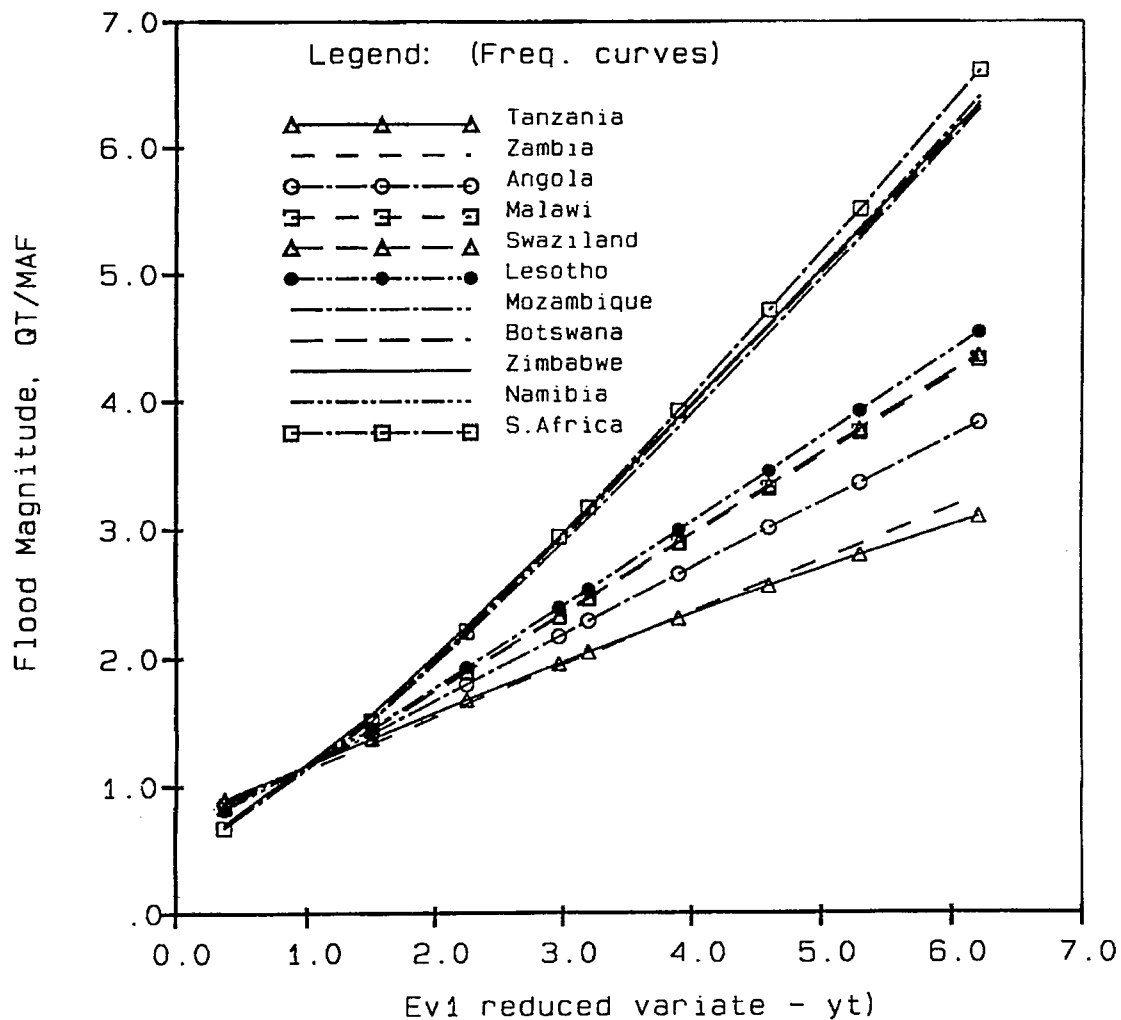

Figure 1 : Comparison of regional flood frequency curves
Figure 1 : Comparaison entre distributions de crues régionales

5 Conclusion

Based on the analysis of flood flows from 11 countries in Southern Africa average flood statistics and frequency growth curves were determined. The results obtained for the different countries were compared. The main conclusion is that the difference in the flood statistics and frequency growth curves were noted between countries. This shows that the meteorological phenomena generating the flood events in the different countries are different.

Regional hierarchical approach to flood frequency analysis

Etude de la distribution des crues par une approche hiérarchique régionale

P. Versace and E. Ferrari

1 Introduction

Usually flood frequency analysis copes with the flood quantile estimation related to a return period much greater than the observation period of the historical data. Regional flood frequency analysis (RFFA) overcomes this deficiency by increasing the amount of data involved by means of the use of all the gauging sites in the region of interest. RFFA explores the spatial links of hydrological variables, providing at-site/regional or purely regional flood quantile estimates which can be more precise than at-site estimates, even in the presence of moderate heterogeneity.

In the last decades, since the Flood Studies Report (NERC, 1975), many procedures of RFFA have been proposed, as reviewed, among others, by Potter (1987) and Cunnane (1987; 1988). The procedures differ by many features, as they combine in different ways at-site and regional information or use different kinds of data (annual maximum flood peaks series, peaks over a threshold series). Moreover some RFFA methods consider both rainfall and flood data, in order to transfer information from the former to the latter within appropriate homogeneous regions.

Two parameter distributions are often adopted. Such distributions lead to quantile estimates with relatively short standard error but large bias. On the other hand, distributions characterized by three or more parameters have larger standard errors but are sufficiently flexible to be relatively unbiased, especially in the case of homogeneous regions and mildly heterogeneous regions. In any case the use of these distributions within a regional scheme improves quantile estimations.

In the following paragraphs some RFFA for gauged and ungauged sites are briefly discussed, with particular attention to the hierarchical regional approach.

2 Regional flood frequency estimation at gauged sites

In a given geographical region let $X_{i,j}$ ($i=1,2,\dots,N_j$, $j=1,2,\dots,M$) be the annual maximum flood peaks series at M gauging sites, with a total of $L = \sum_1^M N_j$ years of records for all sites. When a design flood estimate is required at a gauged site where a long data series has been observed, normally the chosen flood distribution is fitted to the empirical distribution of the at-site series. In the case of series with few data, it is better to assume a regional estimation procedure, employing all the L station year data. This can be done if the hypothesis of homogeneous region holds, i.e. the hydrological behaviour of the basins within the region is similar. Many problems arise dealing with hydrological similarity in RFFA (Rossi and Villani, 1992a; Reed, 1992). The criterion of data pooling, the kind of region boundary (fixed or variable), the sharp differences across the boundaries, the standardization of data from different sites, the interstation correlation of the flood data are the main problems.

A geographical pooling of data is generally accepted assuming that, at least for higher moments, the rainfall regime is more important than geological, land use and catchment size effects. The latter prevail for location parameters, i.e. for lower moments. To avoid edge effects around the boundary lines of geographical regions, some authors adopt weighting schemes to identify the set of gauged sites to be gathered (Acreman and Wiltshire, 1989; Burn, 1988; 1990), even if the resulting regions may lose geographical meaning. A modified approach, more frequently used for rainfall frequency analysis (Reed, 1992), consists of flexible regions, centred on the subject site, whose extension directly reflects the return period of the design flood.

As regards the standardization of data, when it takes the simple form X/X_{index} , it is referred to as index flood method, first introduced in the USA by the Geological Survey (Dalrymple, 1960). Usually the index flood is the mean annual flood μ_X , whose sample estimate is denoted by \bar{X} . The dimensionless flood variate becomes $X' = X/\mu_X$, referred to as growth factor. If $E[X']$, $\gamma_{X'}$, $\gamma_{1X'}$ denote respectively expected value, coefficient of variation and coefficient of skewness of X' , the following properties hold:

$$E[X'] = 1 \qquad \gamma_{X'} = \gamma_X \qquad \gamma_{1X'} = \gamma_{1X} \qquad (1)$$

being γ_X and γ_{1X} the coefficient of variation and the coefficient of skewness of X .

The index flood method is characterized by two steps. The first step consists in determining the growth curve, i.e. the theoretical cumulative distribution function (CDF) of the growth factor. It is usually derived by considering all the hydrological information available in the homogeneous region. It can be done by assuming that the parameters of X' distribution remain constant in the region or change with regular trends from one site to another. The second step is the estimation of the index flood, \bar{X} , that can be carried out from at-site data or through regional relationships (NERC, 1975). The estimation of the design flood x_T is thus obtained as $x_T' \bar{X}$.

In many cases the station-year method is adopted, which consists in gathering together the standardized data to form a long random sample. This approach ignores the interstation correlation thus providing some bias at larger return period.

The scale invariance properties of floods have been explored by Gupta et al. (1994). With this approach the flood quantiles of two basins can be related, giving for the T-year flood of a basin of drainage area A the relationship $X_T(A) = g(A) X_T(1)$, where $g(A)$ is a function of A and $X_T(1)$ is related to unit area basin. This result shows statistical self-similarity, thus allowing new trends to assess the concept of hydrological homogeneity.

3 Regional models

3.1 The choice of flood distribution

The basic steps of RFFA are the choice of the flood distribution and the development of its regional structure. The parent distribution for flood must be chosen according to some basic criteria: the physical nature of the phenomena must suggest the model structure to use (theoretical basis), the flood distribution must be able to reproduce the statistical characteristics of the annual flood series (descriptive ability; Cunnane, 1987), the T-year flood estimate must have good statistical properties (predictive ability). Among the distributions able to satisfy these criteria there are the extreme value distributions obtained from Gumbel law (EV1 distribution), through power (PEV distribution) or logarithmic transformation (GEV distribution), and from mixture of flood processes which come from different physical mechanisms (e.g. TCEV distribution). In the following, TCEV and GEV models, whose hierarchical regionalization procedures have many common characteristics, will be analysed.

3.2 TCEV model

The TCEV model (Rossi and Versace, 1982) has proved capable of reproducing the statistical characteristics of a large number of observed European annual flood series, sometimes characterized by extraordinary extreme events. A regional version exhibits good statistical efficiency and robustness compared to various flood probabilistic models, as proved by Montecarlo experiments (Rossi et al., 1984; Fiorentino et al., 1987a; 1987b; Versace et al., 1989; Gabriele and Arnell, 1991; Gabriele and Iiritano, 1996). The model assumes that annual floods derive from a mixture of an

ordinary exponential component (frequent normal events, label 1) and an extraordinary one (rare severe events, label 2). The CDF is (Rossi et al., 1984) :

$$F_X(x) = \exp[-\Lambda_1 \exp(-x/\theta_1) - \Lambda_2 \exp(-x/\theta_2)] \quad (2)$$

The four parameters have simple physical meaning: Λ_i is the mean annual number of events, and θ_i is the mean annual value of events. Using the maximum likelihood (ML) method the four parameters can be estimated from at-site flood data series but this estimate exhibits very large variance. This uncertainty can be reduced by using a regionalization framework, making reference to the standardized variate Y:

$$Y = \frac{X}{\theta_1} - \ln \Lambda_1 \quad (3)$$

whose CDF is still of TCEV type and has the form:

$$F_Y(y) = \exp[-\exp(-y) - \Lambda_* \exp(-y/\theta_*)] \quad (4)$$

depending on the dimensionless parameters $\theta_* = \theta_2/\theta_1$ and $\Lambda_* = \Lambda_2/\Lambda_1^{1/\theta_*}$.

The regional growth curve is dependent only on Λ_* , θ_* and Λ_1 (Versace et al., 1989):

$$F_{X'}(x') = \exp[-\Lambda_1 \exp(-\eta x') - \Lambda_* \Lambda_1^{1/\theta_*} \exp(-\eta x'/\theta_*)] \quad (5)$$

with:

$$\eta = \frac{\mu}{\theta_1} = \gamma_\epsilon + \ln \Lambda_1 - \sum_{j=1}^{\infty} \frac{(-1)^j \Lambda_*^j}{j!} \Gamma\left(\frac{j}{\theta_*}\right) \quad (6)$$

where $\gamma_\epsilon = 0.5772$ is the Euler constant and $\Gamma(\)$ is the gamma function.

3.3 GEV model

The CDF of the General Extreme Value (GEV) distribution is (Jenkinson, 1955; NERC, 1975):

$$F_X(x) = \exp\left\{-\left[1 - k(x - u)/a\right]^{1/k}\right\} \quad (7)$$

This probability function assumes three different behaviours according to the value of its shape parameter k. When k equals 0 the GEV becomes a Gumbel law (EV1). For k<0 the GEV corresponds to Fréchet law (EV2), when k>0 the GEV is upper bounded (EV3). The standardized variate $Y = (X - u)/a$ is still of GEV type and its CDF has the form:

$$F_Y(y) = \exp\left[-(1 - ky)^{1/k}\right] \quad (8)$$

which depends only on the parameter k.

The regional growth curve, given by:

$$F_{X'}(x') = \exp\left\{-\Lambda_0 \left[(1 - x') + \frac{\Gamma(1+k)}{\Lambda_0^k} \right]\right\} \quad (9)$$

depends on both the shape parameter k and the scale parameter Λ_0 (i.e. the mean annual number of independent flood events with threshold zero) that is equal to:

$$\Lambda_0 = \left(1 + k \frac{u}{a}\right)^{1/k} \quad (10)$$

4 The hierarchical estimation procedure

The exchange of regional information from one site to another is affected in different ways by time sampling variance, space disturbance variance and interstation correlation. As the order of the moments of the statistics involved increases, sampling variability increases too but space disturbance variance among the sites decreases and interstation correlation becomes more negligible.

This behaviour suggests a modified form of the index flood method. Instead of using two levels of analysis, dealing with growth factor and index flood, regional analysis can be hierarchically framed into three distinct levels. From a spatial point of view, a homogeneous region with respect to the skewness coefficient is first identified, wherein the sampling skewness of the observed annual flood series, G , generally shows a spatial variance observed among the sites not greater than its at-site sampling variance. Within this region more homogeneous subregions can be identified according to the behaviour of the coefficient of variation, C_v , which also shows a spatial variance not greater than at-site sampling variance but on a smaller spatial scale. Finally on a basin scale, homogeneous areas are identified where it is possible to explain the variability of index flood, i.e. of the mean.

The theoretical values of these moments depend on the parameters of the flood distribution. Particularly the first level of this procedure involves the estimation of the shape parameters of the model, the second involves the scale parameters and the third the location parameters. This approach, referred to as hierarchical, optimizes the exploitation of regional information.

A comprehensive hierarchical estimation procedure has been built using the TCEV model (Fiorentino et al., 1987a). For this model the theoretical skewness coefficient γ_1 only depends on its shape parameters, θ_* and Λ_* . So the regional hypothesis θ_* and $\Lambda_* = \text{const.}$ is equal to assume $\gamma_1 = \text{const.}$ in the region. This implies that the Y variate is identically distributed over the whole region with CDF (4). Similar results can be obtained by the analysis of the L-skewness τ_3 (Hosking, 1990), expressed as follows:

$$\tau_3 = 2 \frac{3\beta_2 - \beta_0}{2\beta_1 - \beta_0} - 3 \quad (11)$$

where β_r is the r^{th} non central probability weighted moment (PWM, Greenwood et al., 1979). In fact since also L-skewness depends only on the shape parameters, the constancy of θ_* and Λ_* implies the constancy of τ_3 . At the second level of regional analysis, the scale parameter of TCEV distribution is Λ_1 . The theoretical coefficient of variation γ depends on Λ_* , θ_* , Λ_1 . So if Λ_1 is assumed to be constant inside a part (subregion) of an homogenous region with Λ_* and θ_* constant, γ will also be constant. In a subregion the standardized variate X' is identically distributed, according to the CDF (5). In a similar way, the L-moment ratio τ_2 :

$$\tau_2 = \frac{2\beta_1 - \beta_0}{\beta_0} \quad (12)$$

that depends on the parameters θ_* , Λ_* and Λ_1 , is also constant in a subregion.

As regards a hierarchical regional version of GEV model, a homogeneous region exhibits a constant value of parameter k . So the standardized variate Y is identically distributed with CDF expressed by the (8). Owing to dependence on k of both the skewness coefficient γ_1 and L-skewness τ_3 , in homogeneous regions γ_1 and τ_3 are constant too.

At the second level of regional analysis, dealing with homogenous subregions Λ_0 is also constant. Then X' is identically distributed according to (9), coefficient of variation γ and L-moment ratio τ_2 are both constant.

Within the framework of the hierarchical procedure, pluviometric information may be very useful when flood information is very poor. This is particularly true for the TCEV model which exhibits, at the second level of regional analysis, a strong relationship between the mean annual number of independent flood events and of independent rainfall events (Rossi and Villani, 1992a). These mean

values are both described by the parameters Λ_1 of the TCEV distribution. Moreover many regions and subregions give homogeneous results for both rainfall and flood analysis.

The TCEV hierarchical model

The hierarchical procedure based on TCEV distribution is described here in more details. The analysis also concerns the extreme rainfalls in order to identify homogeneous regions and subregions. The procedure is formed by the following steps:

Daily rainfall analysis

The first level of regional analysis carries out:

- a) analysis of the spatial trend of sampling skewness coefficient;
- b) preliminary hypothesis about the geographical extension of the homogeneous region;
- c) regional estimation of shape parameters θ_* and Λ_* through the maximum likelihood method whose equations are solved by an iterative numerical scheme (Fiorentino et al., 1987a; 1987b);
- d) check of hypothesis b) by comparing the observed frequencies of sampling skewness coefficients, G , obtained from the annual daily rainfall series involved within the region, and the CDF of the synthetic skewness coefficients, obtained by Montecarlo random generations (Versace et al., 1989);
- e) change of first hypothesis, assuming two or more homogeneous regions, if necessary;
- f) repetition of the steps c),d) and possibly e).

At a second level of regional analysis, the goal is the identification of pluviometric homogeneous subregions. The procedure is like the previous one:

- a') analysis of the spatial trend of sampling variation coefficient;
- b') preliminary hypothesis about the geographical extension of the subregions;
- c') regional estimation of scale parameter Λ_1 through the maximum likelihood method whose equations are solved by iterative numerical scheme;
- d') check of hypothesis b') comparing the observed frequencies of sampling variation coefficients, C_v , obtained from the observed annual daily rainfall series involved within the subregion and the CDF of the synthetic variation coefficient, obtained by Montecarlo random generations;
- e') change of first hypothesis, assuming each region is subdivided into two or more homogeneous subregions, if necessary;
- f') repetition of the steps c'), d') and possibly e').

At the third level of regional analysis the index rainfall is evaluated. At gauged sites it can be easily done by assuming the sampling mean as index rainfall. At ungauged sites the evaluation can be done through empirical relationships which relate the mean and the geographical parameters (e.g. elevation, distance from sea, etc.) of the neighbouring gauging stations.

Flood analysis

At the first two levels the regional analysis for floods is the same as for rainfalls. The main problem could be the lack of flood data owing to the small number of runoff gauging stations with large historical series. Therefore, as a first hypothesis at least, homogeneous regions and subregions for floods are assumed to coincide with pluviometric ones. Other hypotheses can be formulated and checked through clustering techniques applied to observed values of G and C_v . At the third level the mean observed value of annual flood series is estimated as the index flood at gauged sites. For ungauged sites the procedure is described below.

5 The case of ungauged sites: regionalization of the mean annual flood

At ungauged sites the index flood \bar{X} can be estimated using various approaches that are not dependent on the probabilistic model used for the regional procedure. Index flood \bar{X} can be obtained using empirical relationships with morphological and climatic characteristics of the basin, calibrated from the available neighbouring data sets. Such relationships usually have the form:

$$\bar{X} = c X_1^{a_1} X_2^{a_2} \dots \quad (13)$$

where X_1, X_2, \dots are catchment characteristics and c, a_1, a_2, \dots multiplicative and exponential coefficients. Nevertheless these formulae do not provide very reliable estimates (Hebson and Cunnane, 1987). Multiregressive analysis, as a particular case, includes the classical rational formula:

$$\bar{X} = C A \bar{I}_r \quad (14)$$

where C is a flood coefficient, A is the area of the basin and \bar{I}_r identifies the mean of annual maximum of rainfall rate of duration t_r , that is the basin lag time (Ferrari, 1994; Ferrari and Versace, 1995).

To take into account the actual phenomena causing runoff, a conceptual geomorphoclimatic model has been developed for index flood estimation, as a kind of modified rational formula (Rossi and Villani, 1988). The model considers as rainfall input constant rectangular pulses, according to depth-duration rainfall curve of the basin. The following expression is achieved:

$$\bar{X} = C_f q A \bar{I}_r \quad (15)$$

where C_f is the runoff coefficient, q is the adjusted peak attenuation coefficient which only depends on the exponent of the intensity duration rainfall curve (Ferrari et al., 1990).

6 A case study

A special study concerning the standard evaluation of extreme floods, called the VAPI project, was promoted in Italy in the '80 by the Italian National Group for the Prevention of Hydrogeological Disasters, belonging to the National Research Council (Ferrari and Versace, 1995). The applications of the VAPI project to the Italian regions, obtained with a complete statistical analysis of both rainfall and flood data, was first edited as regional reports (e.g. Versace et al., 1989), whose aim was to give standard procedures to estimate the extreme flood with assigned return period within a defined geographical area. A draft version of the synthesis of the VAPI project was recently edited (Versace, 1994).

The project, based on a regionalized framework of the TCEV distribution, can be seen as a modified version of the index flood method, hierarchically planned as cited in paragraph 4.

The first level of flood regionalization applied to the Italian rivers leads to a working hypothesis of subdivision of Italy (about 300,000 km²) into four hydrometric homogeneous regions. As an example of these regions a comprehensive regional flood analysis of the central and southern part of Italy (Fiorentino et al., 1987a) recognizes that the whole Apennine region and Sicily form a unique homogeneous region for floods. In this analysis 28 annual flood series were employed, observed in basins with an area smaller than 3000 km², giving a total of 1091 station years data. Nevertheless the identification of hydrometric homogeneous regions at the first level of regionalization in a country like Italy leaves some uncertainty, due to the spatial extension of the regions compared with the density of flood data.

At the second level of regionalization, as an example of the preliminary rainfall frequency analysis, behaviour analysis of the variation coefficient of the annual maxima of daily rainfalls of a region like Calabria (about 15,000 km²) leads to subdivision of the whole region into three rainfall homogeneous subregions. The same subdivision, verified through Montecarlo synthetic generations, has been recognized valid for flood homogeneous subregions too. Many regional reports also show that flood subregions often coincide with the pluviometric ones (Versace et al., 1989; Copertino and Fiorentino, 1991; Cao et al., 1991; Cannarozzo et al., 1993; Rossi and Villani, 1992b). The growth curve obtained for various Italian regions can be considered capable of giving regionally well-estimated growth factors (fig.1).

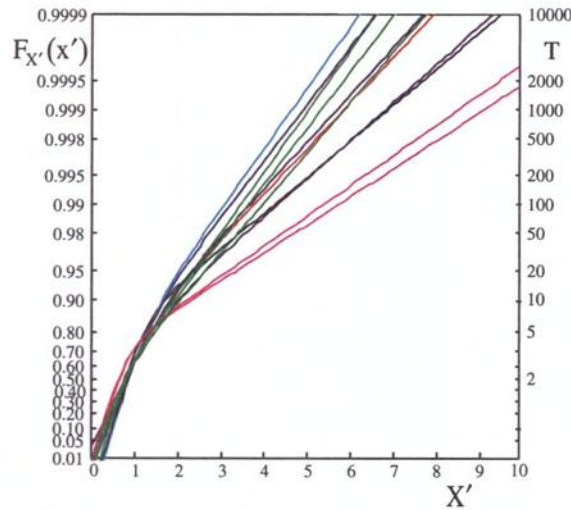

Figure 1 : Growth curve of floods for various Italian regions (___: North-western Italy; ___: Campania; ___: Puglia; ___: Calabria (west, central, east); ___: Sicily (west, east, south); ___: Sardinia (west, east))

Figure 1 : Distribution de crues pour diverses régions italiennes

Finally among all the different approaches quoted for index flood estimation, the regression between index flood and catchment characteristics and the rational formula were the most used methods in the regional VAPI reports. Besides these approaches, some regional reports have successfully used the geomorphoclimatic model and the scale invariance properties, to consider a more detailed representation of the flood phenomena on a basin scale. As an example, the relationships for some regions are presented in fig.2.

7 Conclusions

The RFFA is a useful scheme for a reliable estimation of the design flood, often providing more precise results than careful analysis of a limited number of data. It can relate the analysis means to the information that is actually necessary and that can be extracted from the data.

A good regional flood frequency model has to taken into account that passing from the regional spatial scale to the basin scale the available data diminish but it becomes more important to employ specific information about the hydrological behaviour of the basin.

In particular, the regional framework of the TCEV flood distribution can satisfy these opposite tendencies. The estimation procedure can be hierarchically subdivided into three levels of regional analysis, each level being capable of matching rainfall and flood information within large homogeneous areas. By means of two preliminary levels of analysis, the procedure combines hydrological data provided by many stations, drawing inferences only on highly variable statistics such as the coefficients of skewness and variation, for which only mean values can be estimated in large areas. At these levels TCEV regional procedure is a merely statistical analysis since the physical characteristics of the single basin do not have a direct influence on the statistics involved.

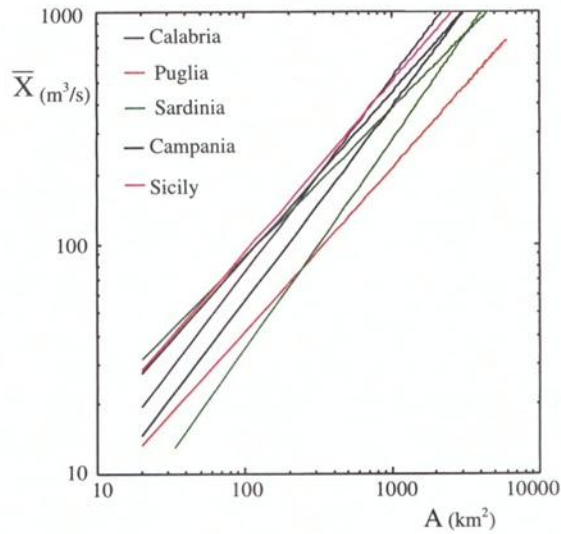

Figure 2: Empirical relationships between mean annual flood \bar{X} and basin area A for various Italian regions

Figure 2 : Relations empiriques entre crues annuelles moyennes et aires des bassins versants, pour diverses régions italiennes

At a third level of regional analysis, the approach changes : more specific data at a basin spatial scale on morphologic features and climatic behaviour are needed but there is less information available than before. Inference can be drawn only on the central values of the distribution, like the mean, more robust than the moments of greater order and strongly depending on the geographical features of the basin. At this level the information provided by the knowledge of the hydrological phenomena acting on the basin recovers significance. As for the estimation of the index flood, the RFFA can usefully employ empirical regression relationships or more refined physical modelling of the phenomena, even if involved in a schematic way. In such a regional approach statistical and deterministic methods become two complementary steps of the same comprehensive flood frequency analysis.

The SMFH/NIMH Synthetic Hydrographs Computing Methods

Les méthodes SMFH/NIMH de calcul des hydrogrammes synthétiques monofréquence

V. Oancea, G. Oberlin, R. Mic

1 Introduction

Despite the efforts to control the effects of floods by means of both structural and non-structural measures, there is a continuously increasing of the economic and social losses, due both, of the continuous developing of the urban areas, and of the inadequacy of the hydraulic solutions against flooding (often judged only to offer a local protection, without an integrated analysis at consequences at the basin scale).

In the present paper are presented the results of the analysis of the synthetic hydrographs computing methods, for Crisul Alb basin of western Romania (figure 1). Two methods have been used: Synthetic Mono-Frequency Hydrograph (SMFH), part of the INONDABILITE model (Cemagref, Lyon) and a Romanian hydrological service method (of National Institute of Meteorology and Hydrology, Bucharest), named in the following as "NIMH method".

Both methods suppose extrapolation of maximum discharges (based on specific on-site frequency analysis) for different duration, the construction of the synthetic hydrographs ("design flood hydrograph") for all the needed cross-sections (gauged and ungauged) of the hydraulic model of the basin, in order to identify the flooded areas and the risk assessment across the basin.

They also exhibit hydrologic regionalization techniques, in a specific form and at different levels of integration in the calculation of the synthetic hydrograph parameters of maximum runoff.

The INONDABILITE model is a complex and powerful tool that combines specific hydrologic, hydraulic and cartographic modules to analyze and describe the maximum runoff behavior at the basin scale. The NIMH method is a classical and robust approach of maximum runoff analysis, operational-oriented.

In the remaining of this paper the main results of the hydrologic analysis (the models AGREGEE, QdF and HSMF) of the INONDABILITE model, for the Crisul Alb basin, will be presented in comparison with the same results obtained by the NIMH method.

2 Data

Crisul Alb basin is located in the western part of Romania (figure 1) the analyzed area having a total surface of 2376 Km² and a mean altitude around 550 m. The climate is mild, a little bit more humid than the standard temperate continental climate, which is specific for Romania. In winter there is a, relatively, important snow depth cover on the surrounding hills, in the humid winters, and important rain depths in autumn. The flood regime is bi-annual with early spring and late autumn maximum values.

The sub-basin areas used in this study are among 14.3 and 2367 km², with mean altitudes among 450 and 750 m, in the basin being available 20 hydrometric, 23 pluviometric and 2 meteorological (synoptic) gauging stations (the hatched areas in figure 1). The analyzed data were : the annual maximum and the POT series of maximum discharges and precipitation intensities, continuously registered at the basin gauging stations. The length of the employed discharge series was among 23 and 46 years, and among 23 and 57 years for the precipitation values.

Actually two types of maximum precipitation and discharge series were used in the present study: the annual maximum instantaneous values and the peak over threshold sliding maximum averages over

different duration respectively (with specific types of event separation, for precipitation and maximum discharges respectively, to insure the random character of the selected values). No significant withdrawals, diversions or other regulating structures are contained in the analyzed sub-basins, hence the rivers were considered to be essentially unregulated.

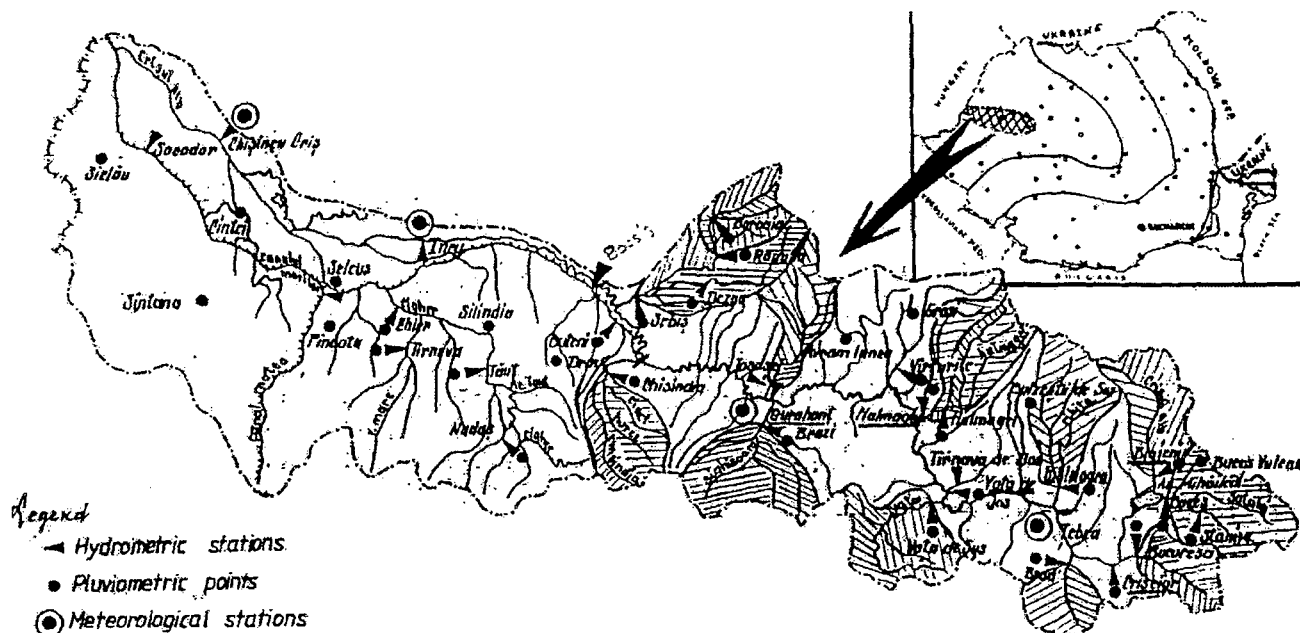

Figure 1 : Crisul Alb basin (the hatched area are the analysed sub-basins)

Figure 1 : Bassin du Crisul Alb (les aires hachurées concernent les sous-bassins analysés)

3 The INONDABILITE model

The hydrological integrated INONDABILITE model (Galéa 1989, Oberlin and Margoum 1991, Gilard and Oancea 1992) exploits, for the discharge extrapolation, a complex module, acronym AGREGEE. It combines statistical characteristics, of both precipitation and discharge series, with analytical and deterministic aspects of the maximum flood's behavior, and extrapolates the maximum discharges based, in an asymptotic manner, on the maximum precipitation probability distribution function shape.

Further on, a regional analysis and transfer of the discharge quantiles, previously computed by the AGREGEE model, is performed by a synthetic sub-model, acronym QdF, (from Q-discharges, d-duration and F-frequencies). It displays explicitly (for the duration d and the frequency F) or implicitly (for depth p and velocity V), the hydrological knowledge needed to quantify the social request towards the flood risk.

In a third step, a specialized module computes the synthetic mono-frequency hydrographs (acronym HSMF) for all analyzed section, the necessary entries of the basin hydraulic model.

3.1 The discharges extrapolation - the AGREGEE model

The AGREGEE model (Oberlin 1989, Margoum 1990) is based on the classic GRADEX model (Guillot and Duband 1967) from which it keeps the main hypothesis, respectively :

i. within the flood duration, when the water storage capacity of the basin is saturated, any dP increase of the precipitation depth, measured over an appropriate time step, generate a dQ increase of the runoff discharge, that tends to become equal with dP ;

ii. the probability distribution function of the precipitation series has an asymptotic exponential behavior that :

$$\lim_{P \rightarrow \infty} \frac{dP}{d(\log(T))} = A_0 \quad \text{where } A_0 \text{ is an asymptotic constant} \quad (1)$$

The latest version of the AGREGEE model offers four types of precipitation and discharge extrapolations: aesthetic, brutal, gradual and integrated (Margoum 1992, Margoum and Oberlin 1991) but operationally, only the first one is used.

Basically, the aesthetic AGREGEE extrapolates the discharges keeping the same behavior for the discharge pdf, on the extrapolated domain, as that of the precipitation pdf (figure 2).

It was shown (Oberlin and Margoum 1991, Margoum 1992) that for the aesthetic extrapolation of maximum precipitation and discharges we may write :

$$Q(T) = \frac{A_0}{K_p - K_q} \left[K_p \cdot \log \frac{T + K_p}{T_g + K_p} - K_q \log \frac{T + K_q}{T_g + K_q} \right] \quad (2)$$

where all parameters were defined above.

3.2 The regional analysis and transfer of maximum discharge quantiles - the QdF models

In order to represent in a synthetic form all the discharge quantiles computed by AGREGEE, are drawn the discharge-duration-frequency curves, for all the analyzed duration and mean return periods, this type of diagrams being called "QdF curves" (figure 3).

The QdF curves (Oberlin et al. 1988, Galéa et al. 1990, Galéa and Prudhomme 1993) represent a synthetic description of the regional characteristics of the hydrological regime of a basin. The analytical expressions of the QdF curves are called "QdF models".

As regionalization models they are relating, in a synthetic form, the characteristic hydrological parameters (the discharge quantiles for different duration and mean return periods) to basin physiographic and climatic characteristics (maximum precipitation and discharge gradexes, the basin flood characteristic duration D and the annual maximum instantaneous decennial discharge QIXA10).

For mean return periods T, within the range of 0.5 to 20 years, the QdF models may be expressed as :

$$Q(T, d) = G_q * \ln(T) + Q_0 \quad (3)$$

where Q(T, d) is the maximum discharge on duration d and mean return period T, G_q(d) is the "gradex" (slope) of the measured discharge quantiles and Q₀ is the equivalent of a position parameter (Galéa and Oberlin 1989, Michel and Oberlin 1987a, Oberlin 1987).

For mean return periods within the range of 20 to 1000 years, the QdF models can be expressed as (Michel and Oberlin 1987a, Galéa 1987, Galéa and Prudhomme 1994) :

$$Q(T, d) = Q(T_g, d) + QIXA10 * G_p(d) * \ln \left[1 + \frac{G_q(d)}{G_p(d)} * \left(\frac{T}{T_g} - 1 \right) \right] \quad (4)$$

where G_p(d) is the precipitation gradex on the duration d and T_g is the extrapolation threshold (variable but usually 10 years).

The QIXA10 and the D values for the ungauged sites, are usually computed from regional analysis or by correlating these values with the local physiographic and/or climatologic characteristics of the basin.

The general validity of the QdF models it is assumed to be within the range of 0.0003 to 720 hours for the duration, within the 0.5 to 1000 years for the mean return periods and within the range of 0.001 till 5000 Km² for basin areas (Galéa et al. 1990, Galéa and Prudhomme 1993).

Galéa et al. (1989) has shown that in their normalized form, the QdF curves for the gauged stations may be transposed to other sections of the same basin, or to other ungauged homologous basins.

The condition of transpozability of the normalized QdF models implies (in normalized duration) :

$$\left(\frac{d}{D} \right)_{\text{gauged st.}} = \left(\frac{d}{D} \right)_{\text{ungauged st.}} \quad (5)$$

consequently, for the normalized discharge quantiles, one may write (Galéa 1987, Oberlin et al. 1989) :

$$(Q(T,d/D)/QIXA10)_{\text{gauged st.}} = (Q(T,d/D)/QIXA10)_{\text{ungauged st.}} \tag{6}$$

from which one may compute the maximum discharge quantiles $Q(T, d)$ for the ungauged site in a basin, for any duration d and mean return period T .

This assumption allows the calculation of the maximum discharge quantiles for all the ungauged sections in a basin with characteristics (regarding the maximum runoff formation) homologous to the gauged basin.

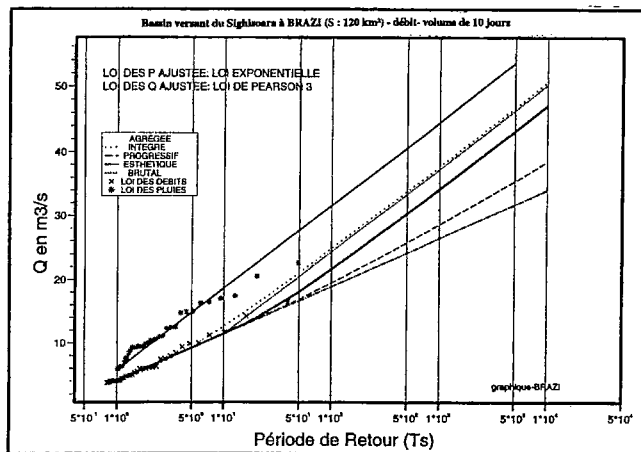

Figure 2 : Discharge extrapolation in the AGREGEE model at Brazi (Sighisoara basin)
 Figure 2 : Extrapolation des débits selon AGREGEE à la station de Brazi

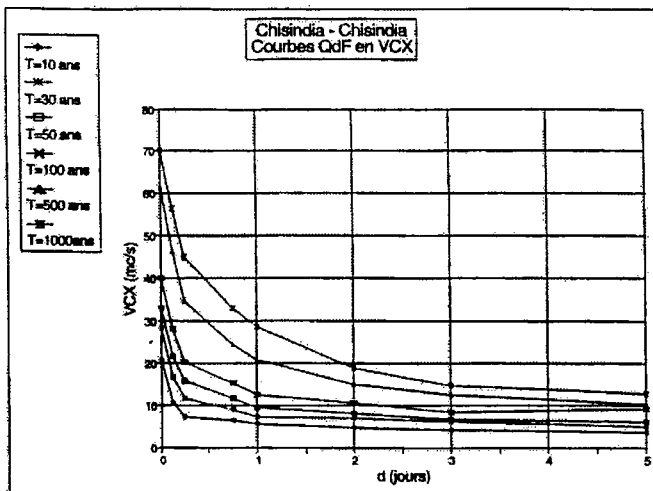

Figure 3 : QdF curves at Chisindia gauging station (Crisul Alb river)
 Figure 3 : Courbes QdF à la station de Chisindia

In order to assure the transposability of the QdF models, as well as to underline the local basin characteristics QIXA10 and D, the QdF models are rewritten in the following form :

$$Q(T,d) = (C_1 * \ln(T) + C_2) * QIXA10 \tag{7}$$

for mean return periods within the range 0.5 till 20 years, and :

$$Q(T,d) = Q(T_g, d) + C_3 * \ln \left[1 + \frac{C_1}{C_3} * \left(\frac{T}{T_g} - 1 \right) \right] * QIXA10 \tag{8}$$

for the mean return periods within the range of 20 till 1000 years, respectively.

The coefficients C_i ($i = 1, 2, 3$) has been expressed as (Michel and Oberlin 1987b, Galéa 1989) :

$$C_i = 1/(X_j * d/D + X_{j+1}) + X_{j+2} \quad \text{with } j=3i-2 \quad (9)$$

where the parameters X_j are to be determined using a numerical optimization technique from the registered discharge and precipitation series at the gauged stations in the analyzed area, whereas D and $QIXA10$ values, for the ungauged stations, are computed based on regional synthesis performed for the chosen region.

Numerous studies performed in France and in some other countries, participating in the UNESCO PHI-V/FRIEND-AMHY project (Galéa et al. 1990, Oberlin and Margoum 1991, Galéa and Prudhomme 1994, Oancea et al. 1992), allowed the identification of only three main types of QdF models (for VCX discharge type), for all hydrological regimes types tested, named, by the French gauging stations where they were first identified, as : Soyans, Vandenesse and Florac. Based on the QdF models (QCX type) one may compute the synthetic mono-frequency hydrographs-SMFH (Oberlin et al. 1988, Margoum and Oberlin 1992, Oberlin and Margoum 1991, Oancea et al. 1992, Margoum 1993, Galéa and Prudhomme 1994) for different return periods, the necessary input of the hydraulic integrated model of the basin.

3.3 The Synthetic Hydrograph Design - the SMFH model

The QdF models (QCX type) previously introduced can give all the necessary information for the hydraulic behavior description of maximum discharges in an extremely condensed form. The INONDABILITE hydraulic model of unsteady channel flow, needs as input flood hydrographs, which are mono-frequency (all the points of the flood hydrograph have the same frequency of exceedence). These types of hydrographs are called Synthetic Mono-Frequency Hydrographs (SMFH), where "synthetic" is used to recall their "un-natural" nature as well as their design manner.

The mono-frequency synthetic hydrograph design is based on the following assumptions (figure 6) :

- i. the increasing branch of the flood hydrograph is linear within the coordinates (0, 0) and (Q_{IX} , t_m), where t_m is the raising time and Q_{IX} is the peak flood discharge ;
- ii. the recession branch ($t > t_m$) is given by the QdF model/curve (previously identified), with an adequate shift of temporal abscissa :

$$t_i^* = t_i + t_m * Q(T, d_i) / Q_{IX}(T) \quad (10)$$

where t_i^* is the SMFH shifted abscissa, t_i and $Q(T, d_i)$ are the initial abscissa and the discharge quantiles (VCX or QCX) of mean return period T and for the duration d , respectively, of the QdF model/curve previously identified (Gilard and Oancea 1992, Oancea 1994).

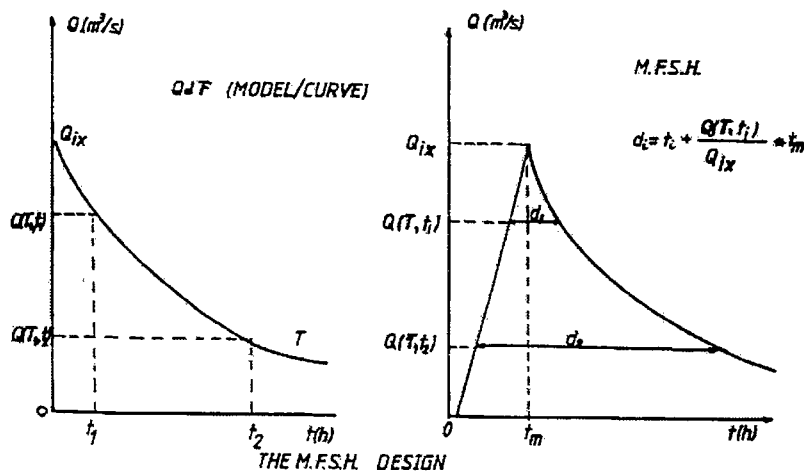

Figure 6 : Mono-frequency Synthetic hydrographs design in the INONDABILITE model
 Figure 6 : Hydrogrammes synthétiques mono-fréquence du modèle INONDABILITE

4 The NIMH method

The NIMH method uses an at-site frequency analysis step, for the annual maximum instantaneous precipitation intensities and discharges (PIX/QIX) and/or for the peaks-over-threshold series (POT), to compute the quantiles values for all necessary duration ($Q_T(d)$).

In a second step, the same type of analysis is performed for the maximum flood volumes of different duration, corresponding to the maximum discharges selected before, providing the maximum quantile volume values of different T-year mean return period ($W_T(d)$).

In a third step, the at-site calculation is followed by a regional homogeneity and consistency analysis, to assure the uniform computation of maximum runoff characteristics as well as the spatial interpolation of the necessary parameters for the Synthetic Hydrographs (SH) design at the ungauged sites of the basin.

The maximum discharges (peak values and maximum discharge averages over different duration), the maximum corresponding volumes and the basin flood parameters previously computed from the at-site and regional analyses are used to design the synthetic hydrographs (SH) needed further as input in the simplified basin hydraulic model.

As for the INONDABILITE model, in the following only the steps necessary for the SH design are detailed.

4.1 The discharge extrapolation

The NIMH method used for the maximum precipitation intensity's extrapolation is the exponential pdf, while for discharge's extrapolation, the Pearson 3 probability distribution function was used.

If T is the mean return period of the T-year maximum value X_T , the non-exceedence probability $P(x \leq X)$, of X_T , may be written as (Kite 1977, Kritzky and Menkel 1969) :

$$P(x \leq X) = \int_{x_0}^x f(x, a, b, c) dx = 1 - 1/T \quad (11)$$

where a, b, c denote the slope, scale and location parameters of the three-parameter pdf.

The values of the population parameters are estimated usually using the method of moments. Since, usually, the used maximum discharge series have short lengths the computed parameters must be corrected for bias, especially the CS values (Kite 1977, Brunet-Moret 1969, Rossi et al. 1984).

The Pearson 3 pdf may be written as (Bobe and Ashkar 1988) :

$$f(x) = [(x - c)/b]^{(a-1)} \exp[-(x - c)/b] / [b \cdot \Gamma(a)] \quad (12)$$

where $\Gamma(a)$ is the complete gamma function.

Although $F(x)$ for the three-parameter gamma distribution is not analytically expressible, there are some numerical methods available to calculate it. The values of the maximum discharge and precipitation intensities are computed using the classical frequency factor equation :

$$Q_T = ab + c + |b| \cdot \sqrt{a} \cdot K_g \quad (13)$$

where Q_T is the T-year maximum value and K_g is the gamma frequency factor.

For the POT series, the classical model assumes that the occurrence of the maximum values is Poisson distributed over the year period. Denoting by N the number of exceedences in t years, the pdf of N becomes (Bernier 1967, Rosbjerg et al. 1992) :

$$P(N = n) = (\beta t)^n \exp(-\beta t) / n! \quad \text{with } n = 0, 1, 2, \dots \quad (14)$$

where β equals the expected number of exceedences per year.

In the classical approach, the exceedences magnitudes are assumed to be independent and identically distributed following the exponential distribution (ED) :

$$f(x) = (1/a) \exp(-x/a), \quad \text{with } x \geq 0 \quad (15)$$

with mean and variance $E\{X\} = a$ and respectively $\text{Var}\{X\} = a^2$ and with the maximum likelihood estimators for a and β :

$$a = \sum_{i=1}^N x_i / N \quad \text{and } \beta = N / t .$$

For a Poisson-distributed variable the mean and the variance are identical, assumption that some time is difficult to justify. However, in the present study this hypothesis was assumed for the maximum precipitation intensities, as well as the Pearson 3 pdf for the maximum discharge values.

4.2 The regional analysis of maximum runoff characteristics

In to assure the consistency of the at-site estimates for the entire analyzed area, as well as to allow the estimation of maximum discharge quantiles for the ungauged sites of the studied region, a regional analysis of the maximum runoff characteristics (maximum precipitation intensity and discharge quantiles, basin flood parameters, etc.) is performed. Roughly speaking, the regionalization techniques used in NIMH method, try to establish correlations between the maximum runoff characteristics and the local basin and climatic factors (basin area and mean altitude, the length of the main basin river, etc.), which are supposed to be homogenous over the analyzed region, as well as to identify some “main regional behaviour” of the maximum runoff parameters in the analyzed area (the “main regional behavior” being given either by an evident “trend” of the majority of the analyzed station's value parameters, or by just a few very reliable gauging stations, usually those on the main river, with the longest records, etc.).

In figure 7 the regional curves of the basin flood parameter's t_c , D and t_t , were correlated with the sub-basin areas, while in figure 8 the regional variation of 10 and 100-years mean return period, respectively, maximum specific discharges (q_{IXA10} , $q_{1\%}$ and $q_{IX1\%}$) was analyzed. When the correlation with the basin area it is not suitable, the mean altitude of the basin proved to be a very convenient variable in describing the maximum runoff parameter behavior. Sometimes, correlation with the length of the sub-basins could also be useful in generalizing specific behaviors across the analyzed region.

These types of correlations allow a kind of “spatial interpolation” of the maximum runoff parameters, and ensure the necessary values for the synthetic hydrograph design all over the studied area (Cunnane 1988).

4.3 The synthetic hydrograph (SH) design

In the NIMH method the synthetic hydrograph design technique uses all the maximum runoff parameters previously computed from at-site analysis of maximum and rare floods and/or, in the case of unavailable data, the regional values.

The SH design technique is based on the following assumptions (figure 9) :

- i. the peak value of the T-year SH is the annual maximum instantaneous T-year discharge value, computed from the at-site or regional analysis ;
- ii. the raising and depletion SH branches are exponential ones, but in such a manner that both, the mean basin flood shape γ and the T-year maximum volume be fulfilled (the maximum T-year volume quantile has such a time distribution that the mean shape parameter is γ) ;
- iii. the peak flood abscissa is t_c and the total flood hydrograph duration is t_t (previously computed from at-site and/or regional analysis).

The values of t_c , t_t and γ are computed as median of the at-site registered values and then smoothed in a regional analysis step, in which they can suffer corrections accordingly with the main regional behaviour in the analyzed area.

The SH peak value and the associated maximum volume are giving the hydraulic design values, while the t_c , t_t and especially γ , are giving the time distribution of the designed synthetic hydrograph.

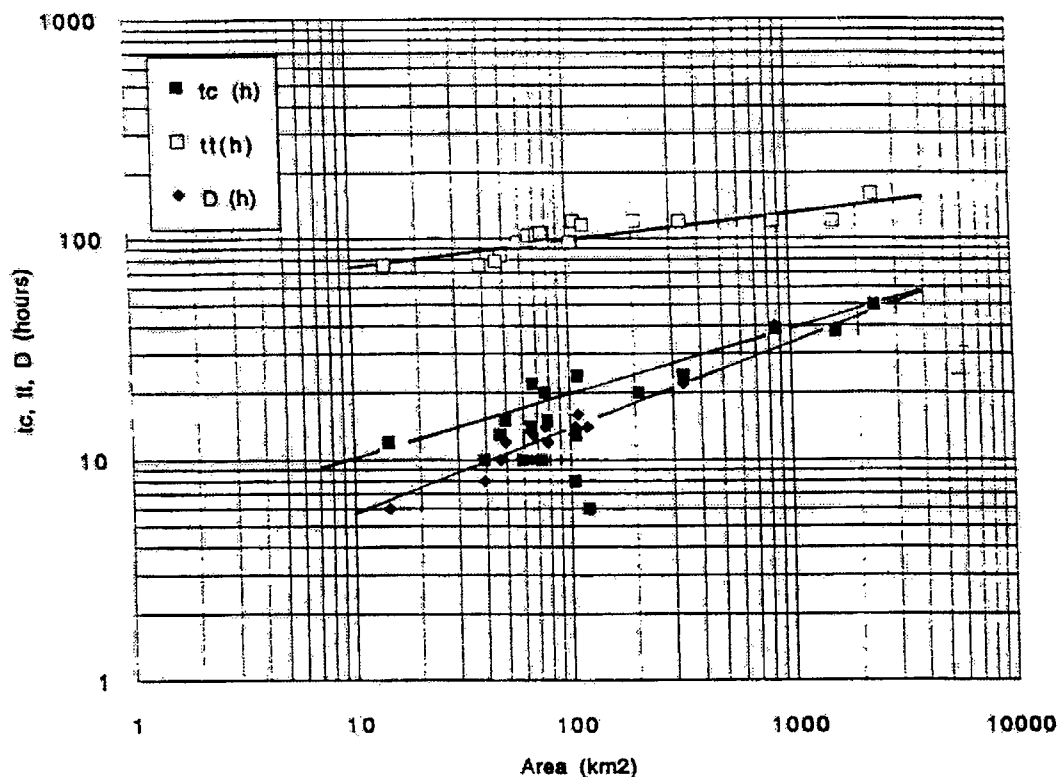

Figure 7 : Regional curves of basin flood duration parameters t_c , t_t and D
 Figure 7 : Courbes régionales pour les paramètres de durées de crues t_c , t_t et D

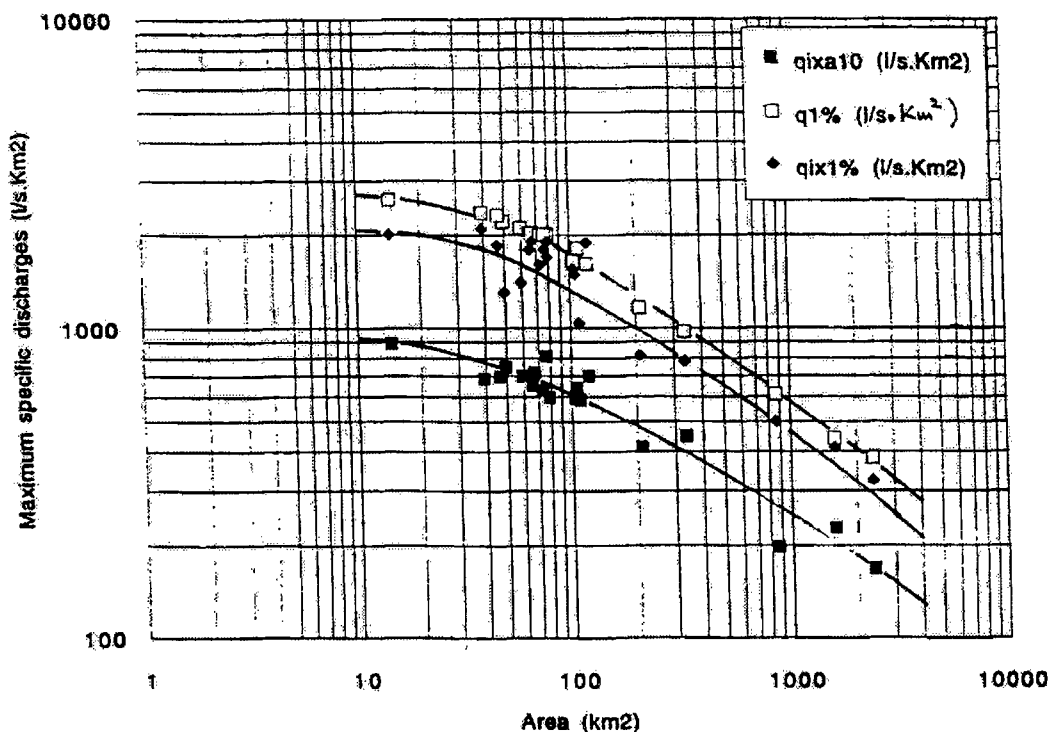

Figure 8 : Regional curves of maximum specific discharges of 10 and 100 years mean return period, respectively (q_{10} , $q_{1\%}$ and $q_{100\%}$), on the Crisul Alb river
 Figure 8 : Courbes régionales pour les débits de pointe spécifiques décennaux et centennaux sur la rivière Crisul Alb

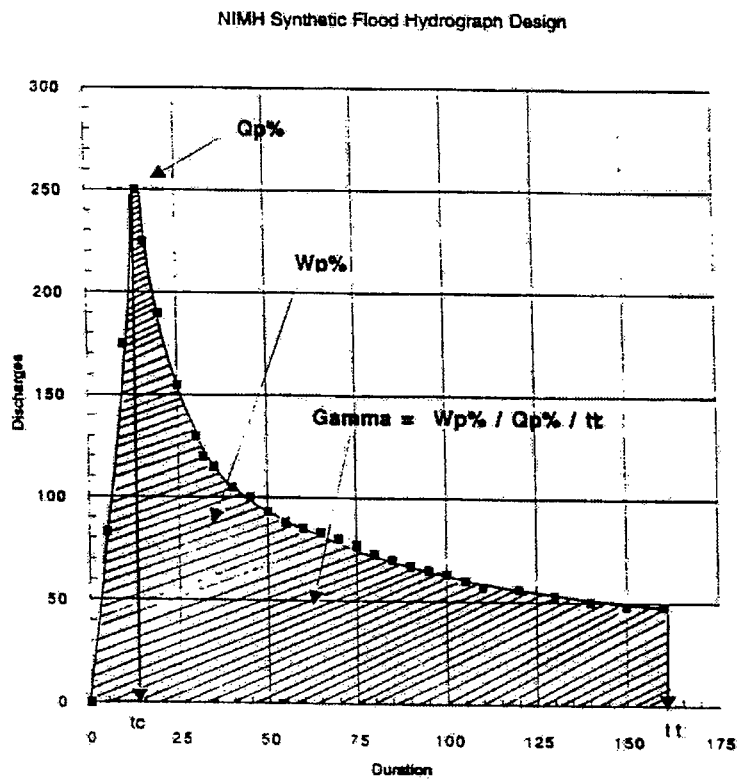

Figure 9 : NIMH method synthetic hydrograph design

Figure 9 : Méthode de l'INMH pour les hydrogrammes de projet

5 Main results and comments

5.1 The INONDABILITE model

The pdf analysis and extrapolation of maximum discharges and precipitation intensities (the model AGREGEE) was performed for all gauging stations in the basin with the precipitation stations : Tebea for the upper part of the basin (stations 1-10 in Table 1) and Gurahont for the lower part of the basin (stations 11-20 in Table 1), respectively.

For the majority of analyzed series of maximum precipitation intensities, the exponential pdf gave the best results of the used statistical goodness of fit tests. The same type of pdf analysis have been performed for all the maximum discharge series available in the Crisul Alb basin. In Table 1 are listed the maximum instantaneous discharges of 100-years mean return period ($QIX_{1\%}$) for the analysed stations, at this stage of the analysis all other quantiles being available for duration between 1 hour and 500 hours, and mean return periods between 1 year and 1000 years, as standard output of the AGREGEE model.

In the next step, the previous computed quantiles, served at the QdF curve's design (in Figure 3 is given the QdF curves analysis at Chisindia gauging station on Chisindia tributary) and for the QdF model identification. A preliminary step in QdF model identification is the normalization of the QdF curves which are then compared with the similar values of the analytical QdF models . As a measure of the goodness of fit between the normalized curves and the model values, the Nash criterion and the correlation coefficient were used. In this particular case the QdF model Vandenesse gave the best results (in a few cases the Florac model gave also statistically acceptable results, but for the sake of simplicity of the analysis we preferred to use only the Vandenesse model in the analysis), and further

on, for the MFSH design, only this model has been used (in Figures 11 - 14 some of the designed MFSHs are presented).

Table 1 : The main characteristics of the synthetic hydrographs at the analyzed stations in the Crisul Alb basin

Table 1 : Les principales caractéristiques des hydrogrammes synthétiques analysés dans le bassin du Crisul Alb

No	River	Station	QIX _{1%} SMFH	Q _{1%} NIMH (m ³ /s)	D (hours)	t _c (hours)	t _t (hours)	γ
1	Crisul Alb	Blajeni	158	180	14	13	96	0.24
2	Valea Satului	Bucesi	161	172	13	8	96	0.24
3	Bucuresci	Bucuresci	82.9	125	10	10	96	0.20
4	Crisul Alb	Crisior	261	325	22	24	120	0.25
5	Luncoi	Brad	118	133	10	14	98	0.23
6	Ribita	Ribicioara	82.3	92.5	8	10	76	0.22
7	Vata	Vata de Sus	134	156	15	15	96	0.21
8	Crisul Alb	Vata de Jos	430	525	40	39	120	0.31
9	Halmagel	Halmagel	127	136	13	22	103	0.21
10	Banestilor	Halmagiu	113	198	16	24	120	0.22
11	Sighisioara	Brazi	227	194	14	6	112	0.22
12	Crisul Alb	Gurahont	654	700	39	38	120	0.3
13	Valea de Lazuri	Virfurile	149	158	12	15	106	0.23
14	Iasu	Iosasel	117	146	10	10	104	0.20
15	Moneasa	Moneasa Boroaia	28.7	37.3	6	12	76	0.20
16	Moneasa	Moneasa	64.4	109	12	15	84	0.20
17	Moneasa	Ranusa	137	153	14	20	106	0.22
18	Sibis	Sebes	170	243	20	20	120	0.26
19	Chisindia	Chisindia	86.6	108	10	13	79	0.22
20	Crisul Alb	Bocsig	770	910	50	50	160	0.30

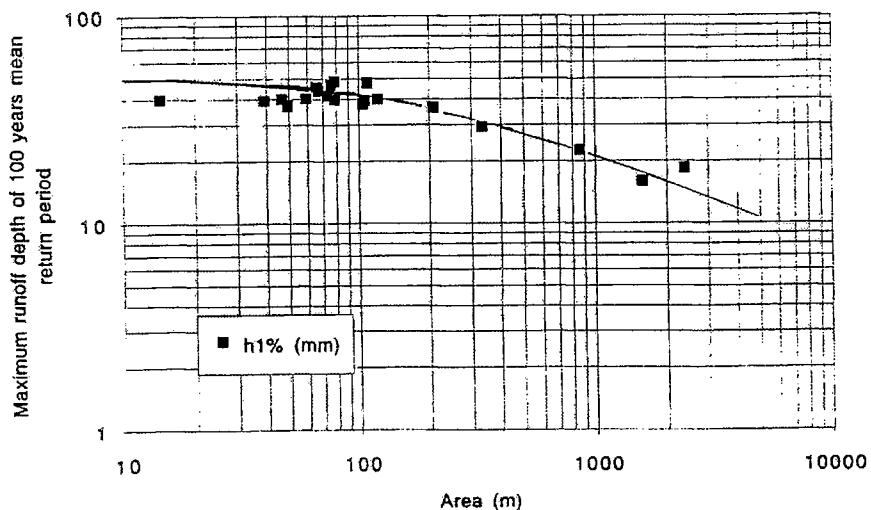

Figure 10 : Area variation on the Crisul Alb river basin of the maximum runoff depth of 100 years mean return period

Figure 10 : Variation des écoulements centennaux de crue (totale) selon la surface du bassin, sur le Crisul Alb

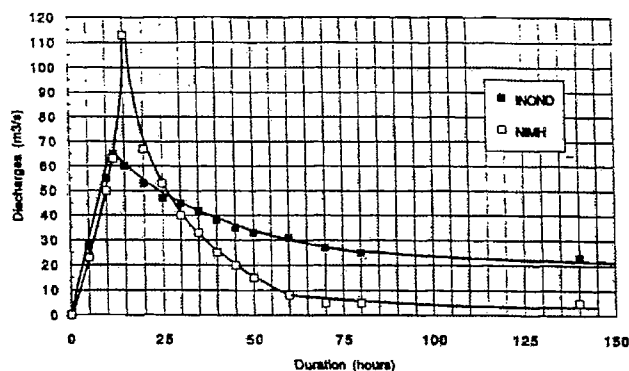

Figure 11 : Computed synthetic hydrographs of 100 years mean return period by NIMH and INONDABILITE method for Moneasa gauging station (Moneasa tributary)

Figure 11 : Hydrogrammes synthétiques «centenaux» selon les méthodes INMH et HSMF sur la Moneasa à Moneasa

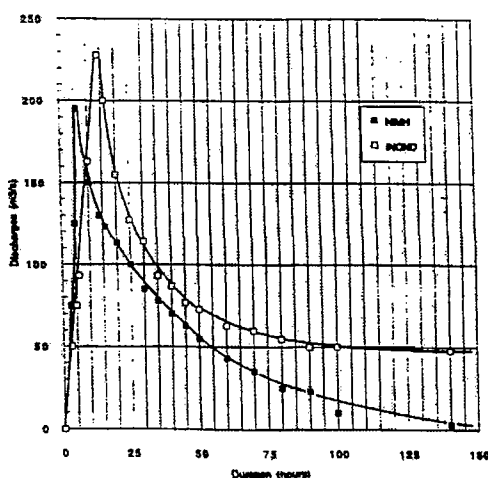

Figure 12 : Computed synthetic hydrographs of 100 years mean return period by NIMH and INONDABILITE method at Brazi gauging station (Sighisoara tributary)

Figure 12 : Hydrogrammes synthétiques «centenaux» selon les méthodes INMH et HSMF sur le Sighisoara à Brazi

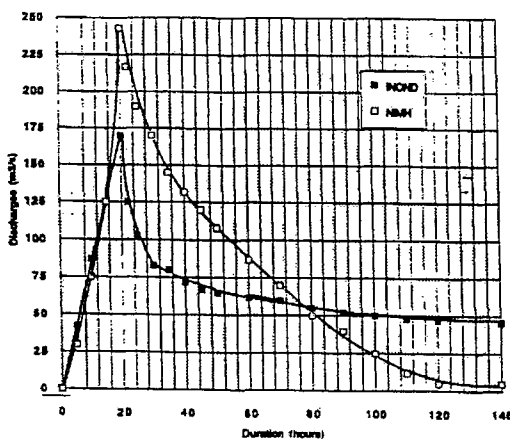

Figure 13 : Computed synthetic hydrographs of 100 years mean return period by NIMH and INONDABILITE method at Sebis gauging station (Sebis tributary)

Figure 13 : Hydrogrammes synthétiques «centenaux» selon les méthodes INMH et HSMF sur le Sebis à Sebis

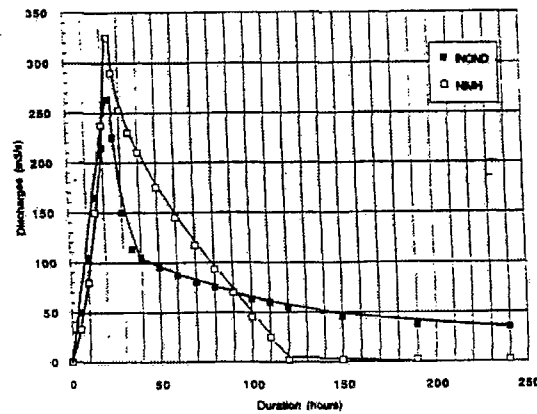

Figure 14: Computed synthetic hydrographs of 100 years mean return period by NIMH and INONDABILITE method at Criscior gauging station (Crisu Alb tributary)

Figure 14: Hydrogrammes synthétiques «centenaux» selon les méthodes INMH et HSMF sur le Crisu Alb à Criscior

5.2 The NIMH method

The classical step of pdf analysis and extrapolation of maximum discharges and runoff volumes have been performed for all analyzed stations of Crisu Alb basin, using the Pearson 3 pdf, for all the necessary duration of SH design (usually between t_c and t_t).

In Table 1 is given the maximum quantiles of 100 years mean return period ($Q_{1\%}$), which in NIMH method are used as reference values in the regional analysis of maximum runoff characteristics, the next step in SH design.

From the selected maximum flood hydrographs, that provided the maximum discharge and volume values, has been selected the values for the at-site analysis of the basin flood hydrograph characteristics: t_c (the raising time), t_t (the total duration) and γ (the shape parameter). The final values, for the basin flood hydrograph, are obtained as median of the computed individual values and Table 1 is displaying that one for the Crisu Alb basin analyzed stations.

In the NIMH method, a first step in setting the regional behavior of maximum runoff genesis is given by the analysis of the mean slope variation of the studied sub-basins. As it can be seen, the smooth variation of this parameter within the basin area suggests a relatively uniform distribution of the potential contributing areas over the basin with no “unusual” zones.

The same type analysis performed for the basin flood hydrograph parameters (t_c , t_t and γ) and D (figure 7) suggests also a certain uniform variation of these parameters over the basin area. This regional behaviour of the basin flood hydrograph parameters is also confirmed by the areal variation of the basin flood shape parameter and the dependence of the basin flood characteristic duration D .

The corner stone of the regional analysis in the NIMH method is the regional variation of the 100 years mean return period maximum discharges, namely their specific values (figure 8). To facilitate the comparison with the same type of results provided by the INONDABILITE model, the maximum quantiles computed by the AGREGEE model were plotted on the same graph as that one computed by NIMH method (in figure 8, the $q_{ix 1\%}$ curve).

The final confirmation of the main regional behaviour of the maximum runoff characteristics, computed previously, is given by the maximum runoff depth of 100 years mean return period ($h_{1\%}$) analysis on the entire basin, which include in its analytical expression the maximum specific discharge, the basin flood shape parameter and the basin flood total time values (of the same mean return period). The smoothed variation within the basin area, without unexplained “jumps”, of our maximum runoff depth of 100 years mean return period (presented in Figure 10) confirmed the previous computed values of the maximum runoff characteristics on Crisu Alb basin. These types of regional curves allow the computation of all necessary parameters for the SH design, as they were

defined for the NIMH method in the previous paragraphs, the resulting SH being presented in Figures 11-14 at the same gauging stations as for the INONDABILITE model.

6 Conclusions

As a general remark of the INONDABILITE and NIMH results comparison, the NIMH synthetic hydrographs are “larger” than the INONDABILITE MFSHs. This result was rather surprising while we expected that the support, in AGREGEE, by the maximum precipitation pdf of the corresponding maximum discharge's extrapolation, will “increase” significantly the upper tail of the discharge pdf. Or, in fact, the direct extrapolation of discharge series gave higher values. This unexpected result can be however explained, to a certain extent, by the lack of significant great values in the analyzed maximum precipitation intensities and discharges. This effect was on both methods, for INONDABILITE that has been quite completely automatisized in the extrapolation module (in AGREGEE the operator direct intervention in the extrapolation process is minimal), the lack of higher values in the precipitation and discharge series gave low gradexes and therefore “low” extrapolated values, while in NIMH method, more “manual”, the “hydrological feeling” of the human operator pushed the extrapolated curve tail “upper” through the “safer” values.

Nevertheless, the differences between the peak values provided by INONDABILITE model and NIMH methods are within the range of 7% to 27%, which from the operational point of view are still acceptable (there was a single exception for the smallest analyzed basin, at 14.3 Km², where the peak value difference between the two methods was 78%).

A rather larger difference is in the time distribution of maximum volumes of the computed flood hydrographs.

Although, quantitatively, the computed maximum volumes by the two methods, differed by 17% to 31% (again the greater differences were for smaller areas), their time distribution can be sometimes dramatically different (figures 11 - 14 for example).

There are some major differences in the time distribution techniques that the two methods use. The INONDABILITE model supposes all the points on the synthetic hydrograph of the same frequency (given mean return period), its time distribution being given by the QdF model values (with a small time “shift” due to the linear raising branch).

In the NIMH method, only the volume value, for a given mean return period, is computed, its time distribution being specified by the parameter's t_c and t_t (which limit the time axis for the flood hydrograph) and, especially, by the basin flood shape parameter (which precise the manner in which the volume will be distributed within these limits). Therefore the points of NIMH method synthetic flood hydrograph have no more the same mean return period, as the peak flood and the volume value, and even we don't know what mean return period they have (actually we can compute the mean return period of each point of the NIMH method synthetic hydrograph but it is useless).

From this point of view the comparison of the time behavior of the two computed synthetic hydrographs become insignificant.

It must also be recalled that the MFSH was created do allow a fine mapping of any flood hazard characteristic, and not to represent a realistic hydrograph. The MFSH is a synthesis tool representative of the regime in discharge-thresholds values (QCXd), not a tool for representing hydrographs. It has nevertheless internal volumes which are in agreement with the discharge-volumes (VCXd) regime. So, the future of such comparison could perhaps be to follow the applications until the INONDABILITE level. But the NIMH approach is presently not yet directly adapted to map flood hazards and vulnerabilities.

Renewal processes for flood analysis

Analyse des crues par la théorie de renouvellement

V. Vukmirovic and J. Petrovic

1 Introduction

Floods are natural phenomenon and they depend on numerous geophysical, climatic and other characteristics of the region. Therefore their major characteristics such as peak flow, time of occurrence, flow volume or flood duration cannot be predicted with certainty. This means that floods are typical random (stochastic) processes and that they should be considered with the aid of statistical and stochastic methods for analysis of hydrological observations.

Peak flow is the most frequently used variable in flood analysis, and the annual maxima series approach is the most frequently used method for probabilistic assessment of design flows. The annual maxima series considers only one value of design variable (e.g. peak flow) per year, i.e. annual maximum. The limitation of the annual maxima method is that some insignificant flow values from dry years are included in annual maxima series, while some significant ("the second greatest") values are not considered.

To overcome this limitation, another kind of series can be considered and that is the partial duration series or peaks over threshold (POT) method. The POT series includes all values exceeding a certain threshold value, so that several peaks from one year can be included. When considering the POT series, it is necessary to determine the number of peaks in a year and to combine their probability of occurrence with probability distribution of peak exceedances over the threshold in order to obtain a distribution function of annual maximum flows.

The POT method can also be used in the assessment of volume, time to peak or the duration of flood hydrograph, as well as the seasonal flood flow characteristics. The seasonal analysis (compound POT method) combines distributions of seasonal flow maxima in order to estimate the probability distribution of annual flood maxima.

2 The POT Method

The series of maximum flow values considered in the POT method consists of all peak flows X in the N -years record that exceed a chosen threshold value x_B . Two main variables in the POT method are the number of peaks in each year v and the flow exceedance (peak) over threshold $Z = X - x_B$. The occurrence of annual maximum flows is a random process defined with :

$$\chi(t) = \sup_{v \geq 1} Z_v, \quad Z_v = X_v - x_B \quad (1)$$

The distribution function of annual maxima is :

$$F(x) = P\{\chi(t) \leq x\} \quad (2)$$

To obtain this distribution function it is necessary to combine the probabilities of occurrence of the two main variables: number of peaks v and flow exceedance (peak value) Z .

2.1 Number of peaks

The number of peaks during the interval $(0, t)$ – one year in this analysis – is a random variable η_t , which can take values 0, 1, 2, ... with probabilities $p_v(t) = P\{\eta_t = v\}$. The occurrence of peaks during a time interval is a Markov renewal process with the intensity function:

$$\lambda(t, v) = \lim_{\Delta t \rightarrow 0} \frac{P\{[\eta(t + \Delta t) - \eta(t)] = v\}}{\Delta t} \tag{3}$$

The probability of occurrence of peaks is given by

$$\begin{aligned} p'_v(t) &= \lambda(t, v-1)p_{v-1}(t) - \lambda(t, v)p_v(t) \\ p'_0(t) &= -\lambda(t, 0)p_0(t) \end{aligned} \tag{4}$$

The solution of equations (4) represents the probability law of occurrence of peaks and depends on the form of the intensity function λ . For three different forms of this function three well-known models for the number of peaks are obtained: Poisson, Bernoulli (binomial) and Pascal (negative binomial). Table 1 summarizes the major characteristics of these models. It is of practical importance to note that the dispersion index (ratio between variance and expectation of random variable) is 1 for the Poisson model, it is smaller than 1 for the binomial model and greater than 1 for the negative binomial model.

An example of the distribution for the number of peaks is shown in Fig. 1, for which Poisson's model was used.

Table 1 : Three different models for the number of peaks

Table 1 : Trois différents modèles pour l'occurrence du nombre de pointes

model for the number of peaks	intensity function $\lambda(t, v)$	probability of v peaks $p_v(t)$	dispersion index $I(\eta_t)$
Poisson	$\lambda(t)$	$\Lambda^v e^{-\Lambda} / \Gamma(v+1)$	1
Bernoulli (binomial)	$\lambda(t)(1 - v/a)$	$C_a^v e^{-\Lambda} (e^{\Lambda/a} - 1)^v$	$e^{-\Lambda/a} < 1$
Pascal (negative binomial)	$\lambda(t)(1 + v/b)$	$C_{b+v-1}^v e^{-\Lambda} (1 - e^{-\Lambda/b})^v$	$e^{\Lambda/b} > 1$

Note: $\Lambda = \int_0^t \lambda(s) ds$, $C_a^v = \frac{\Gamma(a+1)}{\Gamma(v+1)\Gamma(a-v+1)}$, $C_{b+v-1}^v = \frac{\Gamma(b+v)}{\Gamma(v+1)\Gamma(b)}$

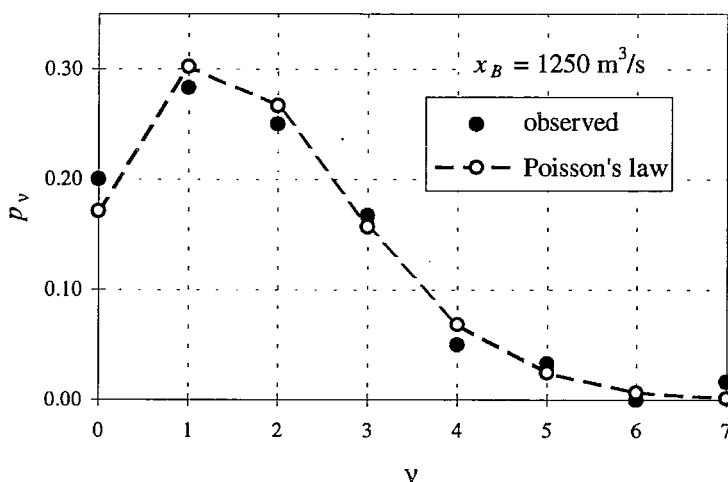

Figure 1 : Example for distribution of the number of peaks (river Sava at Radece).
Figure 1 : Exemple de distribution de l'occurrence du nombre de pointes

2.2 Peaks over threshold

The distribution function for flow peaks is defined by :

$$H(z) = P\{Z \leq z\} \quad (5)$$

This distribution can be generalized as a three-parameter gamma distribution with the density function:

$$h(z) = \frac{a\Gamma^k\left(\frac{k+1}{a}\right)\left(\frac{z}{\mu}\right)^{k-1}}{\mu\Gamma^{k+1}\left(\frac{k}{a}\right)} \exp\left\{-\left[\frac{\Gamma\left(\frac{k+1}{a}\right)}{\Gamma\left(\frac{k}{a}\right)}\right]^a\left(\frac{z}{\mu}\right)^a\right\} \quad (6)$$

Distributions like the two-parameter gamma, Weibull's, Rayleigh's, Erlang's or the exponential distribution are special cases of this general distribution. Two types of distributions are usually employed to describe the magnitude of peaks over threshold:

$$\text{Exponential: } H(z) = 1 - \exp(-z / \mu)$$

$$\text{Weibull: } H(z) = 1 - \exp[-(z / \beta)^\alpha] \quad (7)$$

The exponential distribution is a special case of the Weibull distribution for $\alpha = 1$. It is recommended that the one-parameter or two-parameters distributions are used for fitting the observed flow peaks so that the distribution of annual maxima does not have more than four parameters. An example where the two-parameter Weibull distribution was applied is shown in Fig. 2.

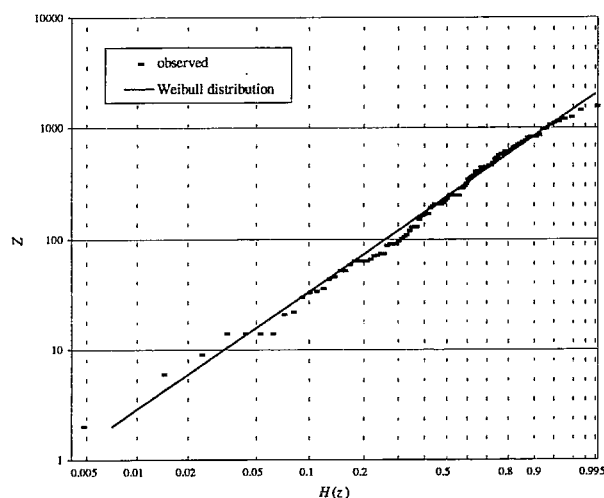

Figure 2 : Example of the distribution of peaks (river Sava at Radece).

Figure 2 : Exemple de distribution des débits de pointes

2.3 Annual maxima

The distribution of annual maxima is obtained by combining the distributions of the number of peaks and the distribution of peaks over threshold (Todorovic, 1970) :

$$F(x) = p_0 + \sum_{v=1}^{\infty} [H(x - x_B)]^v p_v(t) \quad (8)$$

If the number of peaks follows Poisson's law, distribution function $F(x)$ has the form :

$$F(x) = \exp\{-\Lambda[1 - H(x - x_B)]\} \quad (9)$$

This simple form has found wide application, but problems may arise concerning the choice of the threshold value. Smaller thresholds in some cases give a number of peaks whose distribution is not a Poissonian. A greater threshold allows Poisson's law to be followed, but the total number of peaks is then reduced and this affects the reliability of the statistical inference. Fig. 3 presents an example of final distribution of annual maxima where the two distributions (Figs. 1 and 2) were combined.

By introducing the binomial (Bernoulli's) or negative binomial (Pascal's) distributions for the number of peaks (see Table 1) this problem can be overcome. The distribution of the annual maxima for the binomial distribution for the number of peaks is :

$$F(x) = e^{-\Lambda} [1 + (e^{\Lambda/a} - 1)H(x - x_B)]^a \quad (10)$$

and for negative binomial distribution for the number of peaks :

$$F(x) = e^{-\Lambda} [1 - (1 - e^{-\Lambda/b})H(x - x_B)]^{-b} \quad (11)$$

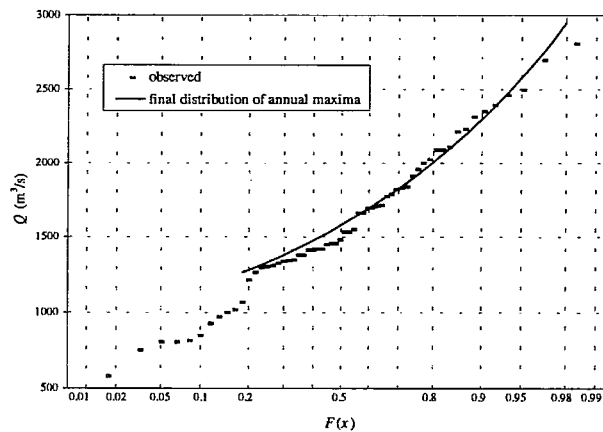

Figure 3 : Distribution of annual maxima (river Sava at Radece).

Figure 3: Distribution des maximums annuels (rivière Sava à Radece).

3 The Compound POT Method

The POT method can also be applied to seasonal annual maximum series, and it can also be used for obtaining annual extremes from seasonal distributions. In this latter case we refer to the POT method as the compound POT method.

If there are K seasons during the year, we assume for each season that the peaks are independent and identically distributed. The procedure for the compound POT method consists of two parts :

- (1) obtaining distributions of seasonal maxima using the POT method for each season, and
- (2) obtaining distributions of annual maxima by combining distributions of seasonal maxima.

In other words, the following distributions are obtained for each season :

- distribution of number of peaks p_{v_i} for each season ($i = 1, 2, \dots, K$),
- distribution of peaks over threshold $H_i(x)$, and
- distribution of seasonal maxima $F_i(x)$.

It was shown by Rouselle (1972) that the distribution function for the annual maxima can be defined as the compound probability of seasonal maxima as independent events :

$$F(x) = \prod_{i=1}^K F_i(x) \tag{12}$$

If the number of peaks in each season can be approximated by the Poisson distribution with parameter Λ_i , then the distribution function of annual maxima is given by :

$$F(x) = \exp\left\{-\sum_{i=1}^K \Lambda_i [1 - H_i(x)]\right\} \tag{13}$$

4 Example

The POT and the compound POT method will be illustrated with flows in the river Sava, from 1926 to 1985, at the station Radece, Slovenia. The POT method was applied for 11 different threshold values ranging from 1000 to 1500 m³/s. The best fit between the observed data and the theoretical distributions was obtained for the threshold of 1250 m³/s. Poisson's model was used for the number of peaks (Figure 1). Figure 2 presents distribution of peaks (106 peaks during 60 years) where the two-parameter Weibull distribution was applied. Using the parameters obtained for Poisson's model and the Weibull distribution, the distribution of annual maxima (see Figure 3) was calculated for values greater than 1250 m³/s.

The same series was used for seasonal analysis of flood flows and the application of the compound POT method. Peaks over the 1000 m³/s threshold were grouped in four seasons: winter (29 peaks), spring (26), summer (20) and autumn (76). Again, Poisson's model was used for the number of peaks and the two-parameter Weibull distribution for the magnitude of peaks. Goodness of fit for the Poisson model with frequencies of the number of peaks was tested with the chi-square test, and the significance levels were 35% for winter, 38% for spring, 54% for summer and 17% for autumn. An empirical distribution for the magnitude of peaks and the Weibull distribution were compared through the Kolmogorov-Smirnov test, with the following significance levels: 78% (winter), 76% (spring), 97% (summer) and 68% (autumn).

Figure 4 presents distributions of seasonal maxima, together with the distribution of annual maxima obtained with the compound POT method, according to equation (13).

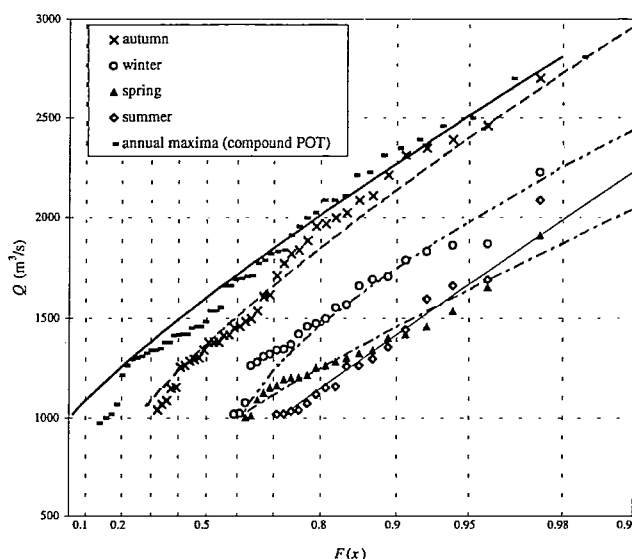

Figure 4 : Distributions of seasonal maxima and annual maxima (river Sava at Radece).
Figure 4 : Distribution des maximums saisonniers et annuels

Finally, different distributions of annual maxima can be compared in Figure 5, i.e. distributions obtained with the annual maxima method, the POT method and the compound POT method. For the annual maxima series the best fit was the three-parameter log-normal distribution.

5 Conclusions

The theoretical background of the peaks over threshold (POT) method was presented for the statistical analysis of maximum flows, together with an example of its application. The advantage of the POT method is that the POT series includes all flow values exceeding a certain threshold value, so that several peaks from one year can be included instead of only one maximum per year in case of annual maxima series. The limitation of the annual maxima method is that some insignificant flow values from dry years are included in annual maxima series resulting in a distribution function which underestimates flow quantiles; vice versa, some flow values slightly below the annual maximum may not be considered, resulting in the overestimation of quantiles. With the POT series this problem is eliminated, but the threshold above which the values are taken into account should be chosen with caution. If the threshold chosen is too high, the remaining flow values in the series are predominantly high values so that resulting distribution function can again be overestimated.

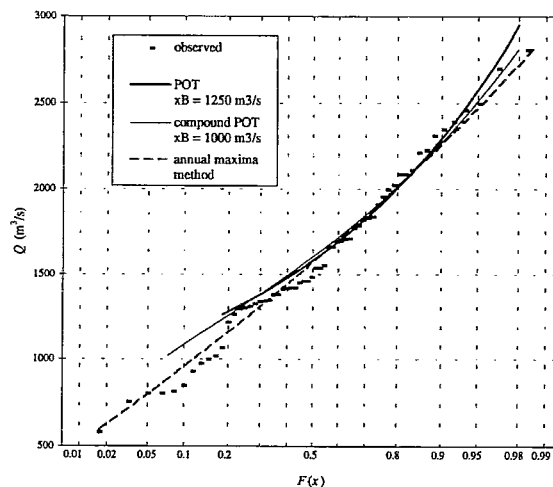

Figure 5 : Comparison between annual maxima, POT and compound POT methods (river Sava at Radece).

Figure 5 : Comparaision entre maximums annuels, valeurs sup.-seuils et composition de distribution de valeurs sup.-seuils

The application of the POT method consists of three steps. First, it is necessary to analyze the number of peaks (i.e. the number of peak occurrences in a year) as a discrete random variable. Second, the probability distribution of peak exceedances over the threshold is calculated. Finally, two distributions are combined to obtain the distribution function of annual maximum flows.

The POT method can also be used for assessment of other characteristics of floods, such as volume, time to peak or duration of the flood hydrograph. In these cases the procedure is the same as that presented.

In cases when floods generally occur in one specific season, data can be grouped in seasons (series of seasonal maxima) and analyzed separately. Distributions for particular seasons are then combined to yield the compound distribution of annual maxima (compound POT method). This is particularly useful for catchments in which floods are generated from two different processes, e.g. from heavy rains and from snow melt.

Large floods in Europe

Les grandes crues en Europe

V.Al.Stanescu, M. Matreata

1 Introduction

The assessment of the peak discharges during the old historical floods is very difficult to make and there is only little information on such data. Some information concerning the reconstructed maximum discharges of the outstanding historical floods is available and refers to the Main river (Germany) in 1342, 1451, 1546, 1682 and 1784 (Schiller, 1987), the Isère (France) in 1651, 1740 and 1800, the Seine (France) in 1658 (Rodier et Roche, 1984) and the Mulde (Germany) in 1573. More information of a more reliable nature on the large floods in Europe has been available since the nineteenth century. Selected data concerning very large floods which occurred before this century are presented in Table 1.

Knowledge of very large floods offers to hydrologists as well as to policy and decision makers very valuable information enabling (i) the identification of the zones with hazards and the evaluation of the hazard, (ii) the carrying out of a spatial-temporal statistic analysis of the vulnerability to floods and the risk, (iii) the establishment of monitoring systems for prediction, forecasting and warning, (iv) the planning and the building of the long-term prevention measures and infrastructures, (v) the preparation of the institutional and individual measures to be taken in due time with promptness, (vi) the education of the people on the perception and correct understanding at risk and (vii) the development of research in the domains of the natural sciences, of the psychology of the communities coping with these events and their effects on ecology and society. The transfer between countries of knowledge concerning outstanding floods enables better understanding of the causes and processes of flood formation as well as to validation of the synthetic statistical values of their hydrological characteristics.

2 Data sources

This work is based upon (i) the information on the maximum discharges and the rainfalls causing floods published in the international catalogues (Stanescu et Kikkawa, 1976), (Rodier et Roche, 1982), (ii) the hydrological monographs (***, 1898), (***, 1958), (Pardé, 1961), (Stanescu, 1967), (***, 1986), (Spreafico et Stadler, 1988), (Spreafico et Aschwanden, 1991), (Engel et al, 1994), (iii) the hydrological yearbooks of Romania, Austria, Yugoslavia and Hungary. Also, more than 30 papers were used containing information concerning the description of the characteristics, the causes and the formation of large floods which occurred in the last century in Europe.

3 Outstanding floods in large basins

3.1 The Rhine river floods

The flood of December 1993 - January 1994 originated over a wide-spread area, where long lasting abundant rainfalls occurred during two periods of various durations (Engel et al, 1994).

Table 1 : Large floods in Europe, before XXth Century
Table 1 : Grandes crues en Europe, avant le XXth siècle

Country	Basin	River	Station	Basin Area (km ²)	Qmax (m ³ /s)	Date
Austria	Danube	Danube	Wien	101700	14000	.08.1501
					11800	01.11.1787
		Inn	Innsbrück	5794	1350	17.06.1855
					1210	19.06.1871
Traun	Wells	3499	1660	13.09.1899		
Czech R.	Elbe	Elbe	Decin	51100	5600	30.03.1845
Germany	Rhine	Rhine	Maxau	50196	4620	28.12.1882
			Kaub	104000	7400	01.05.1883
		Neckar	Heidelberg	13809	4000	30.10.1824
					3000	28.12.1882
		Mosel	Cochem	27100	3640	28.11.1882
		Main	Frankfurt	24765	2450	27.11.1882
			Würzburg	14031	3300	22.07.1342
		2600			09.02.1784	
	2300	24.01.1546				
	Weser	Weser	Intschede	37790	4650	21.01.1841
	Elbe	Elbe	Dresden	53100	4350	06.09.1890
	Mulde	Golzeen	5440	2200	14.08.1573	
	Danube	Danube	Hofkirchen	47496	4470	31.03.1845
France	Rhône	Rhône	Lyon	20300	4500	31.05.1856
			Beaucaire	96500	10000	31.05.1856
		Drome	Livron	1640	1300	09.1842
		Durance	Pt. Mirabeau	11900	5100	25.10.1882
		Isère	Grenoble	5720	2500	11.11.1651
					2000	20.12.1740
	Loire	Loire	Gien	35900	8500	02.06.1856
		Allier	Moulin	13000	7000	.11.1790
	Garonne	Garonne	Agen	34900	8500	.06.1875
	Seine	Seine	Paris	44300	2500	27.02.1658
Italy	Adige	Adige	Trento	9770	2500	17.09.1882
	Po	Ticino	Miorina	6600	5000	02.10.1868
Portugal	Tejo	Tejo	Vila Velha	59170	12000	07.12.1876
Romania	Danube	Danube	Orsova	575000	15900	17.04.1895
					15400	07.06.1897
Russia	Neman	Neman	Smolinikai	81200	6820	30.04.1829
Spain	Guadiana	Guadiana	Badajos	48515	10000	07.12.1877
	Ebro	Ebro	Zaragoza	40430	3800	18.02.1889
Sweden	Dalaven	Dalaven	Norslund	25300	2640	01.06.1860
Switzerland	Rhine	Rhine	Basel	35925	5700	13.06.1876
	Po	Ticino	Bellinzona	1515	2500	28.09.1868
United Kingdom	Dee	Dee	Cairnton Woodend	1370	1900	.08.1829
	Thyne	Thyne	Hexam	3900	1970	.1771
Yugoslavia	Sava	Drina	Visegrad	11000	10000	.1896

During the first period (7-18 December 1993) the maximum amount of precipitation exceeded 120 mm, the most important values, averaged over the subbasins, being recorded in the Sauer river basin (111 mm), Saar and lower Mosel (99-105 mm), Neckar (88 mm), Nahre (87 mm) and Ruhr (99 mm) river catchments. These rainfalls formed a first flood and contributed to the increase of soil moisture.

During the second period (19-20 December 1993) the maximum values exceeded 120 mm, the average amounts over the subbasins being of 68 mm (Neckar), 78 mm (Saar) and 63 mm (Main).

The frequency of the maximum rainfalls during this period was according to Ebel and Engel (1995) of 1/100 - 1/200 years in the Neckar, Main and Mosel river basins. Other factors which favoured flood

formation were the rise in the air temperature up to more than 10° C, at mean elevations, which brought about intense melting of the existing snow and quasi-simultaneous occurrence of the peak discharges of the main tributaries, namely the Neckar, Main and Mosel.

The flood of January 1995 originated due to two wide-spread rainfall events (Ebel et Engel, 1996) namely on 9-10 January and on 21-30 January, which had maximum values of 140-160 mm and on more than 250 mm in the middle and lower parts of the basin (Fink et al, 1996). This flood was formed mainly downstream of the confluence with the Neckar river. The contribution of the Main river by contrast with the 1993/94 flood and the tributaries downstream of the mouth of the Mosel being very significant. Neither the 1993/94 nor the 1995 flood has originated in the Alps (Engel, 1996 a).

The Meuse, the lowest tributary of the Rhine, had a peak discharge of 2900 m³/s, very close to that of the 1993/94 flood (3120 m³/s), (Chbab, 1996), (Parmet et Burgdorffer, 1996).

Table 2 shows the maximum discharges of the 1993/94, 1995 floods as well as their return periods while Figure 1 gives the superimposed hydrographs of 1925/26 (the largest one), 1993/94 and while 1995 floods of the Rhine at Köln and Mosel River at Cochem.

Table 2 : Rhine River Basin: characteristics of 1993/94 and 1995 floods
Table 2 : Bassin du Rhin : caractéristiques des crues de 1993-94 et 1995

River	Station	Area (km ²)	Qmax (m ³ /s)		Return period (years)	
			1993/1994	1995	1993/1994	1995
Rhine	Rheinfelden	16000	1770	3550	<1	20
Rhine	Maxau	50343	3020	4080	2.5	15
Neckar	Rockenau	12676	2690	1240	50	2
Rhine	Worms	68936	4760	4290	10	7-5
Main	Frankfurt	24764	1395	1890	9	60
Nahe	Grolheim	4013	1150	1045	100	-
Rhine	Kaub	103729	6500	6400	40	35-20
Lahn	Kalkofen	5304	754	731	15-20	15-20
Mosel	Cochem	27088	4170	3550	80	25
Rhein	Andernach	139795	10500	10200	65	40-30
Rhein	Koln		10800	10940	65	70
Ruhr	Hattingen	4532	508	598	30	20
Rhine	Rees	159683	11000	11600	80	90
Meuse	Borgharen	21000	3120	2870	125	65
Rhine	Lobith	160000	11100	12060	80	80

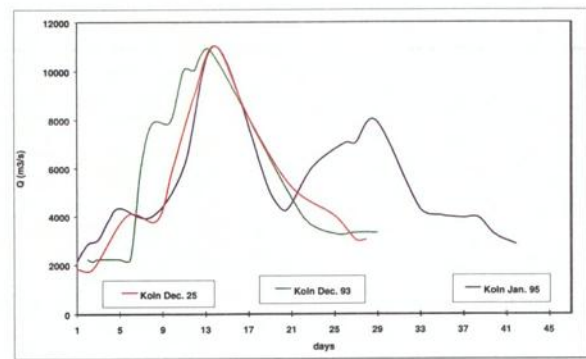
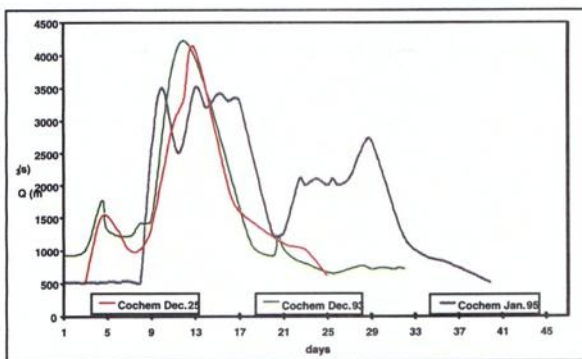

Figure 1 : Rhine and Mosel flood hydrographs in 1925/26, 1993/94 and 1995 (after Engel, 1996 b)
Figure 1 : Hydrogrammes de crues du Rhin et de la Moselle en 1925/26, 1993/94 et 1995

3.2 The Danube river floods

The Danube river basin has an area of about 807000 km² and therefore large floods of rare frequencies which would cover the entire surface of the catchment are less frequent. That is why the floods which occurred in the upper Danube and those produced in the middle reaches are presented separately.

The upper basin flood of 12 March-6 April 1988 occurred as a result of two rainfall events (Deisenhofer et Schiller, 1989). The first one (10-17 March) having average values of 50-100 mm over the basin combined with the melting of the snow which had a water equivalent varying between 30-100 mm, resulted in a first wave with a peak occurring on 18-19 March. The second one (20-28 March) had values of 60-100 mm which under the circumstances of a “wet paved” soil led to the second, higher peak occurring on 26-28 March. In Table 3 the maximum discharges of the Danube and its main tributaries and their return periods are presented.

Table 3 : Maximum discharges and their frequencies of the March 1988 flood in Germany

Table 3 : Débits maximaux, et leurs fréquences, pour les crues de mars 1988 en Allemagne

River	Station	Area (km ²)	Q _{max} (m ³ /s)	Return period (years)
Danube	Neu Ulm	7578	760	5
Danube	Donauwörth	15037	1110	20
Danube	Ingolstadt	20001	1360	6
Danube	Oberndorf	26446	1620	10
Naab	Hetzenhofen	5426	600	20
Danube	Schwabelweis	35399	2600	20-30
Danube	Hofkirchen	47496	3020	15
Inn	Passau-Ingling	26081	1800	10

The floods in the middle sector of the Danube are caused by spring-summer high waters occurring both on the Danube upper reaches and in the main tributaries, namely the Drava, Sava, Tisa and Velika Morava which along a “confluence sector” of only about 300 km, come into the main course and contribute to a large rise in Danube discharges. An analysis of the coincidence of high waters of the Danube and its main tributaries revealed correlation coefficients between the peak discharges of the Danube and Sava and Tisa rivers of $r=0.75$ and $r=0.55$ respectively, (Stanescu, 1967). This timing of the peaks of these tributaries result in the increase of the peak discharges of the middle Danube floods between the confluence with Drava river (Mohacs station) and the confluence with Velika Morava (Orsova station).

The floods in the middle sector of the Danube originate in wide-spread rainfalls combined with snowmelt water, mainly from the Alps and from the mountainous zones of the tributaries. Figure 2 presents some significant flood hydrographs at both the upstream and downstream ends of the “confluence sector” (Mohacs and Orsova station, respectively) as well as the hydrographs of the main tributaries. The largest floods occurred on this sector in 1895 (15900 m³/s) and in 1897 (15400 m³/s) with a return period of about 50 years.

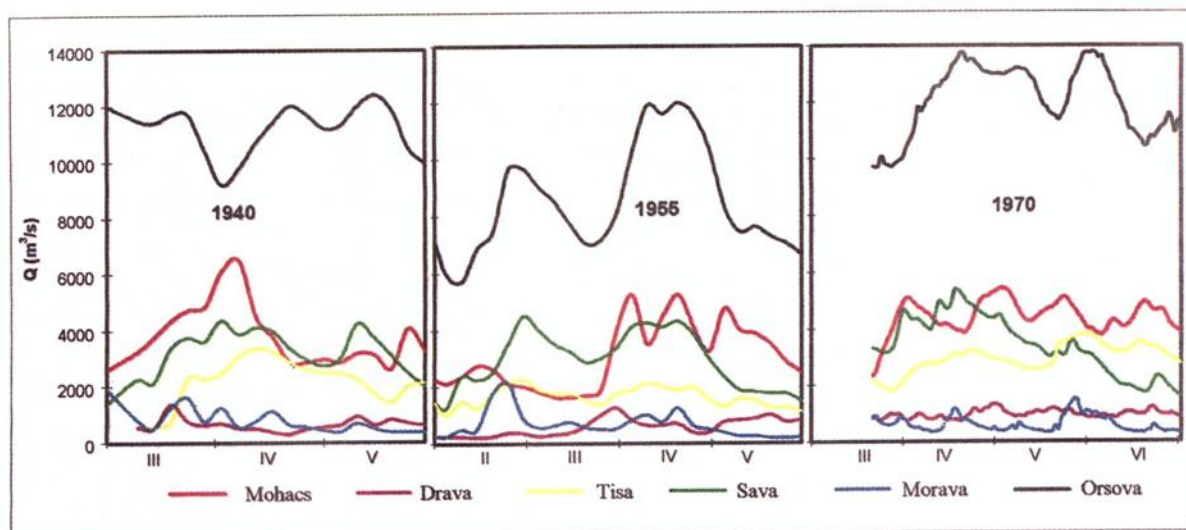

Figure 2 : Danube (Mohacs and Orsova stations) and its tributaries : flood hydrographs
Figure 2 : Hydrogrammes de crue du Danube (stations Mohacs et Orsova) et de ses affluents

4 Outstanding floods in medium size basins

The flood of 10-15 May 1970 in the river basins of Transylvania (Romania) (Stanescu et al, 1995) covered an area of about 50000 km² comprising the Mures, Somes and Viseu catchments. This flood was due to heavy precipitation falling over a period of three days and having average values of 90-100 mm and maximum ones exceeding 150-200 mm. The previously wet soil as well as the melting of the snowpack in the mountain areas contributed substantially to the amplification of the rainfall effect. Table 4 gives the maximum discharges at representative stations are presented (Stanescu et al, 1972).

Table 4 : Maximum discharges and their frequencies for the May 1970 flood in Romania
Table 4 : Débits maximaux, et leurs fréquences, en mai 1970 en Roumanie

River	Station	Area (km ²)	Q _{max} (m ³ /s)	Return period (years)
Somes	Nepos	1138	850	70
Somes	Dej	8824	2300	90
Somes	Satu Mare	15000	3340	125
Mures	Glodeni	3756	1210	200
Mures	Alba Iulia	17964	2450	100
Viseu	Bistra	1555	1072	83

The flood of 17 January 1993 in the Tay river basin (United Kingdom) resulted from passage of two vigorous weather systems bringing heavy rainfalls of more than 60 mm and a significant raise in the air temperature by 4-6° C (Black et Anderson, 1994) which provoked a rapid melting of an extensive snowpack up to the 400 m elevation. The flood peaks were increased by the coincidence of the maximum discharges of the main tributaries. A peak flow of 2268 m³/s with a 70-80 year return period was recorded at the outlet station Balathie (basin area F=4587km²).

The flood of 10-12 December 1994 in the Strathclyde region (United Kingdom) resulted from abundant rainfall which had maximum values in over two days ranging from 130 to 220 mm. At the outlet of the Clyde river basin (area 1903 km²) the maximum discharge was 1300 m³/s with a return period of 20 years (Black et Benett, 1995). Due to the high rainfall intensities, the flood had

exceptional peaks even in the small basins. Thus in the Fallock river basin ($F=80 \text{ km}^2$) the peak discharge was $176 \text{ m}^3/\text{s}$.

The greatest historical floods in United Kingdom were specifically the Findhorn flood of 17 August 1970 with a flow of $2410 \text{ m}^3/\text{s}$ at Forres ($F=781.9 \text{ km}^2$) and the 1771 Tyne river flood producing an estimated flow of $3900 \text{ m}^3/\text{s}$ at Hexham ($F=1970 \text{ km}^2$). These discharges provide an idea of the flood potential in United Kingdom catchments.

The flood of 4-5 November 1994 in the Po river basin (Italy) resulted from intense 3-day-rainfall with amounts ranging between 280 mm in the southern part, 315 mm in the west and 550 mm in the north of the catchment. Table 5 shows the maximum discharges and their return period (Marchi et al, 1995).

Table 5 : Po River Basin : Maximum discharges and their frequencies during the November 1994 flood

Table 5 : Le Bassin du Po : débits maximaux, et leurs fréquences, pour les crues de novembre 1994

River	Station	Area (km^2)	Q_{\max} (m^3/s)	Return period (years)
Sesia	Outlet	2300	3000	80-100
Tanaro	Outlet	8000	3500	80-100
Po	Ponte Becca	36800	11300	30-40
Po	Pontelagoscuro	70000	9000	15-20

The flood in 4 November 1966 in the Toscana region (Italy) was provoked by intense 25-hours precipitation which fell over a large area of more than 10000 km^2 which primarily affected the Arno and Ombrone river basins. The maximum amounts exceeded 400 mm with the intensities of 30-50 mm/hour. The average rainfall over the subbasins was estimated to range between 110-189 mm (Bendini, 1967). This flood was the greatest in four hundred years. Table 6 lists the peak discharges recorded at several stations.

Table 6 : Maximum discharges recorded during the November flood in the Arno and Ombrone rivers

Table 6 : Débits maximaux de la crue de novembre (1966) sur l'Arno et l'Ombrone

River	Station	$F(\text{km}^2)$	$Q_{\max}(\text{m}^3/\text{s})$	$q_{\max}(\text{l/s km}^2)$
Arno	Trebbiano	738	2250	3050
Ambra	Molino di Montarzi	158	726	4590
Arno	Montevarchi	2676	2580	950
Sieve	Fornacina	831	1340	1610
Arno	Nave di Rosana	4083	3540	870
Merse (Ombrone)	Ornate	483	934	1930
Forma (Ombrone)	Ponte di Tornarella	70	464	6630
Ombrone	Sasso d'Ombrone	2657	3110	1170

The flood of 5-7 November 1994 in the Alpes-Cote d'Azur region (France) resulted from heavy 3-day-rainfalls which exceeded 100-150 mm over most of the area. As a result of the high intensities, large flood peaks were recorded both on Durance river (the main course of the region) where the maximum discharge was of $3300 \text{ m}^3/\text{s}$ and in its tributaries : the Verdon at Vinion station ($F=2200 \text{ km}^2$, $Q_{\max}=1000 \text{ m}^3/\text{s}$), Brech, Bleone and Duyes. The flood was very intense on the Var river, the recorded peak at the outlet ($F=2870 \text{ km}^2$) was $3800 \text{ m}^3/\text{s}$ with a return period of about 100 years (***, 1995). The Rhone river, which has its mouths in this region, reached a maximum discharge of $9700 \text{ m}^3/\text{s}$, downstream of Tarascon, a value which is a little less than the historical value ($Q_{\max}=10000 \text{ m}^3/\text{s}$) recorded at Beaucaire station ($F=96500 \text{ km}^2$).

5 Flash floods

In Europe the prevalent zones for flash floods are located in areas influenced by Mediterranean cyclones (Cote d'Azur, East Pyrenees, Cevennes, Corse (France), north-western areas of Italy and Catalonia (Spain). Severe flash floods also occur in small catchments where an orographic rise take place of the cold air masses of tropical origin. These types of air mass have a marked instability manifested by upward movements resulting in heavy, very intense rains. Peak discharges of the highest flash floods, recorded in Europe are presented in Table 7 which is based on information taken from many published papers (Pardé, 1961), (Stanescu et al, 1976), (Stanescu et al, 1995), (Gilard and Mesnil, 1994), (Loye-Pilot et Pasquier, 1994), (Benech, 1993), (***, 1995), (Davy, 1989), (Hemain et Dourlens, 1989), (Bonvin, 1994).

Table 7 : Selected outstanding flash floods in Europe

Table 7 : Sélection de crues rapides exceptionnelles en Europe

Country	River	Station (location)	Area (km ²)	Q _{max} (m ³ /s)	Date	P (mm)	D	T (years)
France	Caderaux	Nîmes	42	1600	03.10.88	300	6h	200
	Ouveze	Vaison la Rom.	580	1000	22.09.92	140	2h	1000
	Tech	Ceret	483	3500	17.10.40	360	6h	100
	Reart	Mas Palegry	137	1100	26.09.92	216	4h	100
	Solenzara	Canniciu	99.7	1575	31.10.93	794	24h	200
	Fiumicicoli	Outlet	97	1300	31.10.93	794	24h	300
Germany	Wolf	Outlet	14	225	3.08.51			
	Muglitz	Outlet	27	500	8.07.27	100	25'	-
	Gottleuba	Outlet	26.3	500	8.07.27	100	25'	-
United Kingdom	Farley	Lynmouth	17	286	15.08.52			
Italy	Orba	Orticlieto	141	2200	13.08.35	389	8h	-
	Ambra	Montorzi	158	726	04.11.66	437	24h	100
	Farma	Torniella	70	464	04.11.66	339	24h	100
	Magra	Calamazza	939	3480	15.10.60	205	24h	
	Oreto	Parco	75.6	352	26.10.51	147	6h	30
Romania	Cobia	Raciu	19	180	26.06.79	200	2h	200
	Potop	G. Foji	196	875	26.06.79	250	4h	200
	Mâzgana	Outlet	17	209	3.07.75	150	4h	100

6 Regionalisation of the large floods in Europe

From all the above mentioned sources a catalogue of the very large floods of Europe has been compiled. This catalogue contains maximum discharges and data on when they occurred at 540 stations (locations) on European rivers. The catchement areas of the selected stations (locations) rang between a couple of square kilometres to more than hundred thousand (Table 8).

Table 8 : Distribution of the basin areas of the selected locations

Table 8 : Distribution des surfaces de bassins sélectionnés

Area (km ²)	< 10	10+50	51+100	101+500	501+2000	2001+5000	5001+10000	>10000
Number of locations	10	43	44	129	114	75	50	75

Based upon the data from the selected stations, the curves $q_{\max} = f(F)$, q_{\max} - maximum specific discharges, have been drawn for the countries where data were available. An example for France is given in Figure 3 and the enveloping curves drawn for each country are superimposed in Figure 4.

Mention is made that most of the selected peak discharges have occurrence frequencies exceeding 1/20+1/50 years.

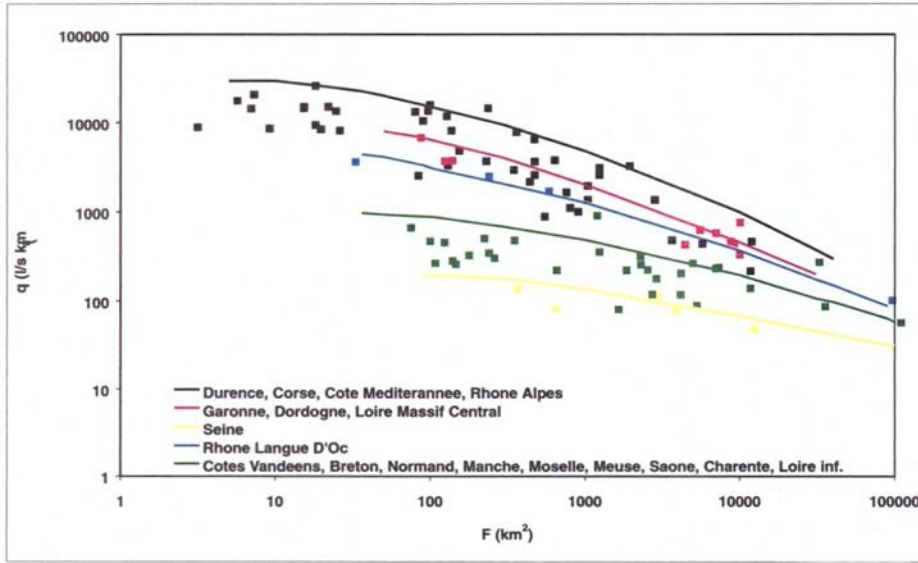

Figure 3 : Regionalization of large floods recorded in France
 Figure 3 : Régionalisation de grandes crues enregistrées en France

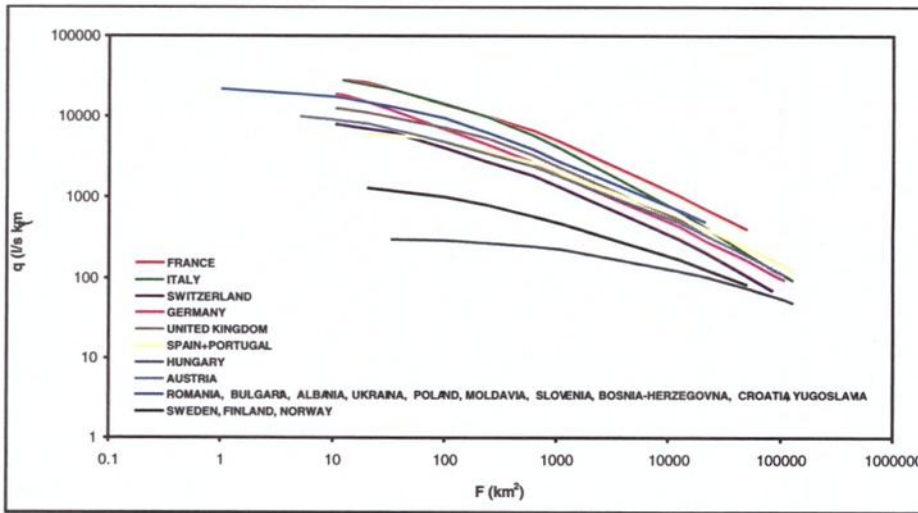

Figure 4 : Enveloping curves of large floods
 Figure 4 : Courbes enveloppes de grandes crues

7 Conclusions

This work is only a first approach in studying large floods in Europe. It is desirable to develop it within the framework of a European project, especially as the old catalogues do not contain the outstanding floods which have occurred during the last two decades. The occurrence of these floods has given rise to a lot of questions (Savenije, 1996) among which the following can be mentioned : (i) is there an increase in flood frequency ? and (ii) is the more severe character of the recent floods in Europe a result of human or climate change ? To answer to these problems, new research should be undertaken.

A new Modified Rational Method

La nouvelle méthode rationnelle modifiée

J. Ferrer and L. Ardiles

1 Introduction

The use of hydrometeorological methods in design flood estimation is normal practice both in the case of the Probable Maximum Flood (PMF), and situations where a statistical approach associated with a specific return period is adopted. In this second approach, which is normally used in Spain for design flood definition, the absence of sufficient gauging data leads to the frequent use of hydrometeorological methods which utilise the more abundant rainfall data.

In the latter case, the relationship between the return period associated with the rainfall and the discharge obtained is not clear and could be regarded as heuristic, so the use of complex rainfall-runoff transformation models is not very helpful. This explains why simple methods such as GRADEX (Giullot and Duband, 1967), more recently AGREGEE (Margoum et al., 1994) or versions of the rational method (Témez, 1991), have been successful.

The threefold aim of this article is : a) to review the main characteristics, advantages and drawbacks of the rational formula, b) to describe the formulation of the Modified Rational Method (MRM), included in the Spanish drainage standards (MOPU, 1990), and c) to make certain comparisons with other methods which are included in the FRIEND-AMHY Project.

2 The Rational Method

The rational formula for design flood calculation dates back to the turn of the last century, there being no general consensus among authors as to the origins of its conception. In spite of its limitations, it is possibly as close as one can get to the basic law sought by surface hydrology during the second half of the XIX Century and the beginning of the XX Century.

The main advantage of this formula, lies in the fact that it manages to combine the simplicity of formulation and the choice of the basic variables which play a part in the phenomenon: catchment area, rain fall amount and the characteristic time of the basin.

In spite of both the strong criticisms levelled at it in scientific and university circles and the spectacular developments made in Hydroinformatic, the rational formula is possibly still the most widely used method in engineering practice (Pilgrim, 1986), for dealing with small and medium-sized basins, particularly in the case of urban basins (UNESCO, 1977), when only the peak discharge has to be estimated.

The extensive range of rational methods (RM) can, like the unit hydrograph method (Sherman, 1932), be included among the black box linear-type rainfall-runoff aggregate models. The scope of applicability for these aggregate models is limited to basins which, depending on different authors, range from 500 to 3,000 Km², according to the heterogeneity of the rainfall and the runoff characteristics.

As part of the all-encompassing concept of the rational formula, the MRM endeavours to overcome the main objections that are levelled at this type of method:

- for average and low discharges, a lack of relationship between the maximum rainfall and the maximum discharges.
- the hypothesis of constant net rainfall intensity for an interval equivalent to the concentration time.
- a runoff coefficient that is constant and irrespective of the rainfall magnitude.
- lack of agreement with experimental data.

3 The Modified Rational Method (MRM)

3.1 Characteristics

The MRM (Témez, 1991) is designed as a method for transfer between the maximum daily rainfall frequency distribution (input) and the peak discharge frequency distribution (output). The approach in this method, is thus aimed at estimating peak discharges with a specific return period, and it has the following characteristics:

- standard nature for the Spanish highway drainage design (MOPU, 1990).
- scope of application extended to basins ranging from 500 to 3,000 Km², by including empirical coefficients.
- ease of application in basins with no gauging records.
- experimental comparison of gauging stations.
- original formulation of the runoff coefficient (C), based on the Soil Conservation Service (SCS, 1972) runoff laws.

3.2 Rational formula

For an ideal shower of indefinite duration, and constant net rainfall intensity (E), the discharge generated (Q) would grow until it reached a balance, at which point the input and output flows of water in a basin with a surface area A, would be the same:

$$Q = E A \quad (1)$$

At that time, the runoff coefficient (C) will be the relationship between the net rainfall (E) and the total rainfall (I) intensities :

$$\frac{E}{I} = C < 1 \quad (2)$$

The maximum discharge will be that of the balance, producing the classic rational formula:

$$Q = E A = C I A \quad (3)$$

which using the usual units for Q (m³/s), I (mm/h) and A (Km²) yields:

$$Q = \frac{C I A}{3.6} \quad (4)$$

The time taken to bring about a balance between the output hydrograph and a net constant hyetograph, is the same as the traditional concentration time (T_c), defined as that which elapses from the end of the net hyetograph up to the end of the surface hydrograph.

For real showers, the interval that generates the maximum peak discharge tends to be a period of T_c duration which provides the maximum average value of net rainfall (C I). Accepting the simplification that this interval is the same as the maximum average value of I, the calculation of peak discharges in the rational method is reduced to that of the maximum values of the **average** intensity (I) in the intervals of T_c duration and the value of the runoff coefficient (C) that can be expected for those same intervals. However, applying equation (4) for this interval would lead to a loss of precision, in the sense that there would be a marked increase in rainfall variations for the period.

This is the classic disadvantage of the rational method with respect to the basin size, given that the constant net rainfall hypothesis is moving farther away from the real situation and underestimating discharges, when the value of T_c increases. This drawback, which is very severe when one attempts to analyse real showers, can be tackled in a statistical context for return periods, through the inclusion of an empirical uniformity factor K, which affects equation (4).

A unit value of K , responds to the ideal hypothesis of the uniform distribution implicit in the rational method, whereas with the hypothesis of the triangular unit hydrograph, an instant rainfall impulse would lead to a value of $K = 2$. The value of K varies from one episode to another, but its average value in a specific basin, basically depends on its T_c and, on a secondary level, on the characteristics of the rainfall regime. An empirical analysis carried out at different Spanish gauging stations, has allowed the characterisation of the dependence of K upon $T_c(h)$, giving rise to the following equation :

$$K = 1 + \frac{T_c^{1,25}}{T_c^{1,25} + 14} \quad (5)$$

Formula (4) is modified by this factor, and the following equation is given :

$$Q = \frac{CIA}{3,6} K \quad (6)$$

The inclusion of this factor, makes it possible to extend the MRM's field of application as far as the limits of other aggregate methods.

3.3 Runoff coefficients

The runoff coefficient (C) proposed in the MRM, is based upon the formulation of the Soil Conservation Service (SCS, 1972), which defines the relationship between rainfall and runoff in the following way :

$$\frac{E}{P_0} = 0 \text{ if } \frac{P}{P_0} \leq 1 \text{ and } \frac{E}{P_0} = \frac{(P/P_0 - 1)^2}{P/P_0 + 4} \text{ if } \frac{P}{P_0} > 1 \quad (7)$$

The above formula assumes the existence of a runoff threshold (P_0), below which the accumulated rainfall (P) does not cause runoff. This value acts as an initial interception amount before evaluating the accumulated runoff (E) up to a given point in time.

The value of the P_0 parameter depends, for certain prior moisture conditions in the soil-vegetation complex, on the characteristics of the basin, as regards: a) the infiltration capacity, b) land use and agricultural activities and c) the ground slope. This dependence was quantified by the SCS after intensive research, tables being obtained which permit P_0 to be estimated for average moisture conditions. This possibility of estimating the parameter in the absence of data, is the main reason for explaining the extensive use of the above formula in real studies.

Taking (7), the instantaneous coefficient of runoff (C), at a particular point in time, up to which P has fallen and caused runoff E , the following expression can be obtained by derivation :

$$C = \frac{dE}{dP} = \frac{d(E/P_0)}{d(P/P_0)} = \frac{((P/P_0) - 1) \cdot ((P/P_0) + 9)}{((P/P_0) + 4)^2} \quad (8)$$

The above formula shows how C grows from 0 ($P < P_0$) until it reaches 1 asymptotically with great values of P . The application of RM requires the value of C in the interval of duration equal to T_c and a maximum average value of I , which by hypothesis is the interval that generates the maximum discharge. This value can be obtained from equation (8) if the value of P is known at that point in time.

However, this theoretical procedure for obtaining C , requires two empirical modifications if it is to be totally applicable :

a) As basic data, the MRM uses those for daily rainfall P_d , so it is necessary to establish a relationship between P_d and P . This relationship describes the relative position of the interval that generates the maximum discharge within the daily pluviograph. The relationship adopted, checked with an analysis of numerous pluviographs, is the following :

$$(P)_{\text{Imax}} = 0.5 P_d \quad (9)$$

b) The basic RM hypothesis does not systematically hold for short return periods: the maximum discharge is not associated with the maximum intensity interval and duration T_c , because the precipitation would be entirely absorbed by the ground, given that it is lower than the runoff threshold. That is to say, in spite of the existence of runoff ($P_d > P_o$), the above formula would not react to it because $C = 0$, with $0.5 P_d < P_o$. This problem is approached by modifying equation (8) in the low values environment, causing it to separate from the axis $C = 0$ for $P_d = P_o$, later to be confused with the original curve (Fig. 1). The final equation proposed is as follows :

$$C = \frac{((P_d / P_o) - 1) * ((P_d / P_o) + 23)}{((P_d / P_o) + 11)^2} \quad (10)$$

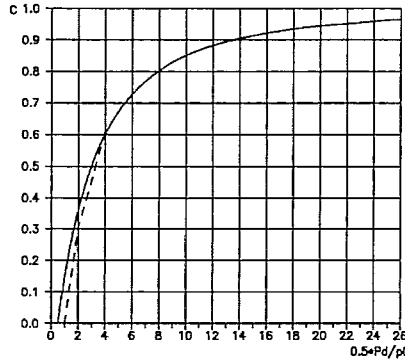

Figure 1 : Proposed runoff coefficient law.

Figure 1 : Loi proposée pour le coefficient d'écoulement

3.4 Other parameters

The basic formulation, which characterises the MRM described, making it different from the other methods in the rational family, can be seen in equations (5), (6) and (10). However, there are other basic parameters: T_c and I which, although they condition the results, can be estimated through a variety of procedures as a function of the geographical area of application and of the basin characteristics. The current Spanish standard (MOPU, 1990), proposes the following procedure :

The **concentration time** (T_c), has a direct effect on discharge estimation: a) the value of I is an average value in an interval whose duration is equal to T_c , b) the formulation used for parameter K , depends exclusively on T_c .

Given the proliferation of characteristic times and empirical formulae, it is advisable to take precaution to ensure that it is correctly used. In the absence of specific data, the MRM method proposes the estimation of $T_c(h)$ from the following expression :

$$T_c = 0.3 \left(\frac{L}{J^{1/4}} \right)^{0.76} \quad (11)$$

where L (km) and J (m/m) are the average length and average slope of the main channel. This equation is based upon an empirical estimation of the U.S. Corps of Engineers (US ARMY, 1957) for rural basins where channel flow is predominant.

Given the basically simple nature of the RM, it is not considered essential to include in it the estimation of T_c secondary factors such as land use, or to consider its variation with respect to the rainfall intensity.

The **intensity** I to be used in equation (6), is for an average value throughout the interval of duration t , equal to T_c and associated with a return period T . There are several formulae for describing $I(t, T)$, but they are generally equations of the following type :

$$I(t, T) = A(T) B(t) \quad (12)$$

The following formula is proposed for applying MRM in Spain :

$$I(t, T) = \frac{P_d(T)}{24} \left(\frac{I_l}{I_d} \right)^{\frac{28^{0.1} - t^{0.1}}{28^{0.1} - 1}} \quad (13)$$

where $P_d(T)$ is the daily rainfall (mm) associated with a return period T and I_l/I_d is the parameter, regardless of T , which describes the torrentiality of the rainfall regime by means of the quotient between the hourly intensity and the daily intensity ($I_d = P_d / 24$). This parameter is regionalised on a national scale and ranges from 8 in the Atlantic regions to 11 in the Spanish Mediterranean regions.

A frequency analysis is required, generally through the statistical modelling of annual maximum series (AMS) of daily rainfall, if $P_d(T)$ is to be obtained. Recent work carried out on a national level by Ferrer and Ardiles (1994), can be referred to. The areal value of $P_d(T)$ must be corrected to take into account the basin size, by means of an areal reduction factor (ARF), for which the following equation is proposed, using the logarithm to the base 10 of the surface A in Km^2 :

$$A R F = 1 - \frac{\log(A)}{15} \quad (14)$$

3.5 Empirical contrast

The MRM, as described, can be considered dependent upon P_o as the only parameter, given that simple equations are provided for the rest of the variables and parameters. However, as this parameter is a function of the prior moisture situation in the soil-vegetation complex, it will be necessary to define the prior **characteristic** moisture state of the basin in order to obtain the estimation value. In this sense, two types of situation exist:

- a) Basins with gauging records, in which the value of P_o can be obtained directly by calibration, looking for an acceptable agreement between the maximum discharge frequency distribution of the sample and that obtained through MRM. In this case, a short data series makes it possible to directly calibrate parameter P_o , and use it later in extrapolating for high return periods.
- b) Basins with no gauging records where an edaphological study of land use and slopes, is required in order to estimate the initial value of P_o , which must be corrected on the basis of the moisture characteristics. Relationships can be found in SCS (1972), which allow the values of P_o to be transformed as a function of the total amount of rain that has fallen in the 5 days prior to the event, so a **representative** statistical value of the rainfall has to be obtained.

The application of both procedures to a set of Spanish basins with gauging records, has made it possible to: a) compare the goodness of the MRM, and, b) obtain, on a national scale, a factor consistent with the prior moisture characteristic of the region, which affects the initial value of P_o and allows for the application of the method to basins without discharge data.

4 Comparison with distributed models

4.1 Comparison characteristics

The use of rainfall-runoff models in the estimation of floods associated with a particular return period, is a traditional method in the absence of gauging data (NERC, 1975). In this context, the design of a channel on the River Guadalhorce ($3,123 \text{ Km}^2$), is tackled using distributed modelling (CEDEX, 1992) of its basin ($3,123 \text{ Km}^2$). This model was described and the results compared with the MRM in Ferrer and Ardiles (1992); this work is summarised below.

4.2 Distributed modelling

The event distributed model HEC-1 (HEC, 1981) was adopted, representing the entire basin through 29 sub-basins and 16 reaches of river. The sub-basin runoff was modelled in the following way: a) the SCS production function, already dealt with in (7), based on parameter P_o , b) the synthetic unit hydrograph (UH) proposed as a function distribution in SCS (1972). The propagation of the reach was modelled with Puls (USBR, 1989) and Muskingum (US ARMY, 1960) hydrological methods, depending on the flood routine characteristics of the reach.

The above mentioned model was calibrated with the information available for the major floods that occurred on 14th-15th and 26th-27th November 1989 together with: a) edaphological information and land use, b) formula (11) for the estimation of the UH time characteristic, and, c) reach parameters obtained from the detailed hydraulic modelling undertaken: both in permanent regime with model HEC-2 (HEC, 1982) and transitory regime with model MIKE-11 (DHI, 1988).

4.3 Frequency analysis by hydrological simulation

The use of the above model in flood estimation for return periods, poses the difficulty of relating the probabilities associated with rainfall to the consequent discharges. This difficulty is basically due to:

- the considerable variation that exists between the net rainfall estimation parameters and the initial moisture. It has been assumed that a **representative** value of P_o for the moisture situation in autumn, makes it possible to establish an relationship between the rainfall and discharge return periods, an average of the parameters obtained in the two calibration events being adopted for each sub-basin.
- the simplifying hypotheses that have to be adopted when spatially and temporally defining the shower associated with T . The total quantity of rain in each sub-basin was obtained through statistical modelling of the AMS of P_o , using the "index flood" regional method, with the SQRT-ET max (Etoh et al., 1986) distribution function and adopting the ARF recommended in the MRM. The dimensional distributions recorded in the two events analysed, were adopted for the temporal distribution: 14th-15th and 26th-27th November 1989.

4.4 Analysis of results

The above distributed modelling results were compared with the MRM, in which the areal average of $P_o(T)$ and P_o , was used for the entire basin. The T_c adopted was a result of the reach travel times obtained in the distributed model. The results obtained with both methods are shown in Table 1. As can be seen, the MRM provides results that are halfway between those proposed by the distributed model and the two hypotheses adopted for temporal rain distribution.

Table 1 : Comparison between the distributed model and the MRM.

Table 1 : Comparaison entre le modèle distribué et la Méthode Rationnelle Modifiée

T (years)		2	5	10	25	50	100	200	500
HEC-1	14-15 Nov	264	849	1141	2269	3017	3944	4729	5924
	26-27 Nov	301	907	1548	2601	3588	4824	6089	7964
RATIONAL METHOD		393	997	1665	2482	3306	4294	5349	6952

The good performance of the MRM, when compared to more complex models, indicates that the rainfall-runoff phenomenon must be suitably described, according to the simplified hypotheses normally used in practical applications, as regards: a) equivalence between rainfall and discharge return periods, b) definition of the design shower on the basis of AMS modelling of P_o and a given temporal distribution.

5 Comparison with aggregate models

5.1 Characteristics of the comparison

Within the studies conducted as part of the FRIEND-AMHY Project, special interest has been devoted to the comparison of flood estimation methods making use of the availability of a common data base. A summary is provided below, of the work carried out by Ferrer and Ardiles (1995), in which a comparison is given of the results obtained from the MRM and AGREGEE methods applied to 7 basins in France. These basins, whose main characteristics are shown in Table 2, were selected on the basis of the following criteria: a) geographical situation, b) length of the rainfall and gauging series, and c) an analysis of the basic statistics of the annual maximum series (AMS).

Table 2 : Physiographical characteristics

Table 2 : Caractéristiques physiographiques

BASIN NAME	FLORAC	VPINTE	CORBES	SEILH	JEAN	NEZEL	RAMBER
S (km ²)	125	216	263	192	72	61	232

5.2 Application of MRM

The rainfall data required for application of the MRM are daily rainfall for different return periods and intensity-duration relationship. The daily rainfall quantiles were obtained by ML estimation of the parameters of an EV1 model for AMS, using the rainfall station considered to be representative of each basin. The intensity-duration relationship (13) used was based on an existing regional work carried out with the traditional Montana formula in order to estimate the parameter I_t/I_d .

The T_c was estimated with (11) and the parameter P_o was estimated manually in each basin, a good graphic agreement being sought between the quantiles of Q calculated and the AMS of discharges recorded, using Gringorten's plotting formula for the observed values. In the basins analysed, a small range of values (28-32 mm) for the P_o values were obtained.

5.3 Analysis of the results

The 100 and 500 year quantiles obtained by the MRM were compared with those obtained by CEMAGREF, applying the AGREGEE method, yielding differences of less than 20%, that do not normally increase with the return period. In general, the MRM tends to provide more conservative results. For each basin, a comparison (Fig. 2a and b) between both basins was made using two procedures:

- graphic comparison with the sample values using Gringorten's plotting formula
- comparison with a regional "index flood" statistical model of AMS, using the methodology proposed by Hosking et al. (1985) and selected in FRENED (1989).

Selection is not easy for the first procedure, because the series length is short, but, using visual criteria, the best method for each basin would be the one shown in Table 2a.

Table 2b shows a summary of the statistical method using 3 return periods, 10, 100 and 500 years, in which a comparison is made between the two methods, showing which of them causes less difference as regards absolute values.

In conclusion, although only a few basins were used, the results of the MRM generally proved to be more conservative, and the MRM has been shown to yield similar, or even better, results to the AGREGEE model.

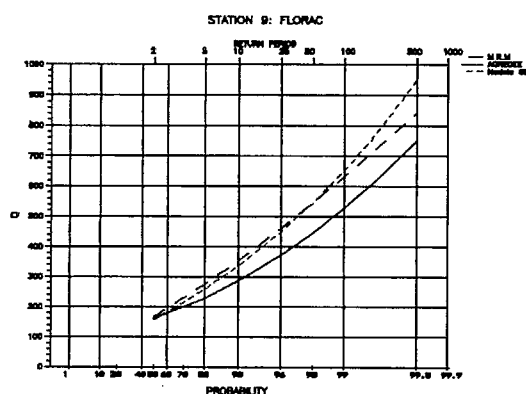
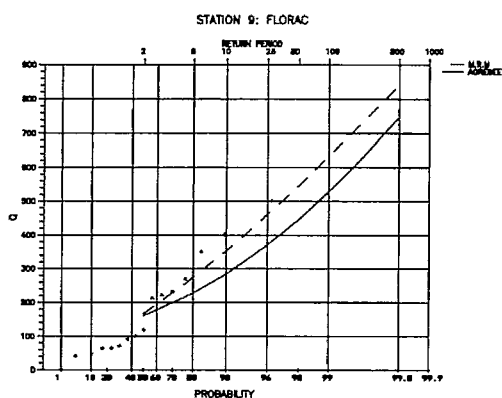

Figures 2a and b : Graphic comparison between the sample values and the MRM and AGREGEE (a) and between MRM and AGREGEE with the statistical modeling (b).

Figures 2a and b : Comparaison graphique entre les valeurs observées, la MRM et AGREGEE (a), ainsi qu'entre MRM, AGREGEE et le modèle de distribution statistique (b)

Tables 2a and b : Method with the best graphic adjustment (a) and Method with the least difference with respect to the statistical method (b).

Tables 2a and b : Méthode avec ajustement graphique optimal (a), et méthode avec minimisation des écarts selon le modèle de distribution statistique (b).

BASIN NAME		FLORAC	VPINTE	CORBES	SEILH	JEAN	NEZEL	RAMBER
a)	grafic adjustment	MRM	AGR	MRM	AGR	--	MRM	--
b)	T = 10	MRM	AGR	MRM	AGR	MRM	AGR	MRM
	T = 100	MRM	AGR	MRM	AGR	MRM	AGR	MRM
	T = 500	MRM	AGR	MRM	AGR	MRM	AGR	MRM

6 Conclusion

As a simple method for the estimation of peak discharges with a specific return period, the MRM can be applied practically in basins both with and without gauging records, and whose size is far above the upper limits associated with other traditional versions of the MR. Its simplicity makes it particularly suitable for use in regional hydrology and for its implementation in the SIG environments (Estrela and Quintas, 1996).

The FRIEND-AMHY Project has made it possible to verify its good performance in comparison with: a) rainfall-runoff distribution models, b) other simple models, and, c) regional statistical models.

The MRM presented, is characterised by a set of elements which require research work, in order to improve formulation as regards obtaining greater information from both experimental basins and theoretical work. Along these lines, a systematic analysis - using simulation techniques - of the response of the method's empirical coefficients in the face of different hypotheses regarding the temporal structure of rainfall and the rainfall-runoff transfer models.

Short conclusion

Brève conclusion

P. Versace

The papers reported in this chapter do not give a complete review of the researches on flood hydrology developed in the different countries. They essentially present a synthesis of the recent developments in the procedures analysed and compared in the main flood researches in FRIEND Groups.

The comparison among the different models here shown has not the goal to choose the "best" procedure, but to establish links among the results provided by the various procedures and to introduce modifications, if necessary, based on the experience matured by other nations.

Interesting results of these comparisons, as many of the papers here presented show, have been already obtained by working groups composed by researchers of different countries. The integration among different models is increasing. The applications in different hydrological environments show the flexibility of some proposed models. Some peculiar characteristics of one method have been successfully transferred to other ones. The performance of different models with the same data base has been compared.

However some aspects need further investigations. Physical phenomena that occur at slope and basin scale have to be more accurately considered in some procedures. Regional analysis and related techniques for parameter estimation need to be even more developed. Flood data base should be continuously increased with more recent flood events. It may be very useful to produce "event reports", which describe and analyse the largest floods. Greater attention has to be paid to flash floods, that occur in many countries involved in FRIEND project and often cause many victims. The international cooperation with joined research teams is well developed but it need to be even more encouraged. To this aim experimental basins with large and efficient data collection system would be precious. Finally detailed guidelines for the proposed procedures could allow application also out of the scientific community.

FRIEND project, as stated by the many interesting scientific and technical researches here reported, is achieving these issues and therefore it is necessary to go on with this effort.

ooooo

Les contributions de ce chapitre ne rendent évidemment pas entièrement compte de l'ensemble des recherches sur les crues développées dans les différents pays concernés. Elles présentent pour l'essentiel une synthèse de développements récents, analysés et comparés dans les principales recherches menées à l'intérieur des Groupes FRIEND.

Les comparaisons entre différents modèles, montrées ici, n'ont pas été faites dans l'intention d'en déduire la "meilleure" procédure, mais dans celle d'établir des liens entre les résultats provenant de diverses procédures, et d'éventuellement y introduire des modifications, si nécessaires et au vu des expériences menées dans d'autres pays. D'intéressants résultats de comparaisons, présentés dans nombre de contributions, ont déjà été obtenus dans des groupes de travail composés de chercheurs de différents pays. L'intégration entre divers modèles progresse. Des applications dans des environnements hydrologiques différents montrent l'adaptabilité de certains modèles proposés. Telle caractéristique particulière d'une méthode a pu être transférée dans une autre. Les performances de divers modèles ont pu être comparées à l'aide de jeux de données communs.

Cependant plusieurs aspects nécessitent des recherches complémentaires. Les processus physiques qui se produisent aux échelles des versants et des bassins doivent être plus précisément pris en compte dans certaines procédures. L'analyse régionale et les techniques liées d'estimations de paramètres doivent être développées. Les bases de données de crues devraient être continuellement complétées par les crues les plus récentes. Une attention plus soutenue doit être donnée aux crues éclair, qui se produisent dans beaucoup des pays impliqués dans le projet FRIEND, et qui font beaucoup de victimes. La coopération internationale avec des équipes de recherche communes est déjà bien développée, mais elle exige toujours d'être mieux encouragée. Pour tout cela, des bassins expérimentaux avec des systèmes de collectes de données largement développés et efficaces seraient un atout précieux. Enfin, des guides détaillés d'application des procédures proposées autoriseraient des usages extérieurs à la seule communauté scientifique.

Le projet FRIEND, comme cela est attesté ici par nombre d'intéressantes recherches scientifiques et techniques, est en train de servir ces enjeux. En conséquences, il est nécessaire de poursuivre les efforts dans cette direction.

References of chapter 4

Références bibliographiques du chapitre 4

- *** (1898) Die Hochwasserkatastrophe des Jahres 1897 in Österreich. Beihäge zur Hydrographie Österreichs. Hydrographischen Central-Bureau, Wien.
- *** (1958) : Les débits maximums des cours d'eau Suisses observés jusqu'en 1956. Publications de l'Inspection fédérale des travaux publics, Berne.
- *** (1986) : Die Donau und ihr Einzugsgebiet. Eine Hydrologische Monographie. UNESCO Regionale Zusammenarbeit der Donauländer, vol. 1-3, München.
- *** (1995) : Les crues du 5 au 7 Novembre 1994 en Provence Alpes Côte d'Azur. DIREN Rapport.
- Acreman, M.C. and Wiltshire, S.E. (1989). *The regions are dead: long live the regions. Methods of identifying and dispensing with regions for flood frequency analysis in the UK.* In L. Roald, K. Nordseth and K.A. Hassel (eds.) FRIENDS in Hydrology, IAHS Publ. N°187, pp.175-188.
- Bendini C. (1967) : La grande crue de 4 novembre 1966. Leningrad Symposium on Floods and their Computation. Proceedings, August 1967, vol. 2, 948-957.
- Benech C. (1993) : Les récentes crues dans les Pyrénées Orientales. Comparaison à l'Aignat de 1940. DDAF, Perpignan.
- Bernier, J. (1967). Sur la théorie du renouvellement et son application en hydrologie. Electricite de France, Hyd.67, no.10, 32pp.
- Beven, K. - Lamb, R. - Quinn, P. - Romanowicz, R. - Freer, J. (1995) : TOPMODEL. In: Singh, V.P. (ed): Computer Models of Watershed Hydrology. Water Resource Publications, (in print)
- Beven, K. (1993) : Prophecy, reality and uncertainty in distributed hydrological modelling. *Advances in Water resources* 16, 41-51.
- Beven, K. and Binley, A. (1992) : The future of distributed models: Model calibration and uncertainty prediction. *Hydrological Processes*, 6, 279-298.
- Beven, K.J., Calver, A. and Morris, E.M. (1987) : The Institute of Hydrology distributed model. Report 98, Institute of Hydrology, Wallingford, U.K.
- Binley, A.M. and Beven, K.J. (1991) : Physically-based modelling of catchment hydrology: a likelihood approach to reducing predictive uncertainty. In: Farmer, D.G. and Rycroft, M.J. (Eds.): *Computed Modelling in the Environmental Sciences*, Clarendon Press, Oxford, pp.75-88.
- Binley, A.M., Beven, K.J., Calver, A. and Watts, L.G. (1991) : Changing responses in hydrology: Assessing the uncertainty in physically based model predictions. *Water Resour. Res.*, 27(6), 1253-1261.
- Black A. R., Anderson J. L. (1995) : The great Tay Flood of January 1993. 1993 Yearbook Hydrological Data UK Series, Institute of Hydrology, Wallingford, 25-34.
- Black A. R., Benett A. M. (1995) : Regional Flooding in Strathclyde. December 1994. Hydrological Data UK : 1994 Yearbook, Institute of Hydrology, Wallingford, 29-34.
- Blazkova S., Beven K. (1994) : Using TOPMODEL for flood frequency predictions in the Czech Republic. CRES Techn. Report TR112/94, Lancaster University, UK.
- Blazková, Š. a Beven, K.J. (1995) : Frequency version of TOPMODEL as a tool for assessing the impact of climate variability on flow sources and flood peaks. *J.Hydrol. Hydromech.*, 43, 6, 392-411.
- Blazková, Š. and Beven, K. (1997) : Flood frequency prediction for data limited catchments in the Czech Republic using a stochastic rainfall model and TOPMODEL. *Journal of Hydrology* (accepted).
- Blazková, Š., Beven, K. and Franks, S (1996) : Investigation of the relative effects of climate change, deforestation, natural climatic variability and the uncertainty of flow predictions. Progress Report for EU, contract ERB-CIPD-CT94-0114 Impact of climate change on hydrological regimes and water resources in Europe.
- Bobee, B., Ashkar, F. (1988). The generalized method of moments applied to the logPearson 3 distribution. *J. Hydraul.Eng.,ASCE*, 114(8):899-909.
- Bonvin J. M. (1994) : Crues du 24 septembre 1993 en Valais. Grande Dixence SA, CH - 1950 Sion, Nimbus, no. 2.
- Brunet-Moret, Y. (1969). Etude de quelques lois statistiques utilisees en hydrologie Cah. ORSTOM, ser. Hydrol.

- Bubeníková, L., Chamas, V. and Jírovský, V. (1985) : Experimentální povodí Jizerské hory (Experimental basins in the Jizera Mountains). Report, Czech Hydromet. Inst., Prague.
- Burn, D. H. (1988). *Delineation of groups for regional flood frequency analysis*, J. Hydrol., 104, pp.345-361.
- Burn, D. H. (1990). Evaluation of regional flood frequency analysis with a region of influence approach, Water Resour. Res., 26(10), pp.2257-2265.
- Cannarozzo, M., D'Asaro, F. and Ferro, V. (1993). Valutazione delle piene in Sicilia. CNR-GNDICI, Palermo.
- Cao, C., Piga, E., Salis, M. and Sechi, G.M. (1991). Valutazione delle piene in Sardegna. CNR-GNDICI, Cagliari.
- CFGB (1994) : Design flood determination by the gradex method. 18° Congrès CIGB-ICOLD N°2, Nov., Bulletin du Comité Français des Grands Barrages, 96p.
- Chhab E. H. (1996) : How extreme were the 1995 flood waves on the rivers Rhine and Meuse ?. Paper accepted by the EGS Journal Physics and Chemistry of the Earth.
- Copertino, V. A. and Fiorentino, M. (1991). Valutazione delle piene in Puglia. CNR-GNDICI, Potenza.
- Cunnane C. (1973) : A particular comparison of annual maxima and partial duration series methods of flood frequency prediction. J. of Hydrology, 18, 257-271.
- Cunnane, C (1987). Review of statistical models for flood frequency estimation. Proceeding of the International Symposium on Flood Frequency and Risk Analyses, Baton Rouge, USA.
- Cunnane, C (1988). Methods and merits of regional flood frequency analysis. Journal of Hydrology, 100, pp. 269-290.
- Cunnane, C. (1988). Methods and merits of regional flood frequency analysis. J Hydrol., 100:269-290.
- Dalrymple, T. (1960). Flood frequency analysis. U.S. Geol. Surv. Water Supply Pap., 1543, pp.1-51.
- Davy L. (1989) : Une catastrophe naturelle : l'averse nîmoise du 3 octobre 1988 et ses conséquences hydrologiques. Hydrologie Continentale, vol. 4, no. 2, 75-92.
- Deisenhofer I., Schiller H. (1989) : Das Märzhochwasser 1988 in Bayern. Informationberichte. Bayerisches Landesamt für Wasserwirtschaft 3/89, München.
- Desurosne I., Oancea V., Oberlin G., Toma A., Hubert P. (1993) : Analyse comparative AGREGEE/PMP-PMF pour l'estimation des crues rares et extrêmes. Scientific Assembly of UGGI-AISH. Yokohama, poster, July, Hydrologie Continentale n°8-2.
- Desurosne, I., Oancea, V., Oberlin, G., Toma, A., Hubert, P. (1993). Analyse comparative AGREGEE / PMP-PMF en estimation des crues rares et extremes. Hydrol. Cont., vol. 8, no.2, pp.93-102.
- DHI, (1988). "MIKE-11": Microcomputer based Modelling system for River and Channels". Scientific Documentation. Danish Hydraulic Institute.
- Ebel U., Engel H. (1995) : The "Christmas floods" in Germany 1993/94. Bayerische Rück Special Issue 16.
- Ebel U., Engel H. (1996) : ... 13 month later. The January 1995 floods. Bayerische Rück Special Issue 17, München.
- Engel H. (1996 a) : The Flood Events 1993/1994 and 1995 in the Rhine River Basin. ASCE Congress, Anaheim, California, June 1996.
- Engel H. (1996 b) : Das Januarhochwasser 1995 im Rheingebiet. BfG Publ., Koblenz.
- Engel H., Busch N., Wilke K., Krahe P., Mendel H. G., Giebel H., Zieger C. (1994) : The 1993/94 flood in the Rhine Basin. BfG Publ., Report no. 0833, Koblenz.
- Estrela, T. y Quintas, L., (1996) : "El Sistema Integrado de Modelización Precipitación-Aportación. SIMPA. Revista Ingeniería Civil. In press.
- Etoh, T., Murota A., Nakanishi M., (1986) : "SQRT-Exponential Type Distribution of Maximum". Proceeding of International Symposium on Flood Frequency and Risk Analysis. Louisiana. May. 1986, pp 253-265.
- Ferrari E. (1996) : Some results from the comparison between AGREGEE and VAPI projects. Oral communication presented at the annual meeting of the AMHY group, topic IV floods. Paris, UNESCO, 16-18 October.
- Ferrari E., Versace P. and P. Villani (1990). Terzo livello di analisi regionale delle piene in Calabria. In: Previsione e prevenzione degli eventi idrologici estremi e loro controllo, Rapporto '88, Linea 1, GNDICI-CNR, Roma.
- Ferrari E., Versace, P. (1995) : Evaluation of index flood in Italy. Annual report FRIEND-AMHY n°5, UNESCO, Annual meeting FRIEND-AMHY topic IV (floods), Thessaloniki 25-27 sept. 1995.
- Ferrari, E. (1994). Regional rainfall and flood frequency analysis in Italy, International Conference on Developments in Hydrology of Mountainous Areas, UNESCO-AMHY FRIEND Annual Conference, 12-16 September, Stara Lesna, Slovakia.
- Ferrer F.J. and Ardiles, L., (1994) : Frequency Analysis of Daily Rainfall Annual Maximum Series in Spain. International Developments in Hydrology of Mountainous Areas, Stara Lesna, Slovakia, September 1994.

- Ferrer J. and Ardiles L., (1992) : "Frequency Analysis of Floods using Hydrometeorological Methods: Comparison in Guadalhorce Basin".
- Ferrer J. and Ardiles L., (1993) : "Maximum Discharge Analysis of The French AMHY Data using the Modified Rational Method". Séminaire International Annuel du Grupe AMHY de FRIEND, Madrid 1993.
- Ferrer J., Ardiles L. (1995) : Estimation of peak discharges : comparison of the results between Modified Rational Method (MRM) and the AGREGEE Method. Annual report FRIEND-AMHY n°5, UNESCO, Annual meeting FRIEND-AMHY topic IV (floods), Thessaloniki 25-27 sept. 1995.
- Ferrer, J. and Ardiles, L., (1995) : "Estimation of peak discharges. Comparison of the results between Modified Rational Method (MRM) and the Agregée Method". Séminaire International Annuel du Grupe AMHY-FRIEND, Thessaloniki.
- Fink A., Ulbrich U., Engel H. (1996) : Aspects of the January 1995 flood in Germany. *Weather* vol. 51, no. 2.
- Fiorentino, M., Gabriele, S., Rossi, F. and Versace, P. (1987a). Hierarchical approach for regional flood frequency analysis, in V. P. Singh (ed.), *Regional Flood Frequency Analysis*, pp. 35-49, D. Reidel, Dordrecht (NE).
- Fiorentino, M., Gabriele, S., Rossi, F. and Versace, P. (1987b). Regional flood frequency analysis using the two component extreme value distribution. A key reference abstract. *Excerpta*, vol. 2, pp.39-50.
- Fisher, J.I. and Beven, K.J. (1994) : Application of TOPMODEL and Bayesian uncertainty estimation framework to Rimbaud catchment to investigate the consequences of desertification. Final Report. *Ecosystem studies: Modelling the effects of desertification in Mediterranean regions*. Project of European Community EC DG X11.
- Frances F., Salas J. D., Boes D. C. (1994) : Flood frequency analysis with systematic and historical or paleoflood data based on the two-parameter general extreme value models. *Water Res. Res.*, Vol. 30, n°6, 1653-1644, June.
- Freer, J., Beven, K. and Ambroise, B. (1995) : Bayesian estimation of uncertainty in runoff prediction and the value of data: An application of the GLUE approach. (submitted to *Water Resour. Res.*, October 1994).
- FREND, (1989) : "Flow Regimes from Experimental and Network Data, Vol.I, Hydrological Studies". Ed.Institute of Hydrology, Wallingford. 334 pp.
- Gabriele, S. and Arnell, N. (1991). A hierarchical approach to regional flood frequency analysis. *Water Resour. Res.*, 27(6), pp. 1281-1289.
- Gabriele, S. and Iiritano, G. (1996). Maximum likelihood estimator for the hierarchical regional TCEV model, UNESCO-AMHY FRIEND Annual Conference, Thessaloniki, Greece, September 25-27.
- Galea, G. (1989). Calcul des abaques QdF sur le bassin versant de la Sevre Nantaise. *Rap.Tech. CEMAGREF*, Lyon, France.
- Galea, G., Prudhomme, C. (1994). The Mono Frequency Synthetic Hydrograph (MFSH) concept: definition, interest and construction from regional QdF models built with threshold discharges for little mountainous basins with rapid runoff. *Int. Conf. Stara-Lesna, Slovakia*.
- Galea, G., Schuitema, N., Oberlin, G. (1990). Modele descriptif synthétique tri-dimensionnel des connaissances régionales en crues. *Int. Conf. "Regionalisation in Hydrology"*, 23-26 april, Ljubljana.
- Gilard O., Mesnil J. J. (1994) : La crue de Vaison-La-Romaine du 22 septembre 1992. *Informations Techniques du CEMAGREF*, no. 95, Note 2.
- Gilard, O., Oancea, V. (1992). Etude d'inondabilité du Rival. *Etude hydrologique*, CEMAGREF, Lyon, France.
- Greenwood J.A., Landwehr J.M., Matalas N.C. and Wallis J.R. (1979). Probability weighted moments: definition and relation to parameters of several distributions expressible in inverse form. *Water Resour. Res.*, 15(5), pp. 1049-1054.
- Guillot P., Duband D. (1967) : La méthode du GRADEX pour le calcul de la probabilité des crues à partir des pluies. *Colloque International sur les crues et leur évaluation*, Leningrad, 15-22 Août, IASH, publication n°84, 560-569. *Symposium International d'Hydrologie*, Fort Collins, sept.
- Guillot, P. (1993) : The arguments of the gradex method: a logical support to assess extreme floods. In: Kundzewicz, Z.W, Rosbjerg, D., Simonovic, S.P. & Takeuchi, K. (eds.): *Extreme Hydrological Events: Precipitation, Floods and Droughts (Proceedings of the Yokohama Symposium, 1993)*. IAHS Publ. no. 213, p.287-298.
- Guillot, P. and Duband, D., (1967) : La méthode du GRADEX pour le calcul de la probabilité des crues à partir des pluies-*Colloque International sur les crues et leur évaluation*, Leningrad, 15-22 Aout, AISH Publ., N. 84, 560-569. *Symposium International d'Hydrologie*, Fort Collins, Sep. 1967.
- Guillot, P. et Duband, D. (1967) : La méthode du GRADEX pour le calcul de la probabilité des crues a partir des pluies. *Journées de la SHF, question 1, rapport 7*, Paris, septembre 1967.
- Guillot, P., Duband, D. (1967). La methode du GRADEX pour le calcul de la probabillite de crues a partir de pluies. *Jour. SHF.*, Rap.7, Paris.

- Gupta, V. K., Mesa, O.J. and Dawdy, D.R. (1994) Multiscaling theory of flood peaks: Regional quantile analysis, *Water Resour. Res.*, Vol.30, n°12, pp. 3405-3421.
- Hebson, C.S. and Cunnane, C. (1987). Assessment of use of at-site and regional flood data for flood frequency estimation, in V. P. Singh (ed.), *Hydrologic Frequency Modelling*, pp. 433-448, D. Reidel, Dordrecht (NE).
- HEC, (1982) : "Computing Water Surface Profiles" User's Manual Hydrologic Engineering Center, U.S. Army Corps of Engineers, Davis, California.
- Hémain J. C., Dourens C. (1989) : A propos des inondations catastrophiques de Nîmes. *La Houille Blanche*, no. 6.
- Hershfield D. M. (1961) : Estimating the Probable Maximum Precipitation. *ASCE, J. of the Hydraul. Div.*, HYS, Sept.
- Hornberger, G.M., Beven, K.J., Cosby, B.J. and Sappington, D.E. (1985) : Shenandoah Watershed Study: Calibration of a topography-based, variable contributing area hydrological model to a small forested catchment. *Water Resour. Res.* 21, 1841-1850.
- Hosking J.R.M. (1990). L-moments: analysis and estimation of distributions using linear combination of order statistics. *J.R. Stat. Ser. B*, 52(1), pp. 105-124.
- Hosking J.R.M., Wallis J.R. and Wood E.F., (1985) : "An Appraisal of the Regional Flood Frequency Procedure in the UK Flood Studies Report". *Hydrol. sci. J.*, 30, 85-109.
- Hosking, J.R.M. (1991) : Fortran routines for use with the method of L-moments, Version 2. IBM Res. Rep. RC17097..
- Hosking, J.R.M., Wallis, J.R. and Wood, E.F. (1985) : An appraisal of the regional flood frequency procedure in the UK Flood Studies Report, *Hydrological Sciences J.*, 30(1): 85-109.
- Hosking, J.R.M., Wallis, J.R. y Wood, E.T., (1985) : "Estimation of the generalized extreme value distribution by the method of probability weighted moments". *Technometrics*.
- Jenkinson A. F. (1955). The frequency distribution of the annual maximum (or minimum) values of meteorological elements. *Quarterly Journal of the Royal Meteorological Society*, 87, 158.
- Kaspárek, L. et al. (1995) : Metody vypočtu hydrologických dat pro vodní hospodářství a ochranu ZP v podmínkách antropogenního ovlivnění a klimatických změn. Report of project 043.
- Kašpárek, L., Kolářova, S. and Moucha, V. (1989) : Povoden na Jílovském a Olšovském potoce v cervenci 1987 (Flood on the Jílovský and Olšovský Brooks in July 1987). *Vodní hospodářství* 39 (5A): 121-126.
- Kayhanfarid M., Oberlin G. (1995) : A new progressive option for the AGREGEE model, with better physical readability, and operational growing factor. Annual report FRIEND-AMHY n°5, UNESCO, Annual meeting FRIEND-AMHY topic IV (floods), Thessaloniki 25-27 sept. 1995.
- Kite, G.W. (1977). Frequency and risk analysis in hydrology. *Wat. Res. Publ.*, Fort Collins, Colorado.
- Lang M. (1995a) : Les chroniques en hydrologie. Thèse de doctorat, Université Joseph Fourier Grenoble, Cemagref Lyon, mai, 296p.
- Lang M. (1995b) : Renewal method : comparison between two sampling techniques by selection of annual maxima or threshold values. Annual report FRIEND-AMHY n°5, UNESCO, Annual meeting FRIEND-AMHY topic IV (floods), Thessaloniki 25-27 sept. 1995.
- Lang, M., Oberlin, G. (1993). Preliminary test for mapping the 100 year flood with the AGREGEE model. *Int. Conf. FRIEND*, 11-13 oct., Braunschweig, Germany.
- Loye-Pilot M. D., Pasquier C. (1994) : Les pluies exceptionnelles de la Toussaint 1933 en Corse. Publication présentée à "l'Assemblée générale à Aix en Provence du Comité National Français des Sciences Hydrologiques", DIREN.
- Marchi E., Giorgio R., Siccardi F. (1995) : The November 1994 flood event on the Po River. Structural and non-structural protection against the inundation. Report of the Hydraulic Institute of the University of Genova and Hydraulic Institute of the University Perugia.
- Margou, M. (1992) : "Agregée mode d'emploi". Séminaire International Annuel du Groupe AMHY de FRIEND, Perugia 92.
- Margoum M. (1992) : Estimation des crues rares et extrêmes : le modèle AGREGEE. Conceptions et premières validations. Thèse de doctorat, Ecole des Mines de Paris, Cemagref Lyon, GIS Hydrologie FRIEND-AMHY, 252p.
- Margoum M., Oberlin G., Lang M., Weingartner, R. (1994) : Estimation des crues rares et extrêmes : principes du modèle AGREGEE. *Hydrologie Continentale*, vol.9 (1), 83-98.
- Margoum, M. (1992) : Estimation des crues rares et extrêmes: Le modèle AGREGEE. Conception et premières validations. These, Ecole des Mines de Paris, CEMAGREF.
- Margoum, M. (1992). Estimation des crues rares et extrêmes: le modèle AGREGEE. Conception et premières validations. PhD Ecole des Mines, Paris.
- Michel C. (1982) : Extrapolation par la méthode du GRADEX. Note du 03-05, Cemagref Antony.

- Michel, C. et Oberlin, G. (1987) : Seuil d'application de la méthode du GRADEX. La houille blanche, no3.
- Michel, C., Oberlin, G. (1987a). Etude des crues rares, variante d'application de la méthode du GRADEX. Rap. CEMAGREF, Antony, IT no. 87, France.
- Miquel J. (1984) : Guide pratique d'estimation des probabilités de crue. Ed. Eyrolles, 160p.
- MOPU, (1990) : "Instrucción 5.2. - I.C.", Drenaje Superficial. Dirección General de Carreteras.
- Natural Environmental Research Council (1975). Flood Studies Report, 5 Volumi, Londra.
- NERC, (1975) : "Flood Studies Report". Nat. Environm. Res. Council. London, Vols, 1-5, 1100 pp.
- Oancea, V. (1994). Modeles d'estimation des crues rares et extrêmes. INONDABILITE: la construction automatique des Hydrogrammes Synthétiques Mono-Frequences (HSMF). Rap. Techn., CEE Grant,-Bruxelles, no.ERB-CIPA-CT-92-2112/1187.
- Oancea, V., Galea, G., Oberlin, G. (1992). L'utilisation des modèles QdF dans les synthèses régionales de l'écoulement maximal. Journ. Hyd. de l'ORSTOM, sept. 15-17, Montpellier, France.
- Oancea, V., Margoum, M. (1992). Estimation des crues rares et extrêmes par le modèle AGREGEE: etude de cas. Journ. Hyd. de l'ORSTOM, sept. 15-17, Montpellier, France.
- Oberlin G., Margoum M. (1993) : AGREGEE, a French design flood approach. In FRIEND report, Vol. I Hydrological Studies, UNESCO, IHP IV, Ed. A. Gustard, 146-154.
- Oberlin, G., Margoum, M. (1991). First formalisation of AGREGEE in the field of non exponential rainfall distributions. EGS-XVI Gen. Assemb., 22-26 april, Wiesbaden, Germany.
- Oberlin, G., Margoum, M. (1991). Objectifs du modèle AGREGEE. IT no. 84, CEMAGREF, Paris.
- Oberlin, G., Oancea, V. (1993b). Les solutions apportées par l'hydrologie. La Recherche, vol.24, no.257, Paris.
- Pardé M. (1961) : Sur la puissance des crues en diverses parties du monde. Geographica, Numero Monografico, Departament de Geografia Aplicada del Instituto Elcano, Año VIII, Zaragoza, Enero-Diciembre.
- Parment B., Burgdorffer M. (1996) : Extreme discharges in the Netherlands : 1993, 1995 and 2100. Operational forecasting and long term expectations. Paper accepted by the EGS Journal Physics and Chemistry of the Earth.
- Potter, K. W. (1987). Research on flood frequency analysis: 1983-1986, Reviews of Geophysics, Vol.25, 2, pp. 113-118.
- Prudhomme, C. (1993). Analyse et regionalisation des régimes hydrologiques méditerranéens. Ph.D., CEMAGREF, Lyon-LHM, Univ. des Scien. Tech., Montpellier, France.
- Reed, D. (1992). Rainfall frequency analysis for flood design. NATO ASI on Coping with floods, Centro E. Majorana, Erice (TP), Italy.
- Rodier I. A., Roche M. (1984) : World Catalogue of the Maximum Observed Floods. IAHS Publication, no. 143.
- Romanowicz, R., Beven, K. and Tawn, J.A. (1994) : Evaluation of predictive uncertainty in nonlinear hydrological models using a Bayesian approach. In: V. Barnett and K.F. Turkman (Editors), Statistics for the Environment 2: Water Related Issues. Wiley, Chichester, UK, pp. 297-317.
- Rosbjerg D. (1985) : Estimation in partial duration series with independent and dependent peak values. J. of Hydrology, 76, 183-195.
- Rosbjerg, D., Madsen, H., and Rasmussen, P.F. (1992). Prediction in partial duration series with generalized Pareto-distributed exceedances. Wat.Resour.Res. 28(11), 3001-3010.
- Rossi, F. and P. Villani (1988). La regionalizzazione della piena annuale media tramite un approccio geomorfoclimatico. Atti del XXI Convegno di Idr. e Costr. Idr., pp.225-243, L'Aquila.
- Rossi, F. and Versace, P. (1982) Criteri e metodi per l'analisi statistica delle piene. Valutazione delle piene, CNR-P.F. Conservazione del suolo, n° 165, pp. 63-130.
- Rossi, F. and Villani, P. (1992a). Regional methods for flood estimation, NATO ASI on Coping with floods, Centro E. Majorana, Erice (TP), Italy.
- Rossi, F. and Villani, P. (1992b). Valutazione delle piene in Campania. CNR-GNDICI, Salerno.
- Rossi, F., Fiorentino, M. and Versace, P. (1984). Two component extreme value distribution for flood frequency analysis, Water Resour. Res., 20(7), 847-856.
- Rossi, F., Fiorentino, M. and Versace, P. (1984). Two-component extreme value distribution for flood frequency analysis. Wat. Resour. Res.20(7), 847-856.
- Rouselle, J. (1972) : On some problems of flood analysis, Ph.D. dissertation, Colorado State University, Fort Collins.
- Saelthun N. R., Oberlin G. (1993) : Techniques for extreme rainfall and runoff estimation. In FRIEND report, Vol. I Hydrological Studies, UNESCO, IHP IV, Ed. A. Gustard, 139-179.

- Saelthun, N.R. and Oberlin, G. (1993) : Extreme Rainfall and Runoff Estimation. Synopsis of alternative methods. In: Gustard, A. (ed.) Flow Regimes from International Experimental and Network Data. FRIEND, IHP IV, UNESCO. IH Wallingford, p.139-146.
- Savenije H. (1996) : Recent Extreme floods in Europe and USA; Challenges for the Future. Paper accepted by the EGS Journal Physics and Chemistry of the Earth.
- Schiller H. (1987) : Ermittlung von Hochwasserwahrscheinlichkeiten am schiffbaren Main und überregionaler Vergleich der Ergebnisse. Beiträge zur Hydrologie, München.
- Sherman, L.K., (1932) : "Stream-flow from rainfall by the Unit-Graph Method". Eng. News Rec. 108, 501-505.
- Soil Conservation Service (SCS), (1972) : "National Engineering Handbook, Section 4". US Department of Agriculture , Washington, D.C.
- Spear, R.C. and Hornberger, G.M. Eutrophication in Peel Inlet. II. Identification of critical uncertainties via Generalised Sensitivity Analysis (1980). Water Res., 14, 43-49.
- Spreafico M., Aschwanden H. (1991) : Débits de la crue dans les cours d'eau suisses. Vol. III et IV, Publ. Service hydrologique et géologique national, Communication no. 16 and no. 17, Berne.
- Spreafico M., Stadler K. (1988) : Débits de crue dans les cours d'eau suisses. Vol. II, Publ. Service hydrologique et géologique national, Communication no. 8, Berne.
- Stanescu V. Al. (1967) : Danube between Bazias and Ceatal Izmail (in Romanian). Hydrological Monograph, ISCH Press, Bucharest.
- Stanescu V. Al., Alexandrescu G., Mociornita C. (1972) : Considérations sur la fréquence des crues en 1970 sur les rivières de notre pays (en roumain). Rev. Hidrotehnica, no. 12, Bucarest.
- Stanescu V. Al., Kikkawa H. (1976) : World Catalogue of Very Large Floods. Studies and Reports in Hydrology, The UNESCO Press.
- Stanescu V. Al., Mustatea A., Oberlin G. (1995) : Les crues de Roumanie : Formation et particularités spécifiques. Communication présentée au "Troisième Rencontres Hydrologiques Franco-Roumaine", Montpellier.
- Stanescu V. Al., Serban P., Manoliu M. (1976) : Hydrological characteristics of Arges River floods of July 1975 (in Romanian). Study and Research in Hydrology., vol. XLV, IMH, 63-104.
- Tavares L.V., Da Silva, J.E. (1983) : Partial duration series method revisited. J. of Hydrology, 64, 1-14.
- Témez J.R., (1991) : "Extended and Improved Rational Method. Version of the Highways Administration of Spain". Proc. XXIV Congress. Madrid (Spain), 1991. Vol A., pp.33-40.
- Todorovic, P. (1970) : On some problems involving random number of random variables, Ann. Math. Statistics, 14 (3), pp. 1059-1063.
- U.S. ARMY (1960) : "Routing of Flood Through River Channels". Engineer Manual 1110-2-1408". U.S. Army Corps of Engineerins, Washington, D.C.
- UNESCO, (1977) : "Research on Urban Hydrology". Vol. 1 and 2, edited by M.B. McPherson, UNESCO, Paris, France.
- USBR, (1989) : "Flood Hydrology Manual". Bureau of Reclamation, U.S. Department of the Interior.
- USSCS (1985) : National Engineering Handbook. United States Soil Conservation Service, Department of Agriculture, section 4, Hydrology, Chap. 10, March.
- Versace, P., Ferrari, E., Gabriele, S. and Rossi, F. (1989). Valutazione delle piene in Calabria, CNR-GNDICI, Cosenza.
- Versace P., a cura di, (1994) *La valutazione delle piene in Italia. Rapporto nazionale di sintesi*, (draft), CNR-GNDICI, Roma, Italy (in Italian).
- Wang Q.J (1991) : The POT model described by the generalized Pareto distribution with Poisson arrival rate. J. of Hydrology, 129, 263-280.

Chapter 5

Heavy Rains

Short introduction

M.C. Llasat

Floods have achieved the distinction in some countries of being the natural hazard that year-in year-out produces the most casualties. Last August in Spain, a flash flood which affected a camp site in the Pyrenees led to 85 deaths, although the most catastrophic one recorded in this country was the flash flood which occurred in September 1962 in Catalonia, with more than 815 deaths in less than 3 hours. In the South of France, the floods recorded on September 22, 1992, produced 41 casualties in the Ouveze basin. The same event produced catastrophic floods in NW Italy, a region which was again affected in September 1993 and November 1994 by this kind of event. More than 2 200 people died in 1988 as a consequence of flooding of the Ganges and the Brahmapoutre in Bangladesh. In July 1993 the Mississippi basin was affected by one of the biggest floods in US history : 9 states were affected, 47 people lost their lives and damage amounted to over 12 billion dollars. During the same month, 3 000 people died in India and Nepal as a consequence of floods.

Floods and inundations are a hydrometeorological hazard. Both hydrology and meteorology play a major role. Heavy rains are necessary but insufficient to cause them. Other conditions such as previous precipitation, terrain and surface runoff characteristics are also important. Due to the fact that other conditions are sufficiently well-treated in other chapters of this Report, this chapter focuses on those aspects relating to rainfall, and, essentially, heavy rains.

An analysis of heavy rains can be undertaken from different viewpoints, and that is in fact how it has been approached in the FRIEND project. This chapter is fair proof of that approach, for not only is the meteorological problem of heavy rains tackled, but account is also taken of modelling it from a statistical point of view, assessing it by teledetection, as in the case of meteorological radar, orographic influence, analysis of the major events and regionalization thereof. Finally, the orographic aspect is essential if we bear in mind the complex orography of the Mediterranean countries, frequent victims of heavy rains, and the influence which this factor can have on the development of convection.

ooooo

Brève introduction

M.C. Llasat

Dans plusieurs pays, les crues se sont révélées être les catastrophes naturelles causant, année après année, le plus grand nombre de victimes. Au cours du mois d'août 1996, en Espagne, une crue soudaine a entièrement détruit un camping installé dans les Pyrénées et a causé la mort de 85 personnes. Mais l'événement le plus catastrophique de ce pays a été enregistré en Catalogne, au cours du mois de septembre 1962, causant plus de 815 morts en moins de 3 heures. Dans le sud de la France, les crues qui se sont produites le 22 septembre 1992 ont entraîné 41 morts dans le bassin de l'Ouvèze. Ce même événement a produit des crues catastrophiques dans le nord ouest de l'Italie, une région qui fût à nouveau affectée par les pluies fortes et les crues en septembre 1993 et novembre

1994. Plus de 2 200 personnes ont trouvé la mort en 1988 lors des crues du Gange et du Brahmapoutre au Bangladesh. En juillet 1993, le bassin du Mississippi a été touché par une des plus fortes crues de l'histoire des Etats Unis : 9 Etats furent touchés, 47 personnes perdirent la vie, et le montant des dommages s'éleva à plus de 12 milliards de dollars. Au cours du même mois, 3 000 personnes moururent en Inde et au Népal à la suite d'inondations.

Les crues et les inondations sont des aléas hydrométéorologiques où l'hydrologie et la météorologie jouent un rôle également majeur. Les pluies fortes sont « nécessaires » à la constitution de tels événements, mais non suffisantes. D'autres conditions, telles que les précipitations antérieures, les caractéristiques du terrain et celles des écoulements, sont aussi importantes. Etant donné que certaines de ces autres conditions sont déjà analysées dans d'autres chapitres de ce rapport, le présent se focalisera sur les aspects relatifs aux seules précipitations et essentiellement aux plus fortes d'entre elles.

L'analyse des pluies fortes peut être réalisée à partir de points de vue très différents, mais néanmoins complémentaires, et c'est ce qui a été fait dans le cadre du projet FRIEND. Ce chapitre est une bonne démonstration de cette approche, dans la mesure où l'on a considéré non seulement le problème météorologique des pluies fortes, mais aussi la modélisation d'un point de vue statistique, la télédétection (cas des radars météorologiques), l'influence orographique, l'analyse des événements les plus importants, et la régionalisation.

Finalement, si on garde à l'esprit l'orographie très complexe de nombre de régions, dont les pays méditerranéens, fréquemment victimes de pluies fortes, ainsi que l'influence de ce facteur dans le développement des convections atmosphériques, l'aspect orographique est tout à fait essentiel dans le domaine des pluies.

Rain intensities in the french Alps

Intensités pluvieuses dans les Alpes françaises

I. Desurosne, E. Leblois

Introduction

L'évaluation des risques de crues s'appuie sur la connaissance des précipitations. Or les montagnes sont peu instrumentées, et la régionalisation y est difficile. Ces dernières années, de nombreux efforts ont été faits sur la question¹. On décrit ici deux programmes s'étant intéressés aux Alpes Françaises dans le cadre du groupe FRIEND-AMHY (thème VI, « Pluies »), l'un à l'échelle régionale, l'autre à l'échelle du versant. Ensemble, ils semblent permettre l'élaboration d'un modèle de transfert des connaissances des précipitations de plaine ou de vallée, plus fiables, vers les zones d'altitude, ceci pouvant contribuer à une **cartographie fine des aléas à l'échelle régionale**, au moins sur les Alpes.

1 Un programme de connaissance régionale des précipitations : IdF-Sud/Est

Ce programme, clos en 1996, a été mené à terme par le Cemagref (*de Lyon et de Grenoble*), EdF et l'IMG-LTHE de Grenoble, avec l'aide de la Région Rhône-Alpes (Xe contrat de plan Etat-Région).

1.1 Les données

Pour 66 pluviographes, situés entre Jura et Méditerranée, on dispose de chroniques de pluie maximale hebdomadaire à 6 pas de temps choisis pour l'étude (de *1H* à *24H*). Ces pluviographes se modélisent bien un par un par un modèle de *renouvellement* (*loi de Poisson + loi exponentielle*). On en déduit les principaux quantiles pour les 66 postes.

1.2 Cartographie exploratoire des quantiles de pluie

Les quantiles sont interpolés à l'aide d'un outil géostatistique banal. La période de retour apparaît sans effet sur l'allure du champ de l'aléa pluviométrique, mais la durée de la pluie est essentielle : pour une heure (figure 1, page suivante), les valeurs sont fortes en vallée du Rhône et sur la côte méditerranéenne, faibles dans une large cuvette des Alpes centrales centrée sur le nord des Hautes-Alpes et la Savoie. Le champ est beaucoup plus nuancé au pas de temps journalier. On reconnaît, du Nord au Sud, le Jura, le Chablais et le massif du Mont-Blanc, la Chartreuse, très nette, suivie par le Vercors, Belledonne, les Ecrins et le Dévoluy, enfin la région du Mont Pelat, le Ventoux et la Montagne de Lure ; le champ présente des plages faibles dans la vallée de la Durance, de la Maurienne et vers Genève (figure 2).

Nous en déduisons que l'influence des facteurs locaux est plus importante pour l'estimation des quantiles de pluie longue que pour celle des quantiles de pluie courtes.

¹ Cévennes-Vivarais, Vosges, Pyrénées Orientales françaises et espagnoles font l'objet de recherches intensives depuis plusieurs années ; voir [Bois et al, 1995], [Humbert et Perrin, 1993]...

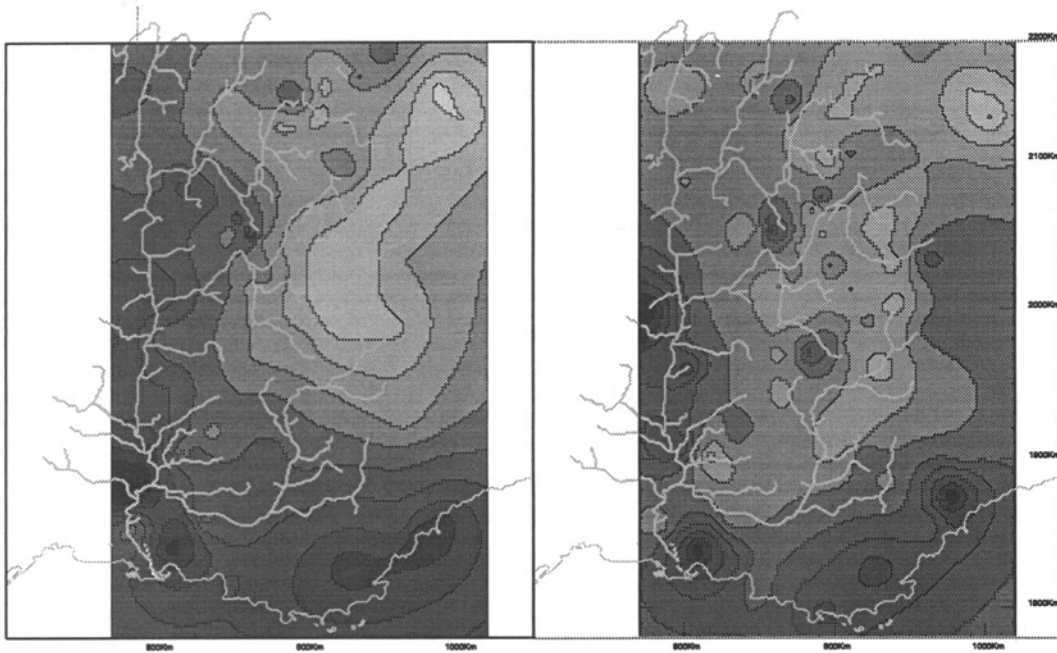

Figure 1 : quantiles de pluie d'une heure décennale. Les valeurs vont de 0 à 60 mm.

Figure 1 : one hour rainfall quantiles, ten year return period. Grey levels are from 0 to 60 mm.

Figure 2 : quantiles de pluie de 24 heures décennale. Les valeurs vont de 0 à 200 mm.

Figure 2 : 24 hour rainfall quantiles, ten year return period. Grey levels are from 0 to 200 mm.

1.2 Liaison entre les pas de temps

Les usuels coefficients de Montana ne pourront pas servir à la régionalisation, car ils cumulent deux échelles différentes d'influence du relief sur les quantiles (*régionale pour les pluies de durée brève, régionale ET locale pour les quantiles de pluie de durée longue*). Pour chaque période de retour, on propose de relier les quantiles des durées intermédiaires aux quantiles de 1H et de 24H « réputés connus » comme suit :

On considère la distribution du coefficient $k(d,T)$ tel que :

$$P(d,T) = P(1H,T) \left(\frac{P(24H,T)}{P(1H,T)} \right)^{k(d,T)} \quad \text{et donc} \quad k(d,T) = \frac{\text{Ln}\left(\frac{P(d,T)}{P(1H,T)}\right)}{\text{Ln}\left(\frac{P(24H,T)}{P(1H,T)}\right)}$$

$k(d,T)$ est égal à 0 si $d=1H$, égal à 1 si $d=24H$; pour chaque autre choix de d et T , l'échantillon des 66 valeurs apparaît chaque fois suivre une loi normale, dont voici les paramètres (pour $T=10$ ans) :

durée	1 heure	2 heures	3 heures	6 heures	12 heures	24 heures
m	0	0.177	0.313	0.542	0.778	1
σ	0	0.051	0.070	0.063	0.072	0

Les valeurs centrales (m) dépendent en fait très peu de la période de retour. $k(d,T)$ pourrait donc être utilisé pour l'estimation des quantiles de durée intermédiaire, si l'on disposait d'un pluviomètre local donnant connaissance de la pluie journalière, et que l'on admettait une interpolation limitée aux pluies d'une heure. Notons qu'il reste le besoin d'une information pluviométrique locale, puisqu'à 24

heures l'influence locale du relief ne peut être ignorée, ce qui ne règle pas la question de la haute montagne.

1.3 Note sur la saison à risque, fonction du pas de temps

La lame d'eau précipitée est un descripteur important d'une pluie intense de durée donnée. Sa période de retour aussi, relativement à la climatologie locale. On pourrait procéder à une homogénéisation : la pluie locale X de durée donnée étant réputée suivre une loi exponentielle de paramètres X_0 et Gd locaux, chaque valeur de précipitation P observée, réalisation de X , est remplacée par pluie dite réduite P' de même période de retour apparente selon une loi exponentielle de paramètres conventionnels $X_0' = 0$ et $Gr' = 1$:

$$\frac{P' - 0}{1} = Ln(T) = \frac{P - X_0}{Gr}$$

Si pour chaque durée d'étude, on représente toutes les valeurs de P' face au jour de l'année, apparaissent les saisons à risque suivantes :

Pour les pluies de 1 à 3 heures : *de juin à octobre, mais surtout juin à août*; saison **très** marquée ;
 Pour les pluies de 6 heures, *de juin à octobre, mais surtout à partir d'août*; saison **assez** marquée ;
 Pour les pluies de 12 et 24 heures, *septembre à novembre*, saison **peu** marquée, de forts abats pluvieux pouvant se produire tout au long de l'année.

Il n'a pas été vérifié que les 66 postes formaient un tout homogène, et une autre région pourrait présenter des caractéristiques différentes. Il faut au moins vérifier la réalité de la saison à risque sur la base des pluies journalières avant de renoncer au dépouillement complet des pluviogrammes.

1.4 Epicentrage

Le phénomène d'épicentrage correspond à la différence entre le quantile de la pluie observable sur un poste fixe, et celui de la pluie maximale en un point quelconque d'une surface donnée. Il dépend de l'indépendance spatiale relative entre les pluies [Galéa et al., 1983]. La prise en compte de ce phénomène permettrait de traiter du dimensionnement hydrologique adapté aux ouvrages linéaires (*une ligne de chemin de fer, défailante dès qu'un seul de ses ouvrages d'art l'est*), et de rendre compte de l'apparente incohérence entre les périodes de retour que l'on peut associer à un même événement selon qu'on l'examine localement ou régionalement.

Sur la zone d'étude, on peut ainsi estimer que la pluie « délocalisée » (*quelque part sur l'ensemble de la rive Est du Rhône*) vaut environ 3,5 fois la pluie « locale » de même période de retour pour les pluies d'une durée d'une heure. L'effet est un peu moins fort sur les pluies d'une durée de 24 heures (*de l'ordre de 2,8 fois*)

1.5 Perspectives

Avec la collaboration de EDF/DTG, le LTHE exploite en 1997 quelques autres pluviographes alpins, ce qui pourrait lui permettre de vérifier (ou non) les résultats ici avancés [Kieffer, thèse en cours] ; des contacts noués récemment avec l'Italie donnent espoir de pouvoir nos observations avec des observations homologues et donc d'appréhender leur validité spatiale ; voir aussi ci-dessous.

2 Un programme de connaissance locale des précipitations d'altitude : le TPG

2.1 Le site expérimental

Un alignement de 23 pluviographes nommé TPG (Transect de Pluviographes pour l'analyse et la modélisation de Gradients pluviométriques d'altitude) est implanté depuis 1986 entre Lyon et le massif de Belledonne, traversant sur 100 km trois massifs montagneux d'altitude croissante d'Ouest en Est : Bas-Dauphiné ($\cong 1000$ m), Chartreuse ($\cong 2000$ m) et massif de Belledonne ($\cong 3000$ m) (Figure 3). Cet axe est celui de la propagation des perturbations supposées les plus actives. Les postes sont plus reserrés dans les versants.

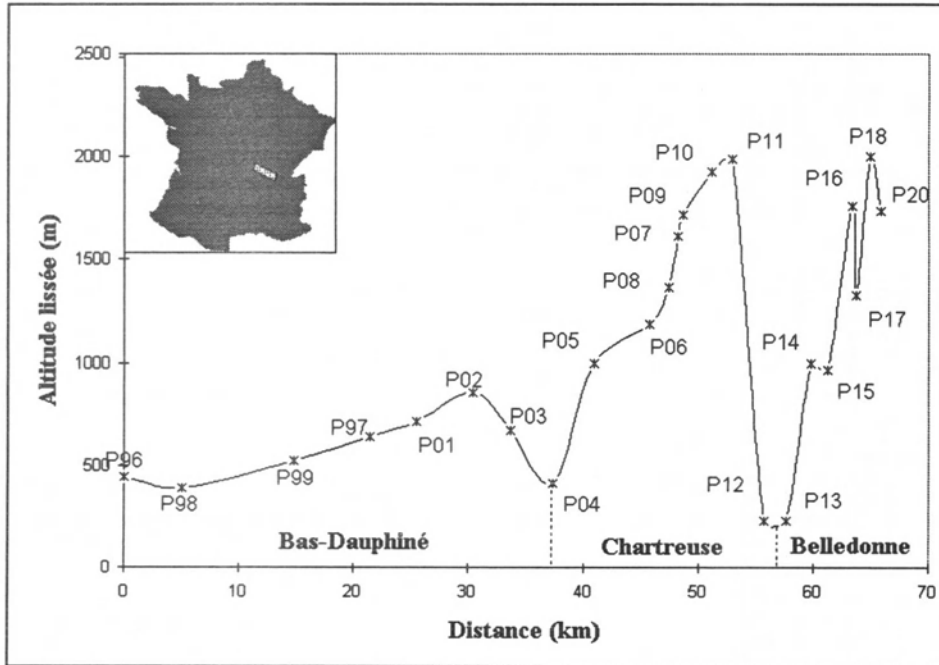

Figure 3 : Le TPG : localisation et profil en long ([Desurosne, 1993 ; Desurosne et al. , 1996]).

Figure 3 : The TPG : situation and elevation profile ([Desurosne, 1993 ; Desurosne et al. , 1996]).

La saison d'observation va de mi-mai à octobre, avec des lacunes dues aux conditions particulièrement rudes auxquelles sont confrontés les appareils.

Ce réseau soutenu par le Cemagref est utilement complété par les réseaux conventionnels avoisinants : celui de Météo-France, et celui d'Electricité de France (*Direction Technique Générale, Grenoble*). Il pourrait bénéficier du radar et des radiosondages de Lyon (*Météo-France*).

2.2 Climatologie : le « mauvais temps » pendant la période d'observation 1987-1995

D'après les travaux de Blanchet [1990, 1996], qui précise les zones des Alpes touchées par les flux perturbés, le TPG est dans une zone où les flux d'Ouest sont les plus fréquents. Cependant ces flux n'apparaissent pas être à l'origine des plus forts abats pluvieux observés sur le TPG, au moins sur des durées courtes, car ils sévissent essentiellement en période hivernale. Les trajectoires entièrement enregistrées (*isotherme 0°C au dessus de 2000 m*) sont estivales, et concernent surtout des perturbations à caractère orageux, conséquences de flux de Sud ou de Sud-Ouest, de marais barométriques, éventuellement de fronts stationnaires et de gouttes froides. Les chroniques de pluie résultantes sont analysées dans ce qui suit.

2.3 Modèles locaux Intensités-Durées-Fréquences (IdF)

Le modèle IdF (*Intensités-durées-Fréquences*) traduit le régime des pluies intenses en un point donné. Basé techniquement sur un modèle dit de renouvellement [Lang, 1995], il examine la distributions des pluies intenses de différentes durées, avec liaison entre durées par des lois de Montana, aboutissant à la construction d'un abaque propre à chaque poste d'observation (figure 4) . D'un réel intérêt opérationnel, cette approche sert de base aux études de crues, *via* des modèles tels que celui du GRADEX ou AGREGEE [Margoum, 1994].

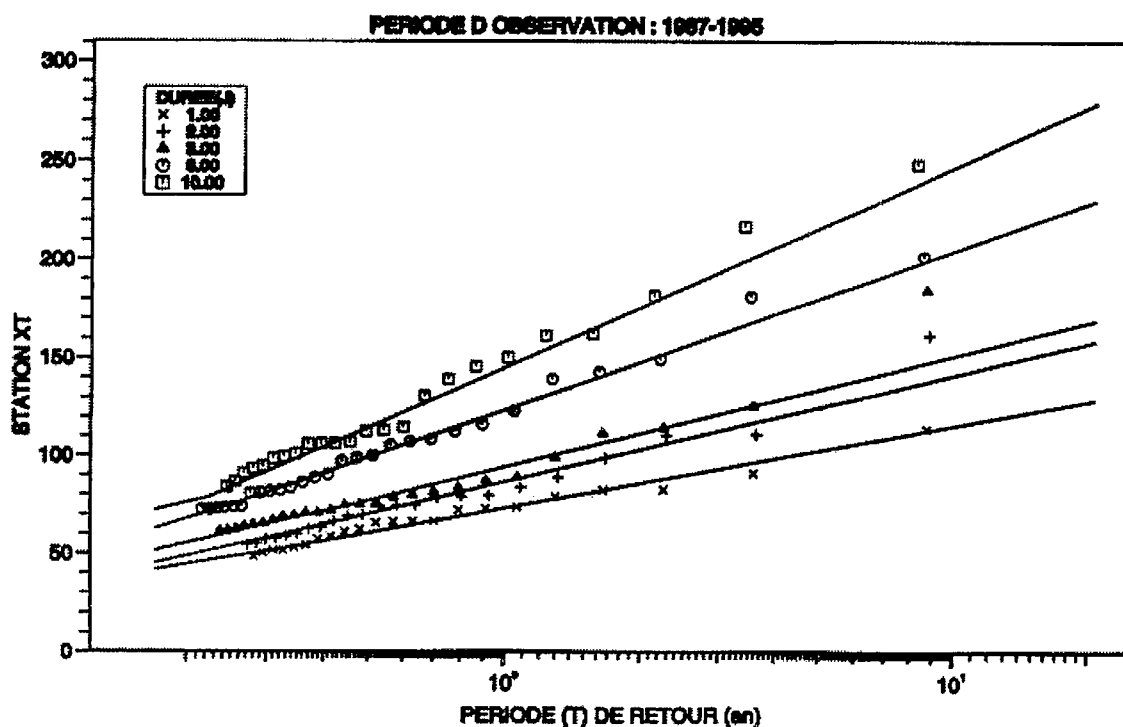

Figure 4 : Exemple d'un abaque Intensités-durées-Fréquences (figure tirée de [Watremez, 1996])

Figure 4 : An example of Frequency-duration-Intensity plot (figure from [Watremez, 1996])

On applique cette technique ici. Pour chaque durée et période de retour, on déduit de l'abaque une estimation locale du quantile local de pluie maximale. L'évolution de ce quantile le long du transect montre le rôle joué par le relief (figure 5) . Ce rôle ne dépend pas de la période de retour, mais beaucoup de la durée : aux **faibles durées** (≤ 12 heures), les reliefs n'ont guère d'influence. Watremez [1996] a montré qu'il serait possible de considérer une stagnation de ces quantiles à l'échelle du TPG, résultat qui sera exploité ci-après. Ceci correspond à ce que le programme IDF/SE a montré : le relief alpin agit comme un bouclier, et la décroissance des quantiles de précipitations de courte durée est progressive du bord du massif vers l'intérieur. Dans le cadre d'une analyse plus fine, il faudrait certainement nuancer.

Pour des **durées plus longues** (≥ 1 jour), les reliefs exacerbent les abats pluvieux ² :

² Dans la Chartreuse les précipitations semblent s'effondrer à partir d'un « point d'inversion » situé vers 1000 m. L'explication peut être géographique (présence d'une vallée d'altitude modérée à l'intérieur du massif) ou physique (relief chaoté occasionnant un déficit du « rendement pluviogène »). Mentionné dans d'autres travaux [Desurosne et al., 1996], remarqué par d'autres organismes (EdF), ce phénomène ne concernerait que les précipitations estivales, orageuses.

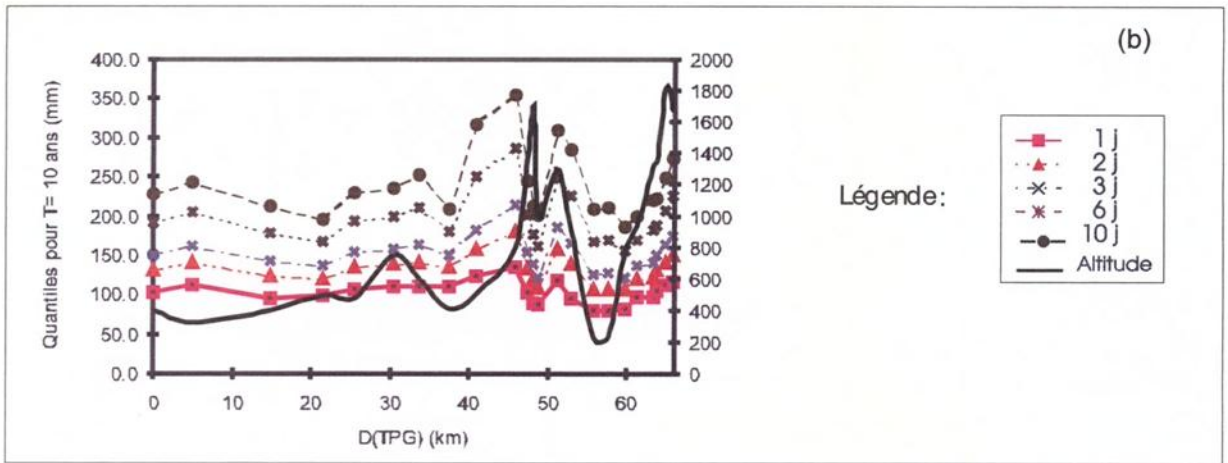

Figure 5 : Structuration par les reliefs (en trait plein en arrière plan), pour des durées supérieures à la journée, du champ des quantiles de période de retour 10 ans. Période d'observation : 1987-1995. D(TPG) représente l'abscisse le long du transect, compté de la station P96.

Figure 5 : Elevation influence on ten year rainfall quantiles, for durations above one day (elevation is plotted as a solid line). Data from 1987-1995.

D'Ouest en Est, le gradient hypsométrique des intensités diminue ; les quantiles sur la Chartreuse, d'altitude inférieure à 2000 m, sont bien supérieurs à ceux relevés sur Belledonne, dont l'altitude croît jusqu'à 3000 m. On note bien l'amorce d'assèchement des masses d'air lors de leur progression dans le massif alpin, bien connu dans des vallées internes (Maurienne).

2.4 Modélisation des précipitations d'altitude

On part du lissage proposé dans le programme IdF-Sud/Est :

$$P(d, T) = P(1H, T) \cdot \left[\frac{P(24H, T)}{P(1H, T)} \right]^{k(d, T)}$$

avec

P(d,T) le quantile de durée d (heures),
 P(1h,T) le quantile horaire,
 P(24h,T) le quantile journalier,
 le tout de période moyenne de retour T (ans) ;

k(d,T) étant la valeur moyenne de l'échantillon expérimental de ces paramètres, à T et d fixées.

Les coefficients k(d,T) sont représentables, sur le TPG, par la formulation

$$k(d, T) = -6,25 \cdot 10^{-3} + 7,60 \cdot 10^{-3} \cdot \ln T + (0,320 + 5,51 \cdot 10^{-3} \cdot \ln T) \cdot \ln d$$

valable pour d ∈ [1 h, 10 j] et T ∈ [2, 50 ans] (mais k varie en fait très peu avec la période de retour).

Reste à estimer les champs d'intensités horaires et journalières. Pour les précipitations horaires, une loi unique paraît suffisante à l'échelle du transect :

$$\bar{P}(d = 1h, T) = 23,2 + 6,04 \cdot \ln(T)$$

Pour les précipitations de 24 heures, les quantiles de pied de pente (en station dite de référence, et notée P_{Ref}) peuvent être transférées en altitude par un facteur du premier ordre en X, X représentant soit la dénivelée au poste de référence, soit la distance à ce poste (pour le Bas-Dauphiné). La formulation générale devient alors :

$$P(d, T) = P(1H, T) \cdot \left[\frac{(1 + a \cdot X) \cdot P_{Ref} (24H, T)}{P(1H, T)} \right]^{k(d, T)}$$

Le gradient (altimétriques ou kilométrique) prend les valeurs suivantes³ :

a =	0,45 % / km	dans le Bas-Dauphiné ;
a =	4 % / 100 m	en versant Ouest de la Chartreuse (sous le <i>point d'inversion cité</i>)
a =	-4 % / 100 m	à l'intérieur de la Chartreuse ;
a =	4,2 % / 100 m	en le versant Ouest de la Chartreuse ;
a =	2 % / 100 m	en le versant Ouest de Belledonne.

Ce gradient est quasiment constant de part et d'autre de la Chartreuse et se réduit de moitié en Belledonne. Il serait intéressant d'examiner cette décroissance plus en avant dans le massif alpin.

La figure 6 illustre la comparaison entre les quantiles modélisés et les quantiles originels (issus d'analyse des pluviomètres) pour la période de retour de 10 ans. Pour les autres périodes de retour, on consultera le récent rapport de synthèse du programme TPG [Desurosne et al., 1996]).

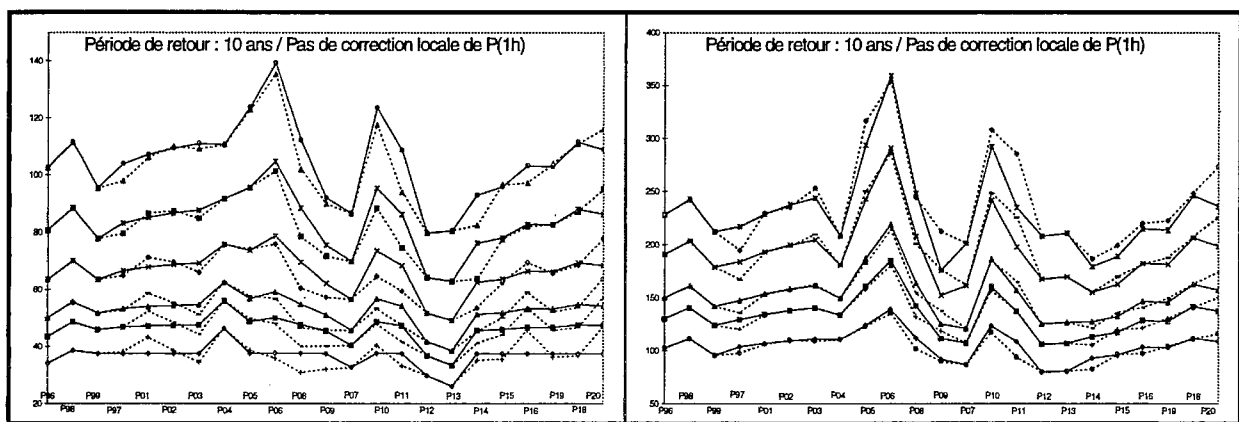

Figure 6 : Comparaison des résultats de la modélisation (traits pleins) avec les quantiles supposés vrais (issus de l'analyse statistique) pour la période de retour de 10 ans. Les abscisses portent l'ordre Ouest-Est, en ordonnées sont les quantiles (en mm). La partie gauche de cette figure concerne les durées inférieures ou égales à la journée (de bas en haut : 1, 2, 3, 6, 12 et 24 heures) et celle de droite les durées supérieures (de bas en haut : 1, 2, 3, 6 et 10 jours).

Figure 6 : Fit of the model (solid lines) to observed quantiles (points on dashed lines) for ten year return period. Rainfall in mm ; West is left, East is right. Left figure is for duration under one day, right figure is for duration above one day.

L'erreur commise, généralement entre 5 et 10 %, dépasse rarement les 20%, et paraît acceptable compte tenu des incertitudes d'estimation des quantiles (et des difficultés des mesures in situ). Le modèle semble valide à l'échelle du TPG.

2.5 Conclusion

Le modèle synthétique d'intensités de précipitations dans le massif préalpin du Nord, est adapté à la densité des informations disponibles, unique à l'échelle du TPG, moyennant un coefficient par massif, et est **opérationnel, au moins localement**, car il ne fait appel qu'à

³ il n'y a pratiquement pas de dispersion autour de ces valeurs moyennes, pour les plages de durées et de période de retour indiquées dans la formulation de $k(d,T)$

① des connaissances de plaine ou de vallée ([Leblois & Desurosne, 1994 ; Leblois, 1996], [Kieffer, thèse en cours]) ;

② des gradients kilométriques (*sur les bords du massif alpin*) et altimétriques (*ailleurs*), qu'il devrait être possible, *in fine*, de régionaliser.

3 Perspectives

Les deux études qui précèdent invitent à préciser la régionalisation de gradients pluviométriques sur l'ensemble des Alpes françaises, pour confirmer (*ou infirmer*) une décroissance de ces derniers avec la progression au coeur du massif alpin.

Un programme européen (*MAP : Mesoscale Alpine Programme*), initié en 1994 par le service météorologique suisse dans le but d'améliorer la connaissance et la prévision des épisodes de fortes précipitations sur l'arc alpin, et auquel sont associés à présent les hydrologues, devrait donner des éléments à ce propos. Dans le cadre de ce projet, des tests complémentaires sur les précipitations de l'Arc alpin pourraient être faites sur un réseau localisé sur le versant Sud de ce massif en Autriche, dont la morphologie s'apparente à celle du TPG : influence de la mer (Méditerranée ici) diminuant au fur et à mesure de la progression dans le massif, altitude des massifs croissant,

Trajectoires des noyaux pluvieux dans des chaînes montagneuses côtières

Rain cluster paths in coastal chains

M. Brilly

1 Introduction

The Soca (Isonzo) river watershed is the region with the highest precipitation in Slovenia and in the Friuli-Venezia Giulia region. It is also part of a belt (on the southern flank of the Alps, from the Mediterranean to the Panonian climate), with probably the maximum number of days with storms in Europe. The precipitation rate, more than 2500 millimeters per year, is also high in the European context. In the upper part of the Soca river watershed, thunderstorms and floods are quite frequent. Long term (1951-1986) statistical analysis of thunderstorms shows that there are more than 40 such storms per year.

The Soca watershed incorporates high alpine mountain and lower alpine regions, karstic plateau, low hillock is covered in vineyards, wide lowlands and part of the Mediterranean maritime region. The watershed has an area of 3450 km² and, in this research, an upper mountainous area of 2245 km² is also included. This mountainous area (Figure 1) has peaks over 2500 m high and canyons deeper than 1000 meters. The Soca River rises from the center of Julian Alps and its upper course is typically alpine, incorporating valleys with steep slopes. The central part of the Soca crosses two valleys, the Idrijca valley and the Baca valley, and is trapped between regions of flysch and limestone. The lowland course of the Soca crosses the hilly region of the Vipava Valley, flows downstream through a wide flat area of the maritime province and to the Adriatic sea (Brilly et al, 1995, Figures 1 and 2).

We divided the Soca river watershed into 25 sub-watersheds for hydrological modelling, (Figure 1 and Table 1). These sub-watersheds are from 3 to 182 Km² in surface area. The mean sub-watershed altitudes are between 50 and 1319 m. and the differences between the minimum and maximum altitudes are more than 2500 m. in the upper part of the watershed (Table 1). Rainfall data were collected daily at fifty rainfall stations (Figure 2) and eight gauging stations in Italy and rives Slovenia. Only seven of the rainfall stations were equipped with a recording.

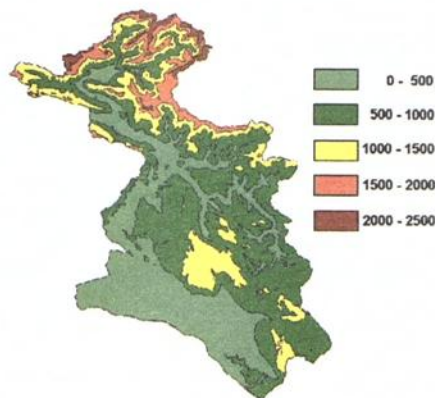

Figure 1 : The Soca watershed relief map with 500 m. contours

Figure 1 : La carte du relief du bassin du fleuve Soca, avec équidistance de 500 mètres

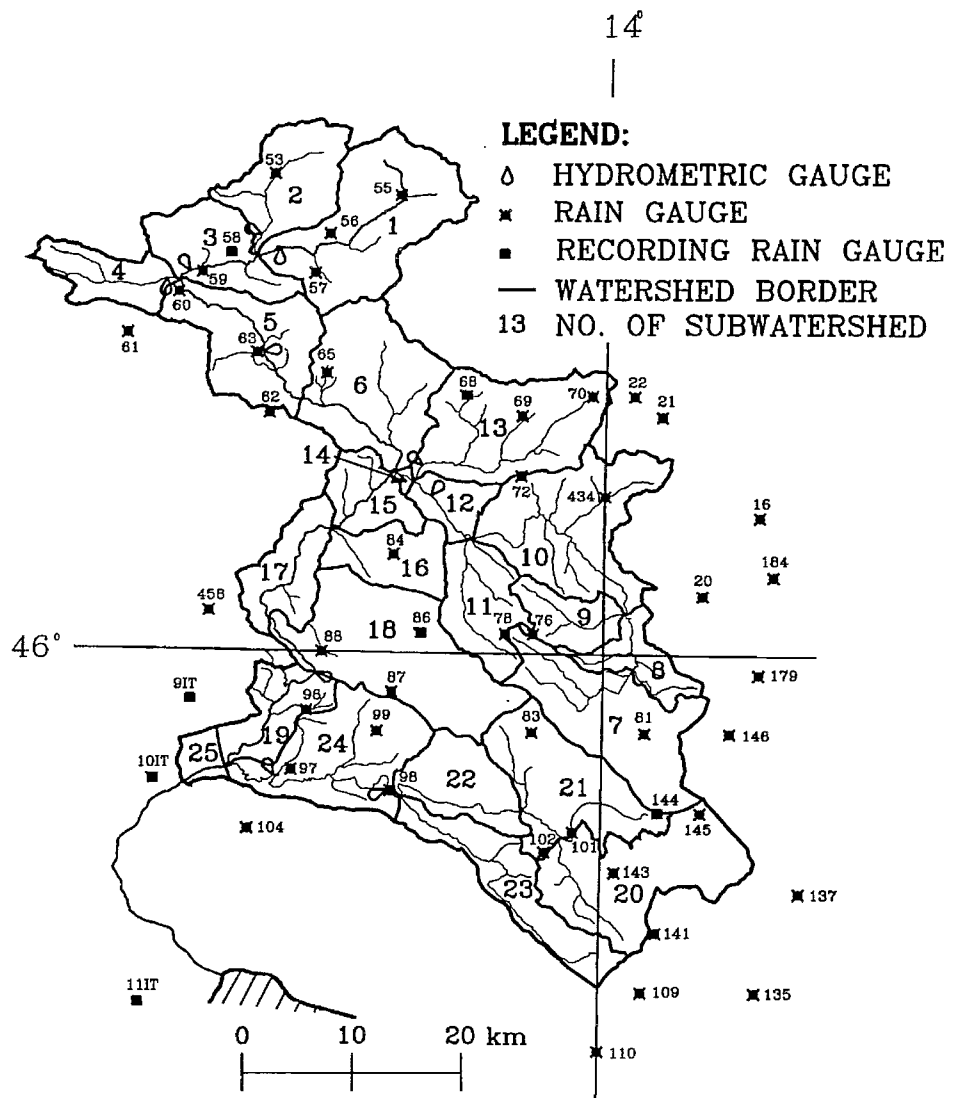

Figure 2 : The Soca watershed with sub watersheds, rainfall and rives gauging stations

Figure 2 : Le bassin et les sous-bassins du fleuve Soca, les stations hydrométriques et pluviométriques

2 Rainfall data collection and analysis

The Hydrometereological Institute had studied more than six floods during 1992 and 1993 year. We chose four heavy rainfall events: 31.08-02.09.1992, 16.11-18.11.1992, 21.10.-25.10.1993 and 14.12.-17.12.1993 for further investigation (15 days of heavy rainfall). The total rainfall of the investigated thunderstorms exceeded one hundred millimeters. Data were evaluated using the techniques for handling of space oriented data provided by Quick Surf, Excel, STAGRAPHICS Plus and Access software on a PC Pentium computer. Daily rainfall izohyetal maps were made and the space contained inside the sub-watershed contour was integrated.

*Table 1 : The sub-watershed data**Table 1 : Les données des sous-bassins*

SUBWATER SHED		ALTITUDE				MEASUREMENT RAINFALL mm				CORREL. COEFF.	
NUMBER	AREA sq.km	AVERAGE	MAXIMUM	MINIMUM	MAX - MIN	SEPTEMBER 92	NOVEMBER 92	OKTOBER 93	DECEMBER 93	Sub watershed 1	Sub watershed 10
1	166	1319	2680	387	2293	213	267	215	153	1,00	0,53
2	87	1268	2620	390	2230	208	253	183	112	0,98	0,52
3	76	1164	2525	335	2190	203	303	212	151	0,98	0,66
4	42	1995	2489	335	2154			208			
5	112	711	2212	198	2014	172	235	227	148	0,97	0,65
6	142	897	2230	152	2078	149	261	226	192	0,91	0,80
7	138	802	1475	333	1142	41	210	251	181	0,52	0,98
8	43	589	1040	305	735	37	217	226	158	0,55	0,98
9	45	709	1155	305	850	56	274	227	140	0,60	0,98
10	155	626	1560	179	1381	41	157	191	106	0,53	1,00
11	73	773	1476	182	1294	69	229	239	188	0,51	0,96
12	32	550	1033	150	883	86	273	207	189	0,60	0,97
13	144	793	1925	159	1766	86	233	196	174	0,68	0,95
14	3	350	1040	108	932	106	277	200	186	0,68	0,96
15	48	478	1040	108	932	101	259	190	163	0,67	0,94
16	57	702	1060	120	940	86	263	191	166	0,57	0,96
17	63	341	802	69	733	71	165	168	109	0,59	0,91
18	182	813	1465	57	1408	48	183	196	136	0,55	0,98
19	104	104	622	45	577	19	148	151	77	0,56	0,98
20	147	643	1277	97	1180	25	102	151	90	0,52	0,94
21	121	586	1334	84	1250	28	141	207	144	0,49	0,95
22	71	250	1241	58	1183	26	118	173	114	0,52	0,96
23	88	336	706	64	642	28	91	142	82	0,50	0,96
24	133	147	1150	50	1100	27	122	148	86	0,57	0,98
25	11	51	200	30	170	18	134	136	54	0,56	0,92

Rainfall is a statistically space distributed event. Many experiments have been undertaken to determine the accuracy of the point rainfall measurements. Errors in these measurements were usually caused by wind velocity, shape and position of equipment (Rodda 1967).

On large flat areas, where the rainfall cells are placed randomly, the data correlates well with the density of rainfall stations. In the mountainous areas, the orographic effect causes the movement of these rainfall cells effected by orography and leads to more rainfall at higher altitudes. The analysis of data from different regions shows the importance of inclination and aspect of a particular basin (Sevruck and Zahlavova 1994). The question is how to prove such an empirical relationship for a particular watershed and a particular rainfall event.

Daily rainfall data were calculated using isohyetal maps of the daily rainfall data produced by the daily measurements from 46 stations. The sum of the mean rainfall for a particular watershed used for analyzing thunderstorms is in Table 1. The daily rain gauge data and daily mean sub-watershed rainfall data were cross-correlated. From the results of the cross-correlation we could subdivide the watershed into two parts: an upper part hidden deeply in the mountains with peaks over 2500 m. (sub-watersheds 1 to 6, Figure 1) and a central and lower part at a moderately high altitude and, open to the southwest (sub-watersheds 7 to 25).

The correlation coefficients of the point rainfall gauge data from the upper part (8 rain gauges) of the watershed are from 0,99 to 0,88 (mean 0,933 and standard deviation 0,04) and for the central - lower parts from 0,99 to 0,43 (mean 0,823 and standard deviation 0,11). The correlation coefficients for the sub-watershed rainfall data from the upper part of watershed (40 rain gauges) are from 0,99 to 0,87 (mean 0,947 and standard deviation 0,04) and for the central and lower parts from 0,99 to 0,79 (mean 0,924 and standard deviation 0,05). The daily rainfall data for the sub-watersheds correlate much better than the point rain gauge data, especially in the central and lower parts of the watershed. The point oriented rain gauge data are more random and inaccurate than the space-integrated sub-watershed rainfall data. The daily rainfall in the upper part of the watershed correlated very well with the data from sub-watershed 1. Amongst the data from the central - lower parts of the watershed, sub-watershed 10 has the best correlation with the others (Table 1).

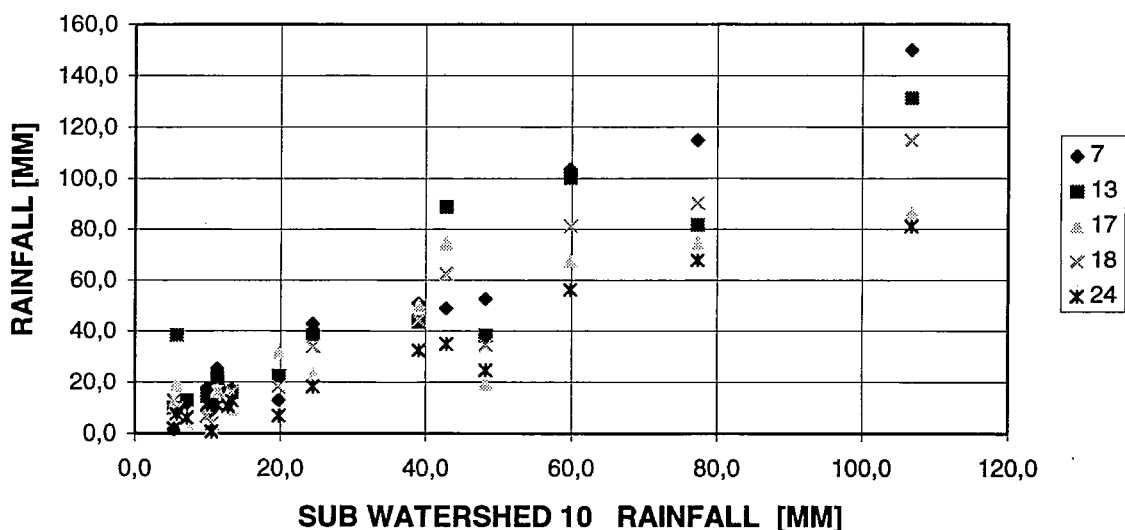

Figure 3 : Daily rainfall relations for sub watershed 10 and sub watersheds 7, 13, 17, 18, and 24
Figure 3 : Les relations entre les précipitations quotidiennes du sous-bassin 10 et celles des sous-bassins 7, 13, 17, 18 et 24

The daily rainfall data points are scattered randomly for rainfall amounts below 20 mm., while the heavy rainfall data points (over 50 mm.) are more regulars (Figure 3). Heavy daily rainfalls vary significantly between sub-watersheds a small distance apart or in a nearby valley. This is shown by the data for sub-watersheds 10 and 13 or 21 and 7 in Table 1. Orography influences the movement of heavy rainfall cells on almost same path and causes more precipitation at higher altitudes in the mountainous areas. In some parts of the watershed or in the valleys, flooding is more frequent than elsewhere.

3 Estimation of rainfall by linear regression

The question is : it is possible to estimate thunderstorm events wich produce heavy precipitation using only data from part of the watershed ? This question is related to the development of an on-line forecast and alarm model connected to rain gage and meteorological radar data.

We developed two models for the Soca River watershed. First one is for the upper alpine part of watershed, with correlation relationships between rainfall data on sub watershed 1 and sub watershed 2-6, and second one is for central - lower part, with correlation relationships between rainfall data on sub watershed 10 and sub watershed 7-25. A linear regression relationships between daily rainfall was estimated for the following thunderstorms: 31.08.-02.09.1992, 16.11-18.11.1992 and 14.12.-17.12.1993 (10 days). These models were tested for the thunderstorm from 21.10.1993 to 25.10.1993 (Table 2).

Table 2 : Daily rainfall for the thunderstorm on October 1993 with the absolute and relative errors of the linear regression model

Table 2 : Les averses quotidiennes d'orage en octobre 1993, avec les erreurs absolues et relatives du modèle de régression linéaire.

No. Of sub watershed	MEASURED RAINFALL					ABSOLUTE ERROR		RELATIVE ERROR	
	21.Oct	22.Oct	23.Oct	24.Oct	25.Oct	average	st.dev.	average	st.dev.
1	17,21	96,63	40,48	39,30	21,37				
2	12,92	87,27	29,26	34,07	19,12	-1,26	3,33	-0,02	0,11
3	16,83	102,51	32,58	44,11	16,09	-1,49	5,03	-0,08	0,16
5	18,81	98,00	40,74	45,79	23,81	6,47	6,90	0,11	0,07
6	21,84	94,08	40,35	44,90	24,50	22,61	5,10	0,60	0,20
10	13,34	77,30	48,28	38,99	12,83				
7	17,07	114,97	52,77	50,92	14,91	-4,49	7,42	-0,13	0,12
8	16,28	99,12	49,06	46,96	14,44	-7,99	8,05	-0,15	0,13
9	12,56	94,54	62,42	44,57	13,37	-16,15	13,97	-0,33	0,08
11	14,46	97,69	57,67	54,09	14,71	-11,34	4,59	-0,36	0,22
12	14,66	87,59	46,05	40,89	17,51	-25,34	14,59	-0,66	0,15
13	15,92	81,88	38,19	43,54	16,18	-19,05	9,99	-0,57	0,20
14	16,28	85,87	37,42	40,55	20,22	-27,98	17,00	-0,74	0,29
15	15,24	83,19	31,86	40,21	19,59	-24,23	15,09	-0,72	0,37
16	12,05	86,94	36,66	40,47	15,36	-24,39	13,55	-0,76	0,30
17	9,33	74,73	19,04	50,08	14,81	-6,95	14,68	-0,54	0,67
18	16,22	90,25	34,54	44,23	11,14	-6,16	9,36	-0,24	0,27
19	8,23	69,78	20,77	38,73	13,52	-2,17	11,17	-0,10	0,49
20	5,26	71,40	35,29	31,86	7,47	3,60	9,43	-0,17	0,45
21	19,50	95,53	41,42	38,68	12,02	2,19	9,27	0,02	0,18
22	26,69	79,94	30,11	26,25	10,38	2,49	12,09	0,02	0,33
23	19,43	65,74	25,08	23,47	8,47	3,37	9,24	0,07	0,28
24	12,77	67,81	24,69	32,44	10,54	-0,22	7,61	-0,01	0,27
25	10,06	57,40	18,00	34,35	16,27	0,55	10,00	0,02	0,49

For the sub-watershed daily rainfall data, absolute and relative error statistics are shown in Table 2. It is interesting that correlations for the central - lower parts are much better for sub watersheds far from sub watershed 10 than for the nearby sub watersheds (sub watersheds 9 - 16, Table 2). The relative error is lower for higher rainfall data, i.e. higher than 50 mm, (Figures 4 and 5).

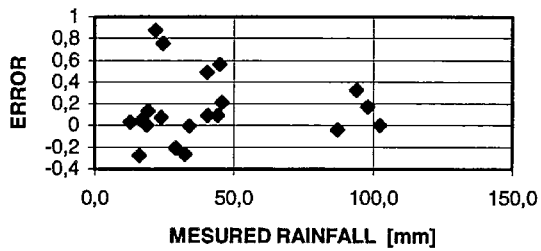

Figure 4 : *Relative error for the upper alpine part of the watershed*

Figure 4 : *L'erreur relative pour la partie alpine amont d' un bassin*

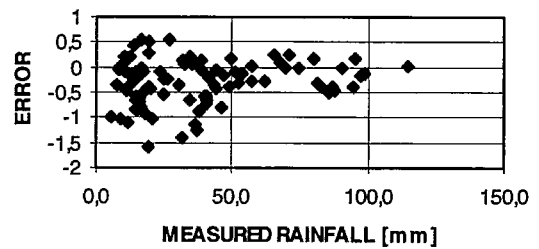

Figure 5 : *Relative error for central-lower part of the watershed*

Figure 5 : *L'erreur relative pour la partie centrale d'un bassin*

The data only fitted adequately in some sub-watersheds, although these correlations should be verified by taking new measurements. The final conclusion cannot be derived on the basis of only one rainfall event. Verifying the above results against additional more thunderstorms and relating them to hourly rainfall data will be the subject of the further investigations. The problem is how to choose representative rainfall stations for flood forecasting.

4 Conclusion

The orographic effect and its impact influence the movement of rainfall cells and cause more rainfall at higher altitudes in mountainous areas. Some sub-watersheds have more precipitation than others for large thunderstorms.

The daily rainfall data for watersheds correlate much better than the point rain gauge data. The sub-watershed related rainfall data are more representative and correlate better than the point measurements despite the accuracy of the point measured data. The linear regression between the different sub-watershed samples is better for high rainfall. The sub-watersheds rainfall data fit very well, with correlation coefficients greater than 0.9.

The daily sub-watershed rainfall data compare favorably for some of the sub-watersheds, but these relations should be verified by taking new measurements. A few rainfall events can only serve as a rough estimate for relations, but its results promise useful relationships.

Acknowledgements

Data support from the Hydrometeorological Institute (Ljubljana) and Centro Servizi Agricoli (Cervignano, Italy) was very helpful for our investigation. The Beta Studio (Padova, Italy) also helped us with data acquisition and analysis. The following results are part of the CEC Project: Storms, Floods and Radar Hydrology.

Meteorological conditions of heavy rains

Conditions météorologiques des pluies fortes

M.C. Llasat

1 Introduction

On 7 August 1996 a flash flood caused by sudden heavy rainfall completely destroyed a camp site situated in Biescas, Huesca (Spain), in the Central Pyrenees. Of a total of 630 persons registered at the camp site, 183 sustained injuries of greater or lesser seriousness and a further 85 died in less than 45 minutes. The closest pluviometric records show that the accumulated rainfall over the period was 169 mm. The camp site was situated between two small gullies which overflowed.

The foregoing is a clear example of flash flooding, a hydrometeorological event which depends upon both hydrological and meteorological factors and can be distinguished from ordinary floods by the short time-scale of the event. While other flood types occur over periods of several days and the damage can be mitigated, flash floods occur too fast for this, and the only hope for saving lives lies in having a good system for forecasting and issuing flood warnings. And such a system involves thorough knowledge of the phenomenon and all its implications, which in this case are mainly meteorological, hydrological and those relating to land planning. The Mediterranean area shows a predominance of flash floods over other types of floods such as those due to snowmelt or weak but highly persistent rains. In the course of the AMHY/FRIEND project it was found that this is the case in Italy, France and Spain, where rainfall has occasionally exceeded 400mm in 24 hours. The problem is found on a lesser scale in Greece, Yugoslavia and the other Eastern countries, where in many places levels of 100 mm in 24 hours are occasionally exceeded. In Rumania, for example, it is hardly surprising that the problem of flooding is more closely related with thawing.

There scarcely exists in the world a study of the climatology of floods, and still less of flash floods, and, when there is any such study of climatology, it usually relates to a very specific areas. The knowledge climatology of heavy precipitation events is more widespread and there are therefore more situations which can be analysed, classified and used to draw conclusions. In view of the fact that one necessary though insufficient factor for the occurrence of a flash flood is the existence of heavy rainfall, the study of floods inevitably involves gaining knowledge of the processes which cause this to occur.

2 Characteristics of convective systems and their relationship with heavy rains

Heavy precipitation is taken to mean occasions when high intensity rainfall is combined with a relatively long duration. In simple terms, the rainfall rate is the product of the flow of the water vapour mass multiplied by the efficiency of the precipitation. An event of high intensity can be due to a high water mass flux, a high precipitation efficiency, or both at once, with precipitation efficiency being taken to be the quotient of the water vapour which has entered the cell and the precipitation falling to the soil, integrated for the entire life cycle of the cell.

Although the concept of high rainfall rate can vary with the climatic characteristics of the rain for each location, the literature considers a high intensity to be that which exceeds 0.8 mm/min. (Rice and Holmberg, 1973; Dutton and Dougherty, 1979). In fact, not all precipitation of that intensity is convective, nor does all convective rain attain such an intensity. A study of Barcelona, Spain (Llasat and Puigcerver, 1985) reveals that 55% of annual precipitation is of convective character, while 37%

exceeds an intensity of 0.8 mm/min. Moreover, non-convective precipitation exceeding the said ceiling lasts for less than 0.001% of the time for which it is raining. In no case, however, was there rain of an intensity exceeding 3 mm/min which was not convective, as can be observed in Figure 1.

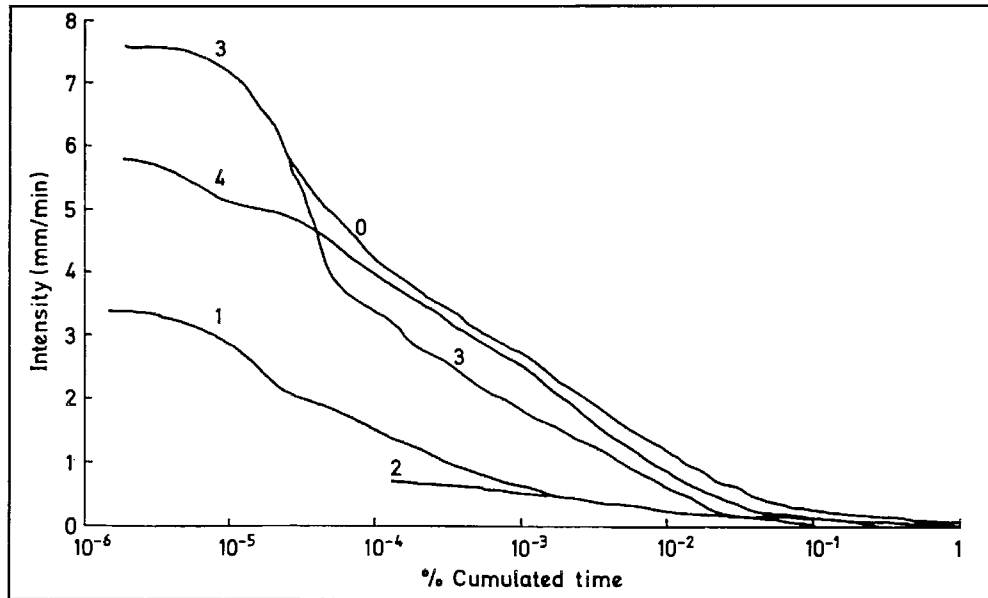

Figure 1 : Accumulated time distribution curves for the various categories of precipitation in Barcelona. 0: total precipitation, 1: non-convective precipitation, 2: convective precipitation with intensity <0.8 mm/min, 3: convective precipitation with intensity >0.8 mm/min, 4: precipitation associated with storms.

Figure 1 : Courbes de distribution cumulées pour différentes catégories de précipitations à Barcelone. 0: précipitation totale, 1: précipitation non convective, 2: précipitation convective avec intensité <0.8 mm/min, 3: précipitation convective avec intensité >0.8 mm/min, 4: précipitation associée à des orages.

The development of convection is generally due to one of the following causes (Jansa, 1990): air-mass discontinuities, cold fronts, stationary fronts, dry lines, sea and land breezes, emerging microfronts from previous storms, discontinuities of winds and river beds, secondary lows or cyclonic vortices. For convection to take place there must be vertical instability, a supply of humidity and forced ascending air. According to the scale on which these processes take place and the size of the convective system to which they give rise, the latter are classified as :

- meso- α : unicellular storms
- meso- β : severe pulsating storms, multicellular or supercellular ;
- meso- γ : mesoscale convective systems (MCS).

2.1 Unicellular storms

These storms are made up of a single cloud or cell which, at a certain stage of its development, has housed an ascending current and, later, a descending current. They extend horizontally for some ten kilometres or less and they last on average for less than one hour. It is possible to distinguish a development phase, characterized by general ascendancy; a phase of maturity which starts when the precipitation leaves the base of the cloud and which lasts for some 20 minutes ; and a dissipation phase characterized in that the descending currents extending throughout the entire cloud, which finally disappears when condensation ceases (Chisholm and Renick, 1971).

In the case of the flash floods which affect relatively small basins, the storms are usually unicellular, each with its own individual life cycle and passing one after another over the affected basin, constituting what could be termed a “train effect”. Such storms, in the course of their advance, reach the stage of maturity, and therefore their maximum intensity, over the same place, thereby accumulating a large quantity of rain over a short period. Sometimes these are what have come to be called quasi-stationary convective rain systems (QRS), characterized in that they are composed of different storm cells, at different stages, with practically no movement (Chappell, 1986). The movement of a convective storm is in fact the sum of an advection effect and another propagation effect. In the first, the convective storm is carried along as a body by the general flow. In the second, the convective storm of itself constitutes a process in movement produced by the dissipation of some old cells and the formation of other new ones on one flank of the preceding cells. When advection and propagation cancel each other out, the resulting movement is practically nil.

2.2 Multicellular storms

This is the most frequent type of storm. It can be considered to be made up of n cells, each cell having a lifecycle of its own and the storm extending horizontally between 30 and 50 km. The cell n develops from a mother cell into a daughter cell which after some 15 minutes is totally separate from the mother cell. Meanwhile the cell $n-1$, which shows maximum reflectivity on the radar, has reached the phase of maturity, with strong ascending and descending currents, while the cell $n-2$ is by then in its dissipation phase. Chisholm and Renick (1971) estimated that up to some 30 cells may form during the life cycle of a multicellular storm, each cell having a life cycle of some 45 minutes.

As in the above case, a QRS can be formed by multicellular storms. In the Mediterranean area the number of floods due to multicellular storms is considerably higher than those due to unicellular storms, since the latter, while they can attain considerable intensity, are usually of very short duration. This was the case in the rain recorded in Barcelona on 3 September 1972, during which event an intensity of 9.78mm/min (~600 mm/h) was reached, but only 65 mm in 24 hours were accumulated.

2.3 Supercellular storms

These storms can arise in the mature phase of a multicellular storm as a result of the high degree of organization of the convection within it. They have the appearance of a single-cell storm, but are more extensive and last longer, with an extensive plume (60-150 km in length) accompanied by a visible anvil 100 to 300 km in length extending leeward of the actual eye of the storm. Another of their main characteristics is the strong winds associated with them, sometimes with a highly significant rotation factor. This type has in fact usually been associated with severe weather (damaging convective winds, hail and tornadoes).

For many years it was believed that these supercells could not be related to heavy rains, given their scant precipitation efficiency. Indeed, the most characteristic phenomenon of supercells is the considerable evaporation which arises within them and which is fundamental to the formation of tornadoes (Doswell and Burgess, 1993). However, the extraordinary ascending currents which arise within a supercell mean that despite the efficiency being low, the rain generated can be so great as to cause flooding. Moreover, while the classic supercells associated with tornadoes move very quickly dragged by the strong wind around them, those associated with heavy rains move slowly due to the propagation effect (Charba and Sasaki, 1971), which tends to produce heavy rainfalls in a single area. This is particularly significant in the Mediterranean area, where the formation of tornadoes is considerably less frequent than that of heavy rains.

2.4 Mesoscale convective systems

Although the foregoing systems also fall into the category, the term Mesoscale Convective Systems (MCS) is usually reserved for highly organized systems of larger scale. Their cloud structure can be linear (tropical storms and squall lines) or practically circular (cyclones, Mesoscale Convective Complexes, MCCs), though it is possible that the meteorological radar shows a linear precipitation structure while the ceiling of the clouds has a nearly circular shape. The first studies were in fact made by Maddox (1980), who defined MCCs. It was only some years later (Houze et al., 1989) that MCCs were shown to be no more than the largest members of the overall spectrum formed by Mesoscale Convective Systems, MCSs.

A typical MCS structure is one which has most of the deep convection organized into a line running along the leading edge of the outflow. There is frequently a region of "stratiform precipitation" behind this line of deep convection. The passage of the system includes a relatively brief episode of heavy rain followed by another longer period of moderate rain. The combination of both components can give rise to rainfall of 200 mm or more, with a more or less balanced distribution between the "convective" part and the "stratiform" part. The synoptic situation can sometimes favour the passage of a succession of MCSs over a single area, giving rise to what might be termed a "super-train effect" in which each MCS would play the role of an individual cell. The passage of the first system would obviously leave the soil saturated, thereby increasing the possibility of floods arising due to the passage of the systems coming along behind it.

3 Factors necessary for the production of heavy rains

As stated earlier, not all convective storms are associated with the production of heavy rains. Firstly, a considerable quantity of water vapour must condense over a short period of time, and this means that the incoming air must contain a very high amount of humidity. Furthermore, a convective storm with a strong updraft means a water vapour mass flux higher than that of a convective storm with weak updraft. Both factors, humidity input and updraft, depend upon the environmental conditions in which the convection develops. At the synoptic scale these conditions are reflected in the quasi-geostrophic vertical forcing, moisture flow at low levels, convective instability and the convective available potential energy.

The quasi-geostrophic vertical forcing is calculated using the Q-vector formulation (Hoskins and Pedder, 1980; Doswell, 1985) to express the quasi-geostrophic omega-equation (Holton, 1971). The horizontal distribution of convective instability in the lower troposphere is determined by the difference between equivalent potential temperatures at 500 and 1000 hPa, where this type of temperature is defined as the temperature that a saturated parcel of air acquires when it evolves adiabatically and reversibly to a reference level (Bolton, 1980). Finally, the water vapour convergence in a layer close to the ground in the convective area is a necessary mechanism in supplying water vapour for sustaining convection. In this formulation the FQ is calculated from geopotential, wind, temperature and humidity on one or two isobaric surfaces which are normally used in operational work. Recent work on flooding in the Mediterranean Area has revealed how the conjunction of quasi-geostrophic vertical forcing at 850 hPa, the equivalent potential temperature difference between 500 and 1000 hPa and moisture convergence at 1000 hPa, determines the zone for which there exists a potential risk of heavy rains (Ramis et al, 1994, 1995; Llasat et al, 1996). Figures 2 and 3 clearly show these results. They pertain to 12 November 1988, when floods were recorded in Catalonia (northeast of the Iberian Peninsula) and in southern France (Llasat and Rodriguez, 1992), resulting from rainfall exceeding 200 mm in 24 hours.

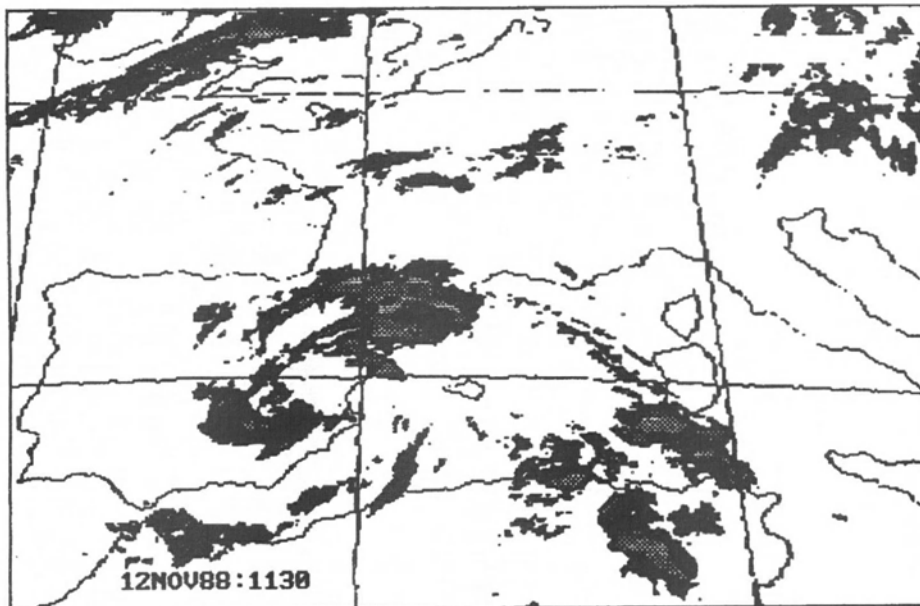

Figure 2 : *Meteosat IR primary image on 12 November 1988, at 1130 UTC.*

Figure 2 : *Image infrarouge brute de Météosat du 12 novembre 1988 à 1130 UTC*

It can be observed that the main cloud formation lies within the area of overlapping of the three factors outlined above (the time lapse between the two figures should be taken into account). It also illustrates that this condition, though necessary, is not sufficient, since there are zones in which the three factors are superimposed and yet no major cloud formations develop. The explanation for this could be sought in the topographical effect and in the CAPE.

Indeed, the updraft speed is very closely related with the Convective Available Potential Energy (CAPE) of the atmosphere, which forms part of the net buoyancy of the updrafting mass (Weisman and Klemp, 1986). The greater the mixing ratio of the inflowing air the greater the CAPE will be. Moreover, the maximum updraft speed can be related with the CAPE, so that a CAPE of 50 J/kg would mean an updraft speed of 10 m/s, which is moderate, while a CAPE of over 1500 J/kg could give rise to updraft speeds in excess of 50 m/s, at which speeds the quantity of water vapour which can be processed is very large.

Figure 3 shows how the CAPE evolved over the course of the above heavy-rain episode in Catalonia in 1988. Despite the fact that the radiosonde reading was taken in Palma de Mallorca, some 300 km to the SE of Catalonia, on 12 November at 12 UTC it reached 2257 J/kg. For the purposes of information, the same figure also includes the precipitable water mass. Other studies (Llasat et al, 1994) confirm that catastrophic rainfall episodes in the Western Mediterranean are usually associated with CAPE values exceeding 2000 J/kg.

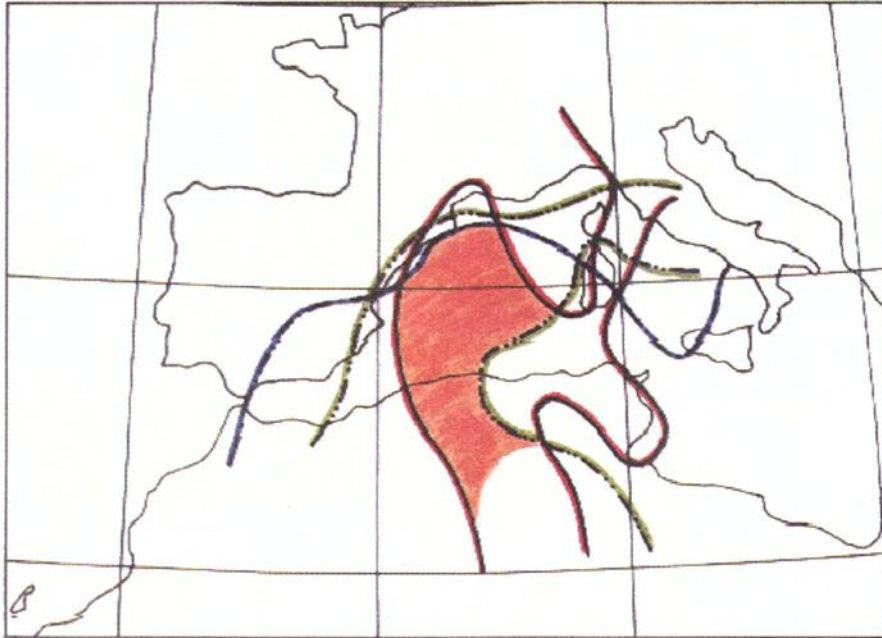

Figure 3 : Composite chart at 1200 UTC 12 November 1988. Green line $FQ=0$. Red line, zero line of equivalent potential temperature difference between 500 and 1000 hPa. Blue line, zero line of moisture convergence at 1000 hPa. Coloured zone denotes existence of the three forcing mechanisms.

Figure 3 : Carte composée du 12 novembre 1988 à 1200 UTC. Ligne verte, $FQ=0$. Ligne rouge, ligne correspondant à la valeur zéro de la différence de température potentielle équivalente entre 500 et 1000 hPa. Ligne bleue, ligne correspondant à la valeur zéro de la convergence de la vapeur d'eau à 1000 hPa. La zone colorée indique l'existence des trois mécanismes de forçage.

4 Conclusions

Flash floods, and in general most floods, are produced by heavy rains, that is, rains of high intensity which are also persistent. This implies that the flow of water vapour drawn by convection is considerable and that precipitation efficiency is high. But heavy rains can occur even where the efficiency is low (as in supercellular storms) or the intensity is moderate but persistent. Such a varied context of situations clearly makes the work of forecasters difficult. Furthermore, forecasters have to bear in mind the major role played by the previous precipitation and the attendant changes in the hydrological situation. Heavy rainfall concentrated in a small drainage basin can be more dangerous than when the same amount of rain is distributed over several basins or falls in a basin with considerable capacity for absorbing rainfall.

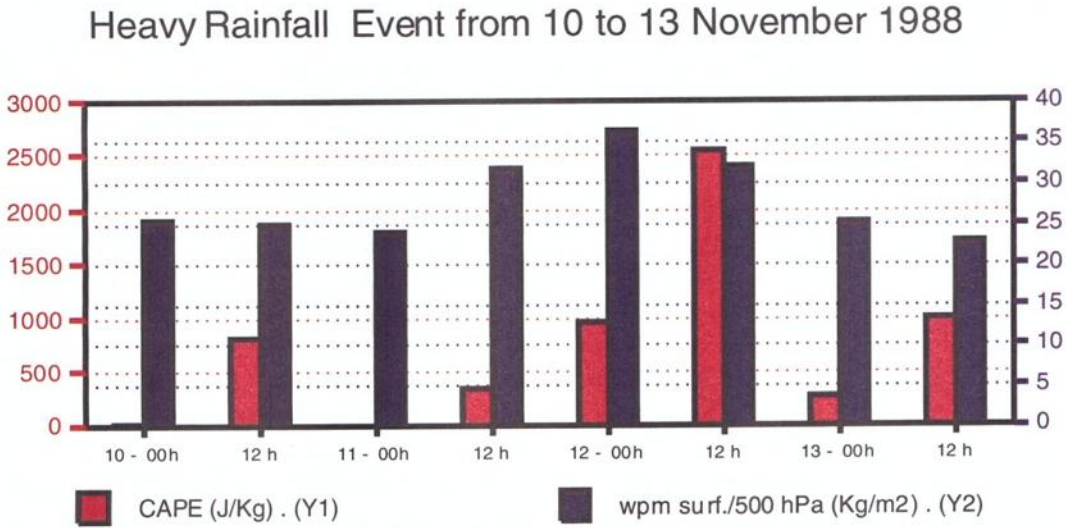

Figure 4 : Time evolution of CAPE and precipitable water mass in Palma de Mallorca during the November 1988 event

Figure 4 : Evolution temporelle du CAPE et de la masse d'eau précipitable à Palma de Majorque pendant l'événement de 1988.

Correct understanding of a heavy rain event necessarily involves a knowledge of cloud microphysics. But the absence of routine observations in the field of precipitation microphysics means that for the time being recourse has to be had to the tools currently available for operational forecasting, such as radiosonde observations and data provided by the various stations of the synoptic network and the models and forecasts made on the basis of same. The use of remote sensing (meteorological radar, meteorological satellites, etc), not only for estimating the pluviometric field but also for analysis of the internal structure of the convective system, is emerging as an essential tool. But there does not yet exist any methodical classification of the convective storms which affect the Mediterranean region and which takes account of their internal structure. The classification presented in section 2, though accepted throughout the scientific community, is based mainly on observations made in the United States and Canada. At present, within the context of the FRIEND project and, more specifically, AMHY/FRIEND, work is being done to draw up a base of information on the main heavy rain episodes in order, amongst other objectives, to be able to contrast the results and interpretations with those obtained in other regions of the world.

Although section 3 presents objective diagnostic tools such as the CAPE or those derived from the quasi-geostrophic balance, useful for the prediction of heavy rains, there is nevertheless one barrier which is difficult to surmount at present : the mesoscale. Indeed, the lack of data at the mesoscale and the scant knowledge of the main processes which govern it means that the operational models currently used are basically at the synoptic scale and generally do not take account of what might happen at the smaller scale. The most typical mesoscale models parametrize convection, but it would appear that there is still no parametrization which deals with convection suitably under all contexts. As a result, great changes are still needed in numerical prediction before the prediction of floods can be tackled correctly (Brookes et al., 1994).

Increased use of high-risk areas for recreation or human settlement nevertheless means that a disaster is increasingly invited. Commercial pressures when developing those zones are so great the dangers are, consciously or unwittingly, overlooked. The disaster which occurred in Biescas in August 1996 suggests, or rather reminds us, that it is not only a matter of prediction but of prevention. In the words of Doswell III (1993), "It is not a matter of whether flash floods will occur in such locations, it is only a matter of when and how bad. By building and vacationing in such places, the gamble is that the big

event will not occur during the time one is there. Perhaps this is a good calculated risk, but when the decision is made in ignorance, the danger is high that preparation will be minimal.”

5 Acknowledgements

I would like to express my thanks to the promoters of the FRIEND project of UNESCO, and especially to the international coordinator of the AMHY Group and to the CEMAGREF laboratory in Lyon, for the perseverance and dedication they made available at all times with a view to bringing the project through to a sound conclusion. I would also like to give thanks for the disinterested help of all members of the project, particularly all those working on the problem of heavy rains, for thanks to them it will be possible to find out on a regional scale the various aspects relating to such episodes. My acknowledgement to Ll. Martínez for making ready the final version of this chapter.

My thanks to the Spanish and French committees of the PHI of UNESCO, to the CICYT, project AMB95-0671-C02-02 and to the European Union, FLOODAWARE (ENV4-CT96-0293) project, which provided the necessary resources without which my team's collaboration in the project would not have been possible.

Mapping of statistical characterization of heavy rains at national scale

Cartes de caractérisation statistique des pluies fortes à l'échelle nationale

J. Ferrer Polo

1 Introduction

The making of maps to show the spatial distribution of rainfall at a certain probability level is one of the decisive phases in the use of hydrometeorological methods to obtain design floods, independently of the complexity of these methods. In particular, the application at the national scale of the modified rational method (MRM) (Témez, 1991), included in the Spanish drainage regulations, requires this spatial distribution as a basic input for the daily rainfall maximums (Pd) associated with a return period, which aspect was taken up by Ferrer and Ardiles (1994) within the framework of the FRIEND-AMHY Project. This paper undertakes an analysis of the methods habitually used, with special attention given to the above-mentioned study.

Estimates of the Pd value corresponding to a specific return period T, usually called quantiles, on the basis of a continuous series of records, can be tackled by statistical modelling of annual maximum series (AMS), threshold series (POT) or time series (TS).

The use of stochastic TS models is justifiable only in cases in which a marked time correlation is perceptible and nonfulfilment of the independence hypothesis rules out the use of AMS or POT. Comparisons between POT and AMS are usually based on the work of Langbein (1949), which shows how the results obtained differ notably only for short return periods. Except in the case of very short samples, this factor has led to more frequent use of the operationally simpler AMS models in analysis of maximums frequencies.

2 Statistical modelling of AMS

The statistical modelling of AMS requires (Cunnane, 1987) a joint choice of: a) distribution function model; b) parameters and quantiles estimation method; c) schemes for the combined use of local, regional and historical data, as applicable. Although considerable attention was at first devoted to choice of the distribution function model (Benson 1968), most research work from the 1980s onwards focused on the use of regional analysis techniques and of historical information in order to improve the estimation of parameters by reducing the variance of the estimated quantiles.

The following may be cited as distribution function models used in work at the national scale :

- a) general extreme value (GEV) (NERC, 1975), which includes Gumbel as one particular case ;
- b) log-Pearson III (LP3), (USWRC, 1981), which includes the lognormal (LN2) as a particular case ;
- c) two-component extreme value (TCEV), (Rossi et al., 1984), or the product of two Gumbel distributions ;
- d) SORT-ET_{max}, maximum of the exponential of the square root, a model proposed specifically by Etoh et al. (1987) for the analysis of maximum daily rainfalls and used by Ferrer and Ardiles (1994) in mainland Spain. Always more conservative than Gumbel, this model has the advantage of parsimony of parameters, being defined as a function of a scale parameter (α) and a shape parameter (k), this latter determining both the coefficient of variation (C_v) and the skew coefficient (C_s) (Fig. 1), so that there is a fixed relationship between C_v and C_s .

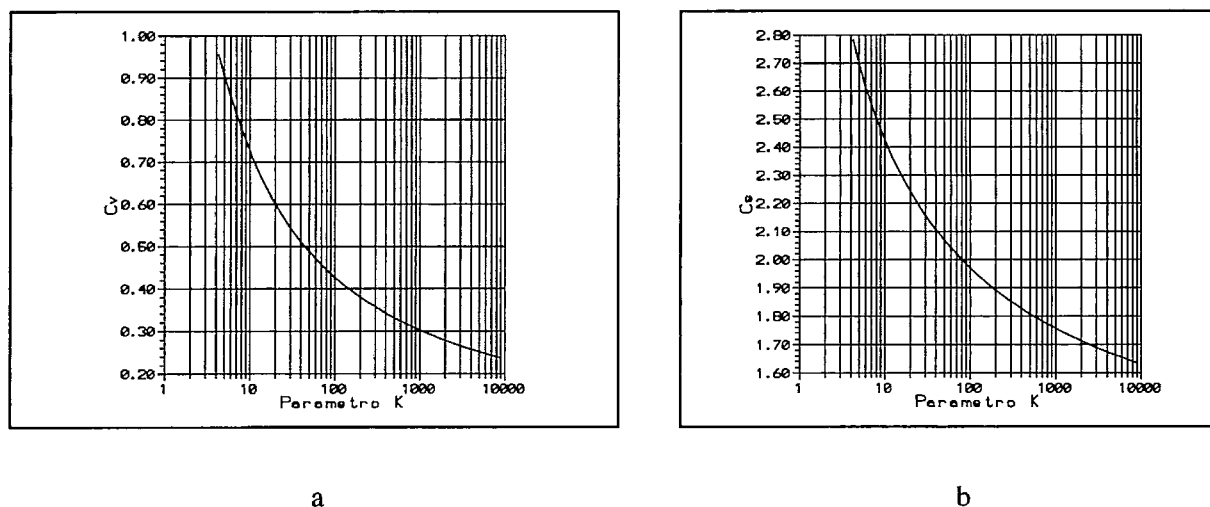

Figure 1 : Values of C_v (a) and C_s (b) in function of parameter k or the $SQRT-ET_{max}$ model (Ferrer, 1996)
Figure 1 : Valeurs du C_v (a) et du C_s (b) en fonction du paramètre k du modèle $SQRT-ET_{max}$ (Ferrer, 1996)

3 Parameter and regional estimation methods

Any method of estimation of parameters like moments (MOM), maximum likelihood (ML) or probability weighted moments, when applied to a single sample, presents difficulties due to uncertainty about the representative nature of that sample, which similarly shows itself in a high variance of estimates of the parameters and quantiles. This variance, all the greater the shorter the series is and the higher the skew coefficient (C_s) of the population, has led to the development of many methodologies which assume the existence of a region homogeneous with respect to certain statistical characteristics, thereby permitting use of the overall information available in that region. The most important phase in these methods lies precisely in definition of the "homogeneous" region, a subject to which section 5 will be devoted.

In the light of the "regionalized" statistical characteristic, we can discern - in ascending order of the homogeneous hypothesis - the following approaches :

a) regional C_s

Given the great sampling variability of the C_s , most of the methods seek to regionalize it in some way. One common procedure for regional estimation by MOM consists in deriving the mean regional C_s , arithmetic or weighted according to the number of years in the series, of the local values of the C_s in the zone considered (USWRC, 1981). Regional estimation of parameters by ML calls for prior standardization of each series, by adoption of the station-year hypothesis, and the final use of the overall data as a single sample (Rossi et al., 1984).

b) regional C_s and C_v constant in each subregion

This approach, termed hierarchical, is based on the different response of the moments as their order increases: mean, C_v , C_s , The high-order moments are difficult to estimate on the basis of one sample due to their high sampling variance, though they do show broader regional responses. The lower-order moments, on the other hand, are estimated more reliably on the basis of one sample, being responses to local causes which are difficult to regionalize. This situation leads to the positioning of different degrees of regionalization in the different moments, which in practice leads to regions being considered as having a constant C_s containing subregions within them, in which the C_v likewise remains constant. The hierarchical approach is habitually used with the TCEV model (Fiorentino et al., 1987).

c) regional C_s and C_v

These methods are termed "index flood" (or more correctly, "index variable"), and assume that the variable resulting from dividing the values noted in each season by a local scale factor follows the same frequency distribution throughout the region. It is an extreme case of the hierarchical approach, in that it assumes that only the mean is a response to local effects, while the higher-order moments, C_v and C_s , are the result of regional action. The section which follows is devoted to this question.

4 Index variable methods

4.1 Background

These methods had been used by Dalrymple (1960) in flood analysis, though they were subsequently brought very much into question, basically in relation to the independence of the C_v with respect to the size of the basin. This problem, which has not been confirmed in recent applications of the method (FRIEND, 1989), has not prevented the "index variable" method being the most widely used regional method following its application at national scale in Great Britain (NERC, 1975), both for flows (index flood) and for rains (index rain). In the analysis of rains the aforesaid doubt is not raised and the index rainfall method is the one most widely used in current work (Reed, 1992).

The local scale factor generally used is the sample mean, so that the variable and result of dividing by their mean the values noted in each station j : $y_{ij} = x_{ij} / \bar{x}_j$, follows the same frequency distribution Y_T throughout the region. The parameters of Y_T are derived from the overall series data, while the value of y_{ij} is obtained from the data for each season. Once the quantiles of Y_T have been obtained, the local quantiles are estimated by

$$x_{Tj} = \bar{x}_j - y_T \quad (1)$$

4.2 Obtaining the regional distribution y_T

The regional quantiles y_T can be estimated in various ways :

- a) Regional mean of the local quantiles, estimated by MOM, ML or PWM, standardized in advance through their mean: x_T/\bar{x} (Dalrymple, 1960). Another similar approach consists in averaging out regionally the local parameters related with the C_v and obtained locally (Arnell and Gabrielle, 1988).
- b) Estimation of parameters by MOM, using the regional mean of the sample values of the various adimensional moments in function of the number of parameters of the selected model. Regional estimation of the C_v , such as that carried out by Ferrer and Ardiles (1994) with the SQRT-ET_{max} model (Fig. 2) is sufficient for 2-parameter models. With 3-parameter models, a regional mean of both the C_v and the C_s is needed.

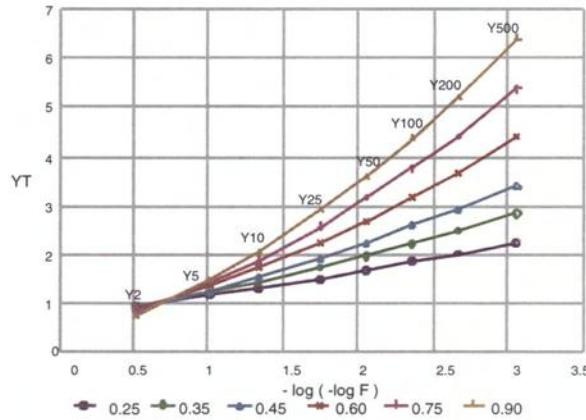

Figure 2 : *Quantiles y_T of the SQRT-ET_{max} model as function of the C_v (Ferrer and Ardiles, 1994)*
Figure 2 : *Quantiles y_T du modèle SQRT-ET_{max} comme fonction du C_v (Ferrer et Ardiles, 1994)*

- c) Adoption of the "station-year" hypothesis, standardizing the values of each station j by means of their quotient by their local mean and considering the overall data as a single series (NERC, 1975).
- d) Estimation of parameters by PWM, using the regional mean of the sample values from the various adimensional PWMs, in a similar way to b). This method was popularized by Hosking et al. (1985) with the GEV law and has been widely used since then. Ferrer (1996) recently applied this method with the SQRT-ET_{max} model, which requires exclusively the adimensional PWM of order 1 (m_1) in order to obtain the shape parameter k (Fig. 3), with a smaller RMSE being found in the quantiles estimates.

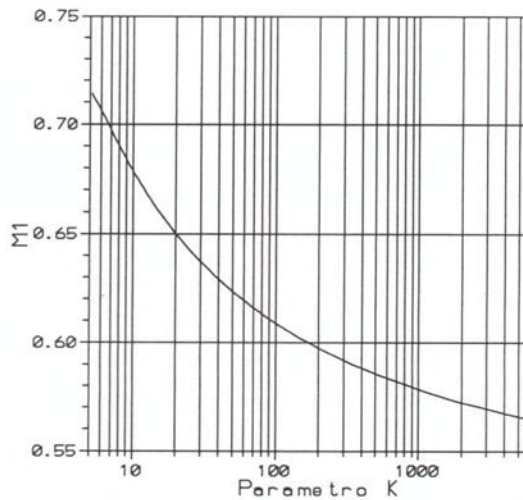

Figure 3 : *Relationship between m_1 and k in the SQRT-ET_{max} model (Ferrer, 1996)*
Figure 3 : *Relation entre m_1 et k dans le modèle SQRT-ET_{max} (Ferrer, 1996)*

4.3 Obtaining the local scale factor

The local scale factor, usually the mean, can be estimated at the site of a meteorological station by means of the AMS sampling mean, though it has to be extrapolated to points without records. Two types of procedures are used :

With the current state of knowledge there exists no procedure which permits correct definition of the region for analysis of hydrological maximums.

Any method of grouping stations for subsequent regional analysis of the whole must in practice meet two conditions: a) achieve relatively homogeneous groups and b) permit assignment of a certain number of points without data to a previously defined region.

These conditioning factors mark the three types of "spaces" into which the delimitation of regions was implemented: a) geographical; b) statistical characteristics (FRIEND, 1989) and c) specific characteristics (Acreman and Sinclair, 1986).

In the treatment of rains, however, there is a clear predominance of the geographical regions which facilitate assignment of a point without pluviometric records to a certain region, though they usually raise problems of regional homogeneity. As an example of work at national scale, Ferrer and Ardiles (1994), Spain is divided into 26 geographical regions.

In respect of regional homogeneity, it is common to take the concept of "statistical" homogeneity and to adopt an χ^2 test regarding the nul hypothesis which postulates that all the region's series have the same value as the regionalized statistic. The test proposed by Wiltshire (1986) was adopted by Ferrer and Ardiles (1994), while that drawn up by Wiltshire and Beran (1987 b) was used in FRIEND (1989). The traditional focus of regions with precise limits raises the difficulty of delimitation in real applications and can be objected to on the grounds of discontinuity of the results within said limits. Both questions have been tackled in practice by: a) weighting scheme (Wiltshire and Beran, 1987 a) which assigns to the point a certain combination of the results from each of the "closest-lying" regions, thereby making the limits less abrupt and reducing errors due to erroneous assignment, and b) definition of regions formed by the stations as a whole closest to the point analysed (Reed 1992). In Ferrer and Ardiles (1994), within a context of regional estimation of parameters by MOM, recourse was made to a weighting scheme which made the limits of C_v less abrupt in the various regions by means of spatial interpolation of the 26 regional values (Fig. 5).

6 Conclusion

The statistical characterization of maximum rainfalls is mostly approached by means of statistical modelling of AMS, which calls for the model to be chosen in function of distribution and of the method of estimation of parameters, which in its turn includes the schema for combined use of local and regional data.

The schema most widely used is the one termed "index variable", which assumes a single adimensional law within the region which is rescaled by means of a local factor.

For pluviometric analyses the most common approach is the use of geographical regions whose homogeneity is usually compared and contrasted by means of statistical tests and whose limits are usually rendered less abrupt by means of weighting schemes or by using regions centered upon the point under study.

The adoption of a two-parameter distribution function model, such as the SQRT-ET_{max} model (Etoh et al., 1987), allows the regional law to be expressed as a function of a single parameter. Within a scheme of estimation of parameters by MOM, this permitted Ferrer and Ardiles (1994) to synthesize the results by means of: a) a national-scale map (Fig. 5) of C_v in isolines obtained by weighting of the regional values, and b) a relationship between C_v and the regional quantiles (Fig. 2).

The local scale factor, usually the mean of the AMS, generally calls for the use of spatial interpolation techniques such as the kriging and graphic representation of the final results in the form of isolines (Fig. 4).

Finally, the GIS is clearly useful for obtaining and presenting the final results. In the setting of a simple raster GIS such as IDRISI (Eastman, 1992 a, b), Ferrer and Ardiles (1994) obtain the layer of regional quantiles (Figs. 2 and 5) and the layer of the local scale factor (Fig. 4) at a spatial resolution of 2,500 m, thereby permitting spatial application of expression (1).



Figure 5 : *Isolines of the regional value of C_v (Ferrer and Ardiles, 1994)*
Figure 5 : *Isolignes de valeur régionale de C_v (Ferrer et Ardiles, 1994)*

e

Application of weather radar in mountainous basins

Application des radars météorologiques aux bassins versants montagneux

Z. M. Radic

1 Introduction

A significant progress in meteorology has been made with weather radar during last fifty years, and with weather radar applications in operational hydrology during the last twenty years (WMO, 1995). This was made possible with introduction of computerised radar systems in late sixties. After initial enthusiasm when it was thought that weather radars will become a substitute for ground rain gauging stations, numerous problems were encountered related to errors in estimation of rainfall depth and intensity. Later, some methods were developed for automatic compensation of these errors so that a realistic rainfall estimates can be made, especially when radar data are combined with data from ground rain gauges and meteorological satellites.

Application of radar in hydrology has gone through several phases, while the real benefits have been noticed only recently with the development of distributed hydrologic models combined with the geographical information systems (GIS) methodology. These approaches permit inclusion of rainfall spatial distribution and dynamics in runoff model, so that a simulation can be made together with radar data before the storm reaches the basin. This is especially important for operational hydrology, since the methods for spatial forecasting are still under development.

Some results of a study on radar application in mountainous basins in Yugoslavia will be presented in brief. Mountainous basins are specific because the rain gauges are usually sparse and spatially non-uniform storms are dominant. There are a few examples of this type of radar applications in literature available to the author. For example, Flahaut et al. (1991) developed a very efficient system for correction of errors in radar data from mountainous regions and for average catchment rainfall estimates based on combination of radar and ground data; Bras (1988) developed a complete methodology for real-time flow forecasting in which weather radar data are coupled with a subsurface flow model based on digitized geomorphological data, and Borga et al. (1991) semidistributed model for flood forecasting in mountainous basins.

2 Radar meteorology in Serbia

Weather radar are present in hydrometeorological service in Serbia from 1969. Their first purpose was hail suppression. In the 1970-1978 period, there was approximately 27,000 announcements of storms. By 1980, a network of 13 weather radars is established, which was at the time one of the densest radar networks in Europe with 66,000 km² per radar.

Hydrologic applications of weather radar started in mid-seventies, and intensified in early eighties with introduction of the radar data processor (RDP) computerised system and a range of application software (weather radar data processing - WRDP). Figure 1 presents an example of results from the Belgrade weather radar (Ericson RDP and WRDP).

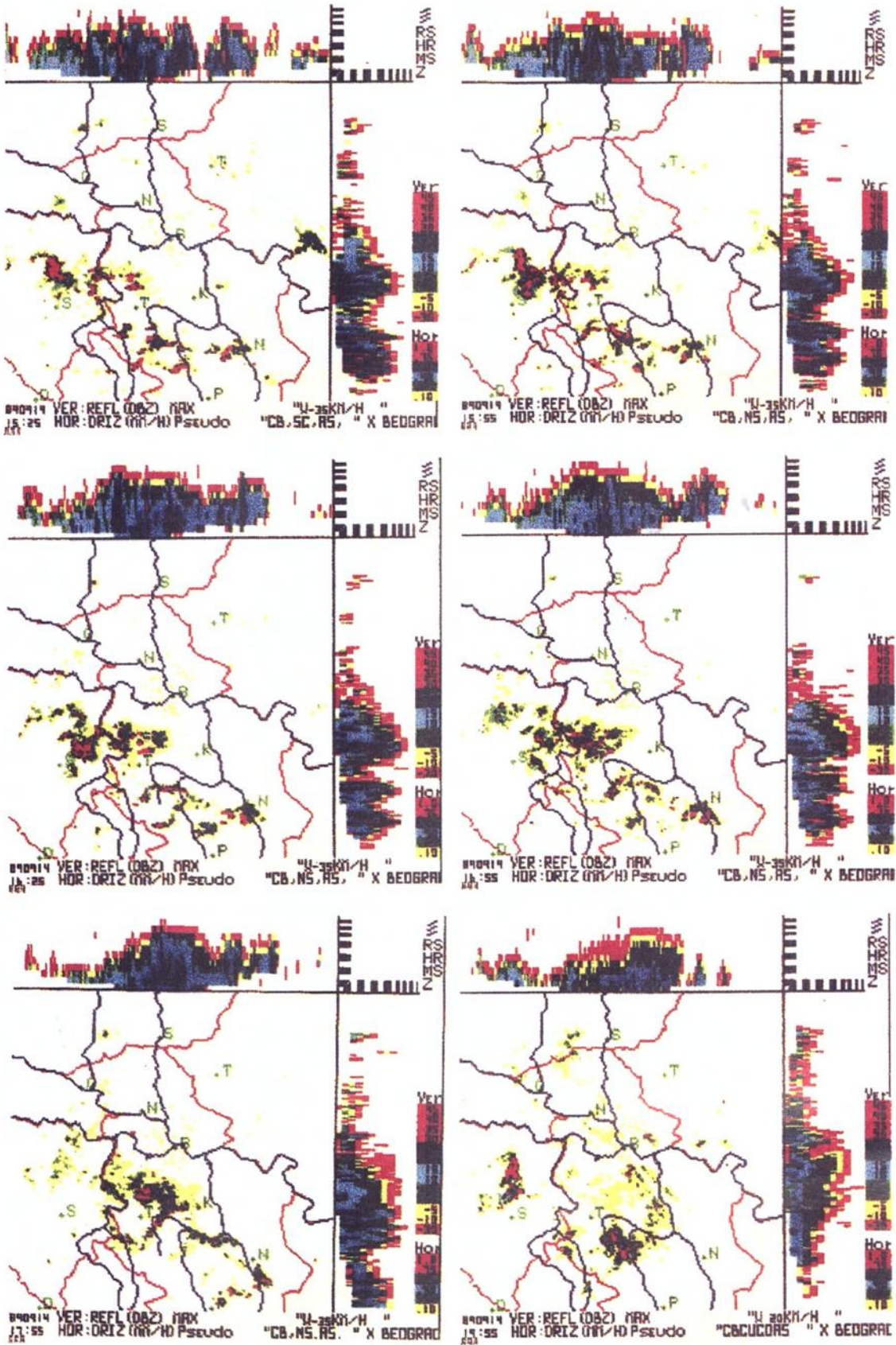

Figure 1 : Development of a storm above the Drina catchment

Figure 1 : Le bassin versant de la rivière Drina : évolution du système pluvieux au cours d'un épisode

3 Introduction of weather radar in hydrology

Republic Hydrometeorological Service of Serbia established in 1975 an experimental polygon in the river Kolubara basin. The basin is located within the 70 km range from the weather radar in Belgrade (Figure 2). Total basin area is approximately 1000 km². The basin is predominantly mountainous (elevation from 100 to 1350 m a.s.l.). Principal achievements of the study on possibilities of weather radar applications in hydrology are:

- knowledge on the level of accuracy in radar rainfall measurements;
- calibration of the radar equation parameters;
- definition of correction factors for cloud type, signal attenuation, bright band, ground clutter, reflectivity etc.

It was important for this phase that the techniques for calculating average basin rainfall were developed. Most operational hydrological models before 1985 were based on lumped approach which requires only the average rainfall depth over the basin in certain time intervals.

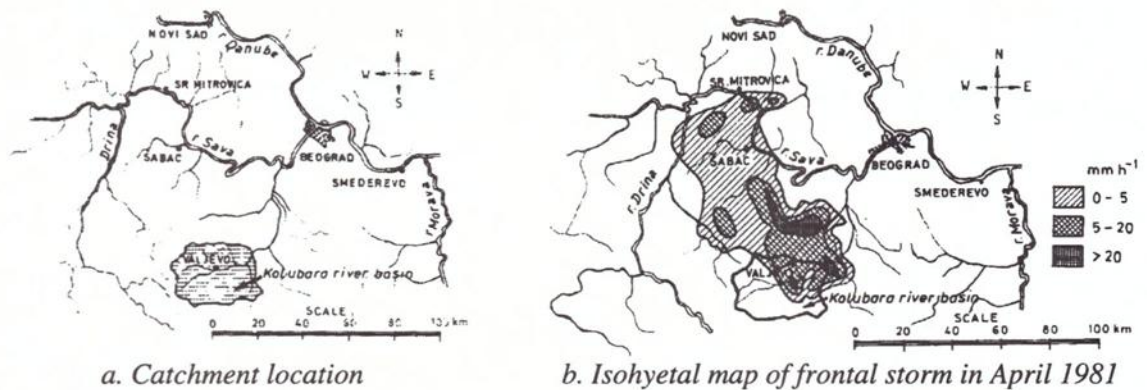

Figure 2 : Kolubara river catchment

Figure 2 : Le bassin versant de la rivière Kolubara

4 Influence of storm dynamics on runoff hydrograph

Investigation of the effect of different rainfall and basin characteristics, based on data from laboratory catchment in Belgrade (Radic, 1978, 1989) and some other laboratory catchments, have shown that rainfall spatial distribution and dynamics have major influence on runoff hydrograph. This was a reason for development of adequate rainfall-runoff models. A simple quasi-distributed conceptual model was developed, based on isochrones and linear reservoir concept (ILR model, Jovanovic and Radic, 1981), and a fully distributed model DILR (Radic, 1982) which enabled detailed analysis of the effect of rainfall spatial distribution and storm dynamics on runoff hydrograph from rural and urban catchments. Figure 3 presents some of the results of simulation of moving storms in the Kolubara basin (Jovanovic et al., 1983).

The simulations were performed with the ILR model, using typical storm models defined from radar measurements. Since the catchment is relatively small (approximately 1000 km²), it was assumed that storms gradually cover parts of the catchment between isochrones or cover the whole catchment.

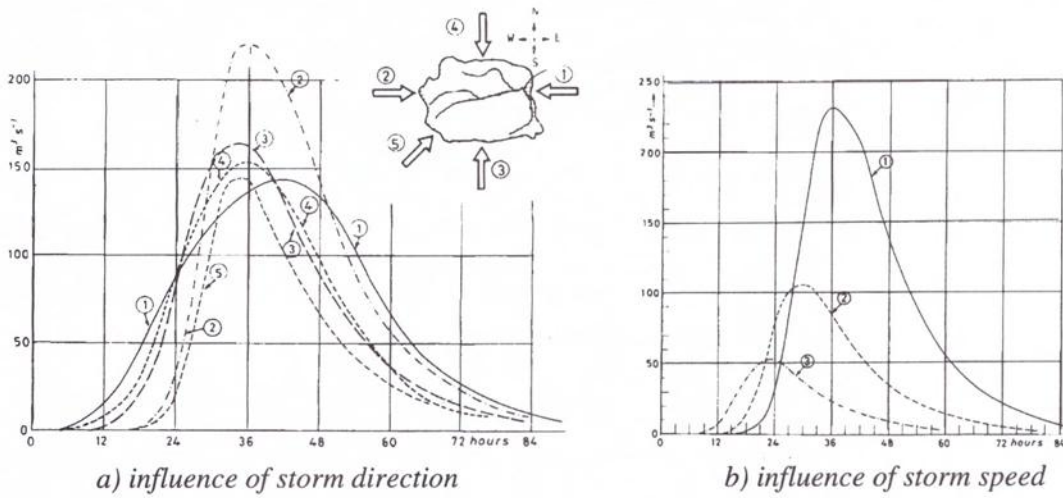

Figure 3 : Effect of storm dynamics on runoff hydrograph

Figure 3 : Les effets dynamiques des orages sur le ruissellement

5 Regional analysis of storm characteristics

Development of a hydrological information system for the Drina river was a motivation for development of a distributed adaptive model for flow forecasting in real time (Radic and Jovanovic, 1987). Since the Drina river basin is large catchment, rainfall spatial distribution and storm dynamics have a significant effect on runoff hydrograph. A separate study (Radic et al., 1989; Radic, 1994) was undertaken to analyse storms over the Drina basin from weather radar data (see Fig. 4 and 5). This kind of analysis enables definition of storms with different probability of occurrence, coverage, storm direction, velocity etc.

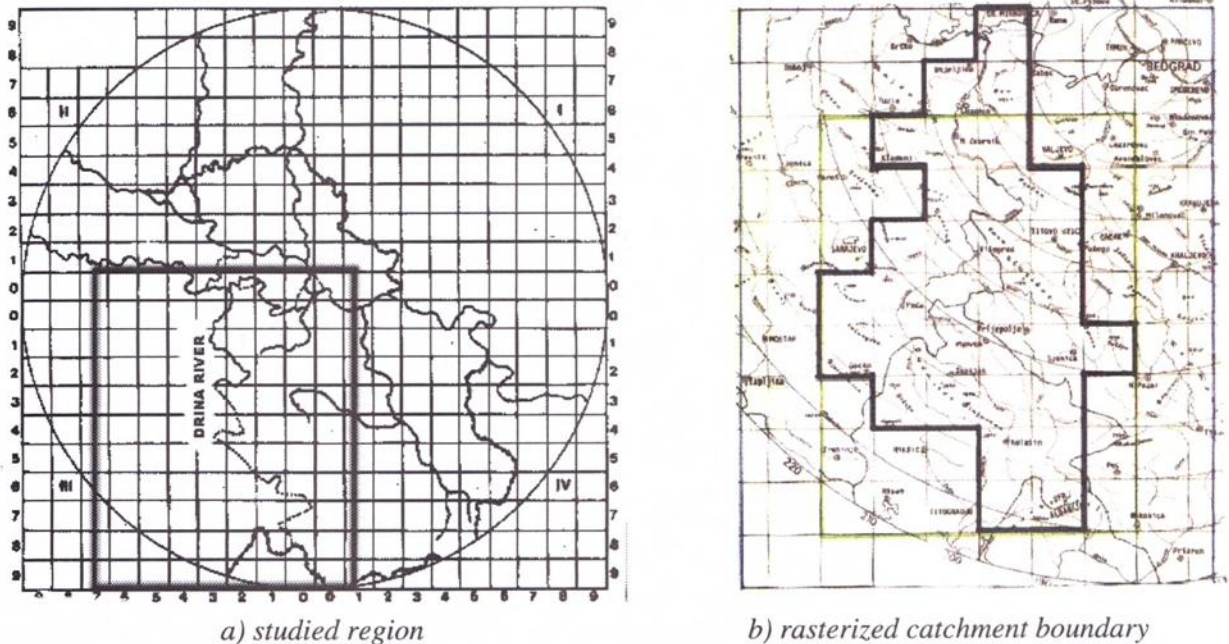

Figure 4 : The Drina river basin

Figure 4 : Le bassin de la rivière Drina

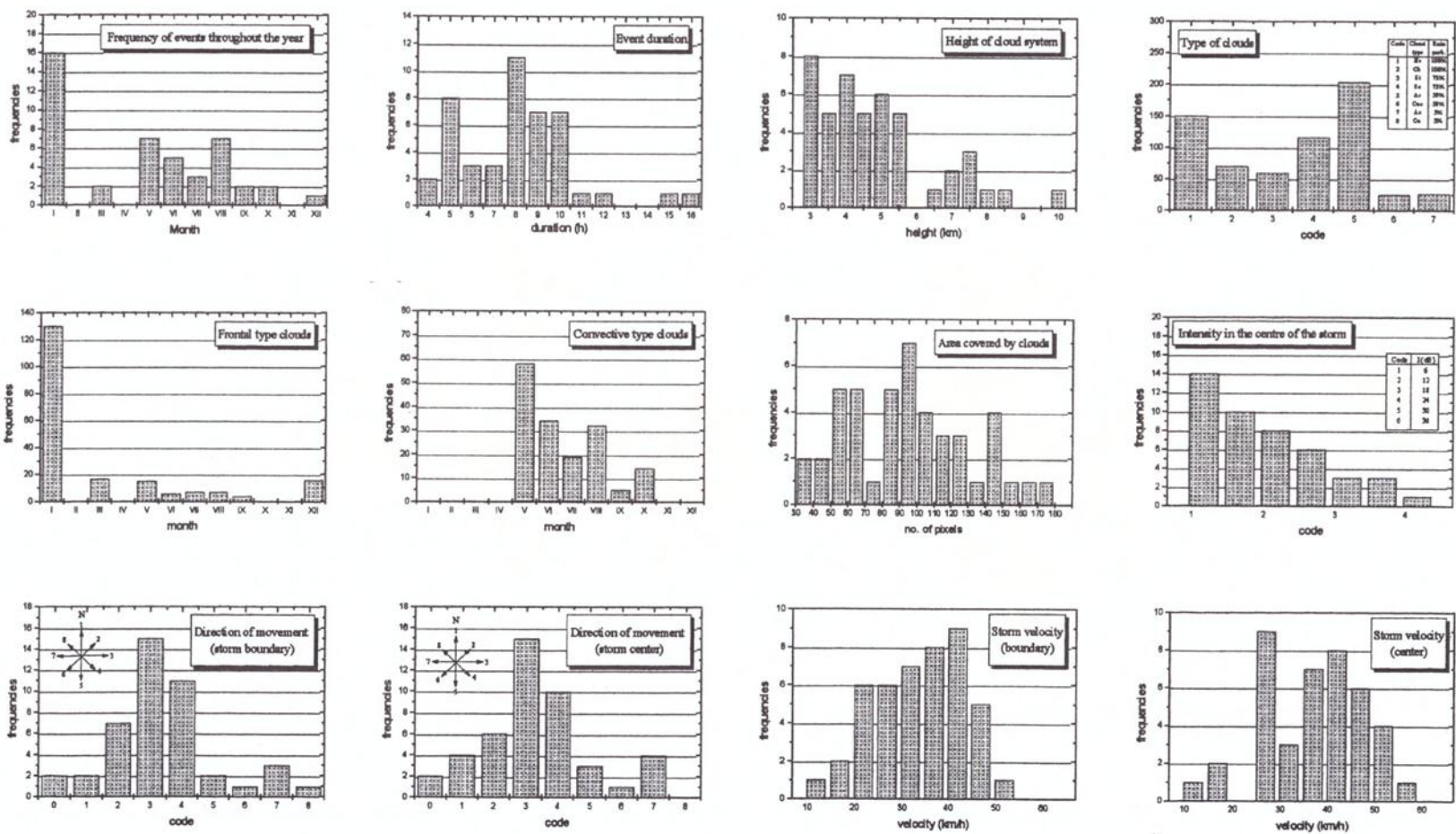

Figure 5 : Storm characteristics in the region of Drina basin analysed from radar data
 Figure 5 : Les caractéristiques des orages dans le bassin de la rivière Drina, obtenues par le radar

Runoff simulations with observed storms showed that the simulations are sensitive to changes in parameters of the Z-R relationship ($Z = aR^b$). Fig. 6 illustrates the effect of the parameters a and b in Marshall-Palmer relationship (Radic, 1994).

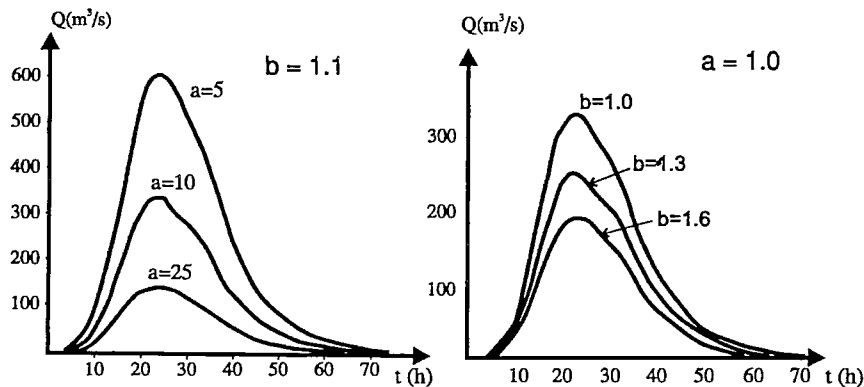

Figure 6 : Influence of the parameters in Marshall-Palmer relationship to runoff

Figure 6 : L'influence des paramètres dans l'équation Marshall-Palmer sur le ruissellement

6 Runoff simulations based on radar data and DILR model

A simulation and real-time forecasting procedure was developed (Radic, 1987, Radic and Petrovic, 1989) which enables direct linking of radar data with DILR model. Input data for the DILR model and storm characteristics are formulated on grid, so that runoff simulations based on radar data are possible in real time. For constant storm velocity a technique is developed which enables runoff simulation for realistic storm type coming from any of 8 principal directions. This enables runoff to be simulated before the storm reaches the basin. The same methodology can be applied to simulation of runoff from observed storms.

These simulations suggested an idea (not yet implemented) that the radar echo - rainfall intensity relationship can be calibrated using observed runoff hydrographs, provided that the runoff model is well calibrated.

The study on possibilities for weather radar application in the river Drina basin showed that additional consideration of rainfall spatial distribution is necessary, especially relationship between rainfall and topographic and orographic characteristics, as well as development of appropriate spatial interpolation method. An extensive study in this direction was performed (Petrovic and Radic, 1994). Another study was performed on possibilities of assessment of rainfall spatial distribution combining data from ground rain gauge stations and Meteosat (Petrovic and Elgy, 1994).

7 Conclusions

Applications of weather radars in hydrology have created possibilities for better and more reliable analysis of rainfall temporal and spatial distribution, and for runoff simulations.

First goal of this paper is to illustrate new possibilities for regional analysis of rainfall spatial distribution and storm dynamics. The other goal is to bring attention to the need of introduction of hydrological runoff models which take into account the effect of storm movement on runoff hydrograph.

It has been pointed out that a possibility exists for direct correction of rainfall through a complex runoff models (provided that the model is well calibrated).

For the flow forecasting purpose, an efficient procedure is developed in which radar data organized in raster form and are linked to the DILR conceptual model through a GIS. This enables runoff at small catchments to be simulated before the storm reaches the catchment. For larger catchments runoff can be simulated using rainfall spatial distribution observed with radar.

In the calibration phase of the model development it is necessary to have extensive and reliable measurements during a relatively short period, so that later better performance (concerning quality and efficiency) of the model can be expected.

It is obvious that all possible applications of weather radar are not thoroughly investigated and that further developments, especially together with GIS technology, are yet to be achieved.

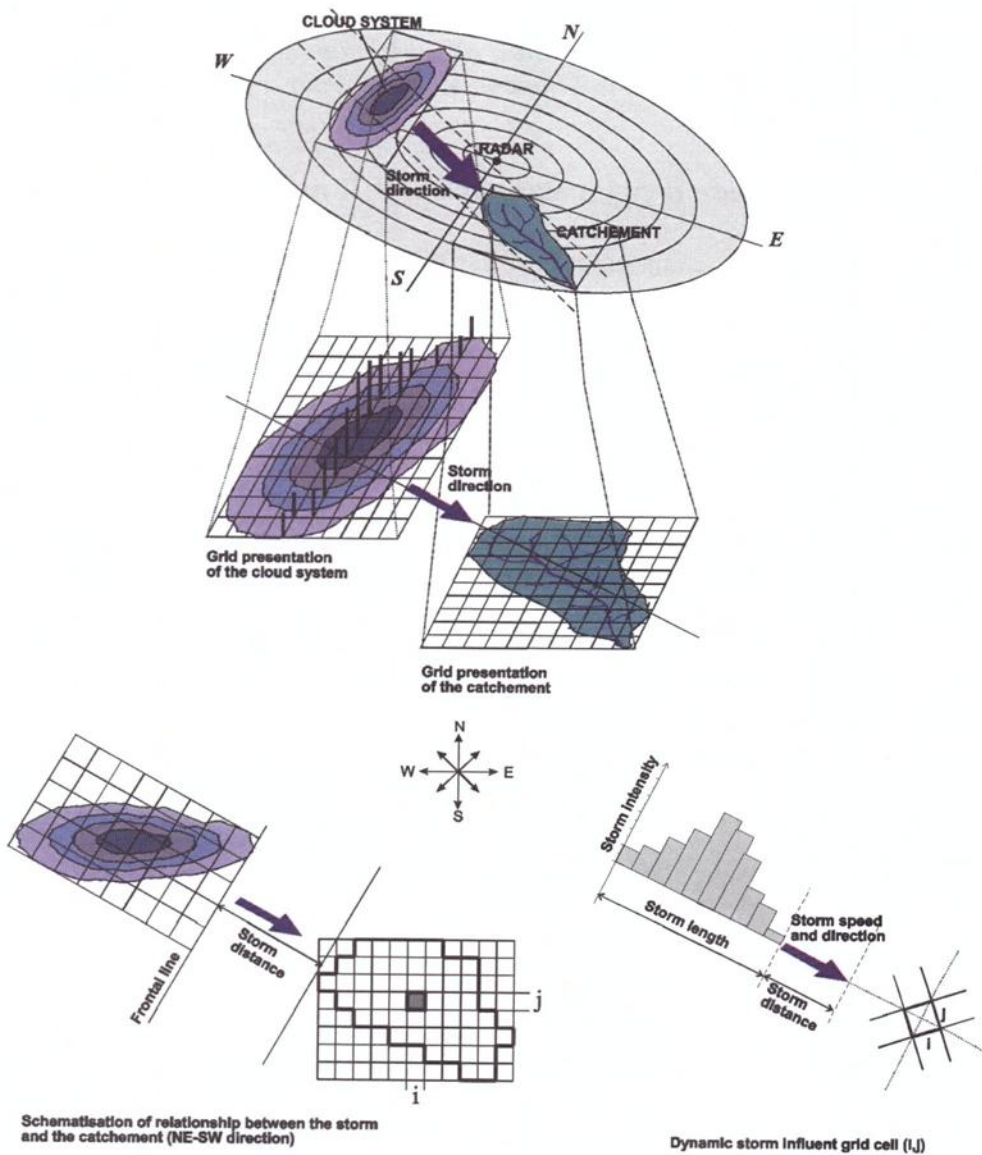

Figure 7 : Link between DILR model and radar data

Figure 7 : Le modèle DILR adapté pour l'introduction des données obtenues par le radar

Stochastic point models of rainfalls and their extremes

Modèles stochastiques ponctuels de pluies et de leurs extrêmes

G. Iritano and E. Ferrari

1 Introduction

The increasing number of disastrous phenomena caused by heavy rains grew the interest toward the study of rainfall behaviour. A reliable protection from flooding and landslide events could be reached through two different approaches: a structural approach, that is the realization of infrastructures of active protection, in order to decrease the possibility that the feared phenomenon occurs, and a not structural approach, whose objective is mainly the preannouncement of the event occurrences, in order to avoid the loss of human life and to reduce the economic damages. These protection strategies could even be performed jointly.

Stochastic models play a fundamental role in the preannouncement of disastrous events. Inside these models, a conceptual difference can be made between *purely interpretative* and *physically based* models. Briefly it can be said that the purely interpretative models try to reproduce the main characteristics of autocorrelation observed in the time series. On the contrary, the physically based ones hypothesize a physical schematization of the rainfall generation and usually they are built upon stochastic point process, so they are also indicated as *stochastic point models of rainfall*. An important feature of these models is their capability in reproducing the behaviour of extremes values, that is surely one of the most important aspects in the prevention of natural disasters.

In the following paragraphs various stochastic point models of rainfall are described and analysed, with particular regard to their properties of extreme.

2 Stochastic schematization of rainfalls

2.1 General formulation

Rainfall intensity process shows for long periods zero values and only for short periods positive values. A physically based stochastic model of rainfall should be able to reproduce this intermittence. Usually this is performed through models based on marked point process.

To build a generic stochastic rainfall model, a first part has to reproduce the rainfall generation mechanism. This part consists of a point process that identifies, on the time axis, the instant in which a rainfall occurs. In the following we will refer to this part as *occurrence process*. A second part of the model tries to model the duration, the form and the intensity of the precipitation, and it will be indicated in the following as *storm model*. Inside this general scheme, different kinds of physically based stochastic models can be built.

From an analytical point of view, stochastic point models of rainfall can be schematized as follows. Let $N(t)$ be the counting process of rainfall occurrence and $X_{t_k}(\tau)$ the rainfall intensity at time $t_k + \tau$ of an event beginning at time t_k (fig.1). The rainfall intensity process at time t is:

$$Y(t) = \int_{\tau=0}^{\infty} X_{t-\tau}(\tau) dN(t-\tau) \quad (1)$$

and the rainfall aggregated process on an interval Δt :

$$A_{\Delta t}(t) = \int_{t-\Delta t/2}^{t+\Delta t/2} \left(\int_{\tau=0}^{\infty} X_{s-\tau}(\tau) dN(s-\tau) \right) ds \quad (2)$$

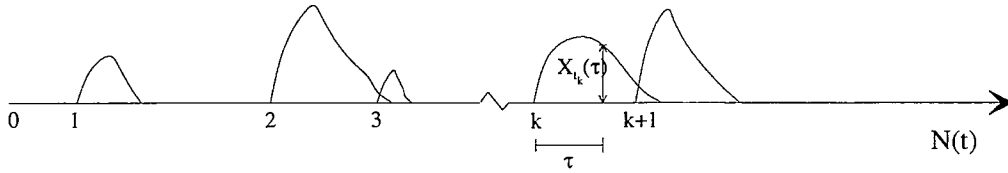

Figure 1 : Schematic representation of rainfall intensity process

Figure 1 : Représentation schématique du processus d'intensité des pluies

To infer on stochastic process (1) using the rainfall amounts data, the characteristics of aggregated process have to be known.

The different combinations of the occurrence processes and storm models give origin to different stochastic point models of rainfall. In the next paragraphs the most common models employed for occurrence and storm processes will be briefly described.

2.2 Occurrence schematization

Rainfall occurrence of rainfalls is schematized through one or two level processes. The most used one level process is Poisson, characterized by the intensity λ (time^{-1}). In this model the number of storms in a time interval τ is a discrete variable R with the following mass probability function:

$$p_{R,\tau}(r) = \frac{(\lambda\tau)^r e^{-\lambda\tau}}{r!} \quad \lambda > 0; \quad r = 0,1,2,\dots \quad (3)$$

The most diffused two level processes are Neyman-Scott and Bartlett-Lewis, both based on Poisson cluster processes (Cox and Isham, 1980; Daley and Vere-Jones, 1988). In Neyman-Scott process (Kavvas and Delleur, 1981) each storm is characterized by an integer random number of bursts, B . This latter is distributed as Poisson (Rodriguez-Iturbe et al., 1984; Obeykesera et al., 1987) or geometric law (Rodriguez-Iturbe et al., 1987a). In the former case the mass probability function is:

$$p_B(b) = \frac{v_b^{b-1} e^{-v_b}}{(b-1)!} \quad v_b > 0; \quad b = 1,2,\dots \quad (4)$$

while in the latter case it is:

$$p_B(b) = \theta_b (1 - \theta_b)^{b-1} \quad 0 < \theta_b < 1; \quad b = 1,2,\dots \quad (5)$$

The localization of the bursts on the time axis is schematized through a random variable, W , representing the waiting time between cluster centre and single burst occurrence, distributed according to an exponential law with parameter β_w (time^{-1}):

$$F_W(w) = 1 - e^{-\beta_w w} \quad \beta_w > 0; \quad w > 0 \quad (6)$$

Differently from Neyman-Scott, in Bartlett-Lewis process the variable W represents the interarrival time between two consecutive bursts. Moreover the first burst occurrence is coincident with the cluster centre (Rodriguez-Iturbe et al., 1987a).

2.3 Storm schematization

The most diffused storm schematizations are instantaneous and rectangular form of the rainfall. The first kind, called *white noise*, assumes a rainfall amount H concentrated in the rainfall occurrence time. Usually for H is adopted an exponential distribution, characterized by the parameter, β_h (length⁻¹),

$$F_H(h) = 1 - e^{-\beta_h h} \quad \beta_h > 0; \quad h > 0 \quad (7)$$

More generally for H can be adopted other distributions (i.e. gamma, Eagleson, 1978; mixture of two exponential distributions, Sirangelo, 1994).

The second kind of schematization, called *rectangular pulse*, is based on the hypothesis that each storm is formed by a rectangular rainfall. Intensity I and duration D are independent random variables, both distributed with an exponential law (Eagleson, 1972) characterized respectively by the parameters β_i (time/length) and β_d (time⁻¹).

Other approaches modify the previous hypotheses by proposing for the intensity a Weibull distribution (Cowpertwait et al., 1996) and for duration a Pareto distribution (Rodriguez-Iturbe et al., 1987b).

Some different approach simulates the storm by a triangular form (Marien and Vandewiele, 1986), or a rectangular form characterized by mutually dependent intensity and duration (Bacchi et al., 1994). Finally Sirangelo (1992) suggests for the storm a Beta distribution, that includes as particular cases rectangular and instantaneous pulses.

3 Some stochastic point models of rainfall

3.1 Poisson White Noise model

The stochastic model based on Poisson process for rainfall occurrence and instantaneous pulse model for storm depth is called Poisson White Noise model (PWN). In this model the rainfall amounts cumulated on a prefixed time interval Δt are independent and identically distributed random variables. Their common probability density function (pdf) can be derived from the total probability theorem:

$$f_{A_{\Delta t}}(a) = e^{-\lambda \Delta t} \left[\delta(a) + \sum_{n=1}^{\infty} \frac{(\lambda \Delta t)^n}{n!} f_H^{(n)*}(a) \right] \quad f_H^{(n)*}(0) = 0; \quad a \geq 0 \quad (8)$$

where $f_H^{(n)*}(\cdot)$ is the n -fold autoconvolution of pdf of variable H .

The cumulative distribution function (cdf) of $A_{\Delta t}$ can be derived by integrating the expression (8) :

$$F_{A_{\Delta t}}(a) = e^{-\lambda \Delta t} \left[1 + \sum_{n=1}^{\infty} \frac{(\lambda \Delta t)^n}{n!} \int_0^a f_H^{(n)*}(x) dx \right] \quad f_H^{(n)*}(0) = 0; \quad a \geq 0 \quad (9)$$

In the most simple version of PWN, variable H is distributed by an exponential law with parameters λ and β_h . A schematic representation of PWN model is shown in fig. 2.

The moments of the aggregated process can be obtained by the theory of Poisson processes (Parzen, 1962). The parameters estimation can be performed both with method of moments and maximum likelihood method, by using a sample of rainfall amounts aggregated on an interval Δt (Sirangelo and Versace, 1990).

3.2 Poisson Rectangular Pulse model

The Poisson Rectangular Pulse model (PRP) schematized the rainfall occurrences by a Poisson process and the storm by a rectangular pulse (fig.3). This model can reproduce the autocorrelation characteristics observed in time series since the variables $A_{\Delta t}$ are dependent among them. Different versions of the model can be obtained by choosing different distributions for intensity and duration of storm.

The parameters estimation of PRP model is obtained through method of moments by equating theoretical and sampling values of mean, variance and autocorrelation of lag 1 of $A_{\Delta t}$ (Rodriguez-Iturbe et al., 1984, 1987a).

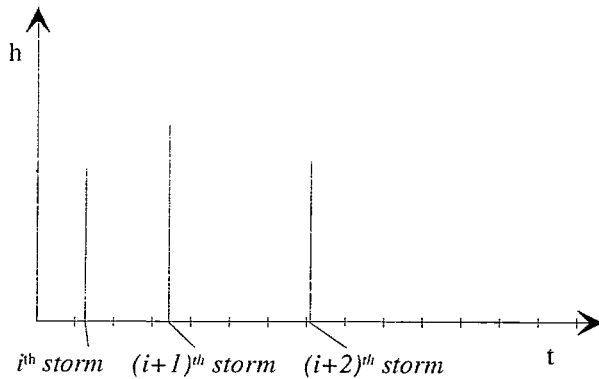

Figure 2 : Scheme of PWN model

Figure 2 : Schéma du modèle PWN

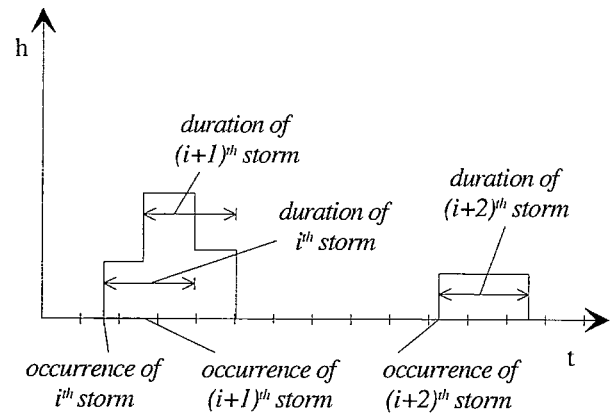

Figure 3 : Scheme of PRP model

Figure 3 : Schéma du modèle PRP

3.3 Neyman-Scott Rectangular Pulse model

Neyman-Scott Rectangular-Pulse model (NSRP) schematizes occurrences by a Neyman-Scott model and storms by a rectangular pulse (fig. 4). NSRP model has five parameters: λ , θ_b , β_w , β_d and β_i . Entekhabi et al. (1989) modified NSRP model, by considering β_d variable from storm to storm and distributed according to a gamma law.

The parameters estimation of NSRP model can be performed with method of moments by equating theoretical and sampling values of mean, variance and autocorrelation of lag 1,2 and 3 of random variable $A_{\Delta t}$ (Rodriguez-Iturbe et al., 1987a).

3.4 Bartlett-Lewis Rectangular Pulse model

Bartlett-Lewis Rectangular-Pulse model (BLRP) schematizes occurrences by a Bartlett-Lewis process and storms by rectangular pulse. BLRP model has five parameters: λ , θ_b , β_w , β_d and β_i . A schematic representation of the model is shown in figure 5. A modified version of BLRP model (Entekhabi et al., 1989) considers the parameter β_d variable from storm to storm and distributed according to a gamma law. The parameters estimation of BLRP model is based on method of moments (Rodriguez-Iturbe et al., 1987a, 1987b; Onof and Weather, 1994; Khaliq and Cunnane, 1996).

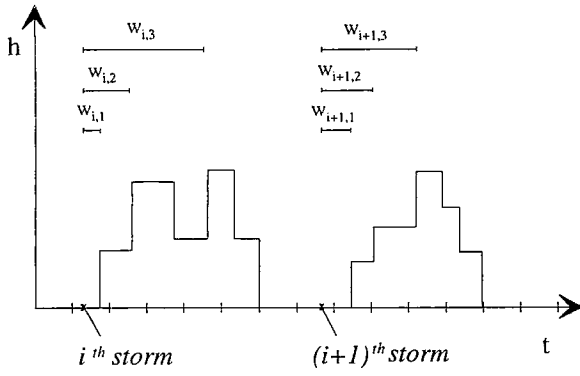

Figure 4 : Scheme of NSRP model
Figure 4 : Schéma du modèle NSRP

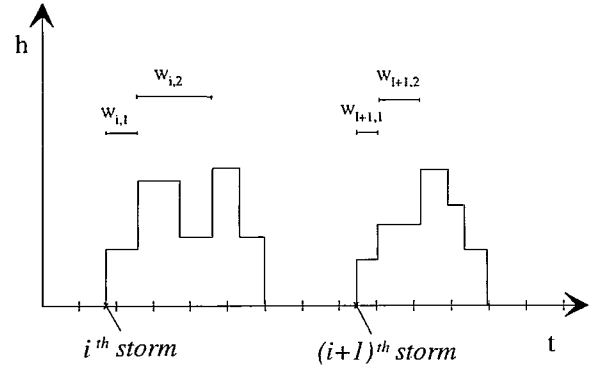

Figure 5 : Scheme of BLRP model
Figure 5 : Schéma du modèle BLRP

4 Extremes of stochastic models

The analysis of extreme rainfalls properties is of considerable interest from an applicative point of view. Evidently the complete knowledge of the stochastic rainfall generation mechanism should make possible the derivation of the probabilistic distribution of extreme rainfalls. This is true from a theoretical point of view, but in practice this possibility is strongly limited by the analytical complexity of stochastic rainfall models.

Among the models described above, the probabilistic distribution of extremes can be derived analytically only for the simple PWN model.

For this model, in fact, rainfall amounts on an interval of amplitude Δt are random variables independent and identically distributed with common cdf expressed by (9). Therefore the distribution of annual maxima (AM) could be expressed in the form:

$$F_{AM}(x) = \Pr\left[\text{Max}_{t_0} A_{\Delta t} < x\right] = \left[F_{A_{\Delta t}}(x)\right]^{t_0/\Delta t} \tag{10}$$

being $t_0 = 1$ year.

Substituting the cdf of $A_{\Delta t}$ into (10), the expression of cdf of annual maxima is obtained:

$$F_{AM}(x) = e^{-\lambda t_0} \left[e^{\lambda \Delta t} - \sum_{n=0}^{\infty} \frac{(\lambda \Delta t)^{n+1}}{n!(n+1)!} \Gamma(n+1, \beta_h x) \right]^{t_0/\Delta t} \tag{11}$$

where $\Gamma(a, x) = \int_x^{\infty} e^{-t} t^{a-1} dt$ is the incomplete gamma function.

An approximated expression of (11) can be derived when the interval amplitude Δt is so small that the probability to have two or more storms in the same interval vanishes. This probability is equal to $1 - e^{-\lambda \Delta t}$ and obviously tends toward zero when Δt vanishes. Under this restrictive hypothesis the cdf of annual maxima can be derived by the classic theory of marked point process. In fact, being the rainfall occurrences a Poisson process, the occurrence of peaks over threshold, for a generic threshold x_0 , is a Poisson process too. Its intensity is $\lambda[1 - F_H(x_0)]$ (Cox and Isham, 1980), where $F_H(x_0)$ is the non exceedance probability of the threshold x_0 . So the cdf of annual maxima can be easily derived by the relationship (Todorovic, 1978):

$$F_{AM}(x) = \exp\left[-\Lambda(1 - F_{POT}(x - x_0))\right] \tag{12}$$

where $\Lambda = \lambda t_0 [1 - F_H(x_0)]$ is the mean number of peaks over threshold per year and $F_{POT}(\cdot)$ is peaks over threshold distribution. $F_{POT}(\cdot)$ is related with the distribution $F_H(\cdot)$ through the simple relationship:

$$F_{POT}(x - x_0) = 1 - \frac{1 - F_H(x)}{1 - F_H(x_0)} \tag{13}$$

that, substituting into (12), gives:

$$F_{AM}(x) = \exp[-\lambda t_0 (1 - F_H(x))] \tag{14}$$

Being $F_H(x)$ exponential, the approximated form of (14) is a Gumbel law:

$$F_{AM}(x) = \exp\{-\exp[-\alpha(x - \varepsilon)]\} \tag{15}$$

with parameters $\alpha = \beta_h$ and $\varepsilon = \ln(\lambda t_0) / \beta_h$. Assuming different distributions for random variable H , various approximated forms of annual maxima cdf can be obtained. For example, if H is distributed as a generalized Pareto law or as a mixture of two exponentials, the approximated forms are respectively GEV distribution (Wang, 1991) and TCEV distribution (Rossi et al., 1984). These results indicate that PWN model is very close to classic AM distribution for small amplitudes of interval Δt while diverges from these ones when Δt increases. For example figure 6 shows the typical behaviour of AM distributions derived for PWN model by expression (11) and its approximation (15), for various interval amplitude Δt and fixed values of parameters ($\lambda = 0.01 \text{ h}^{-1}$, $\beta_h = 0.1 \text{ mm}^{-1}$).

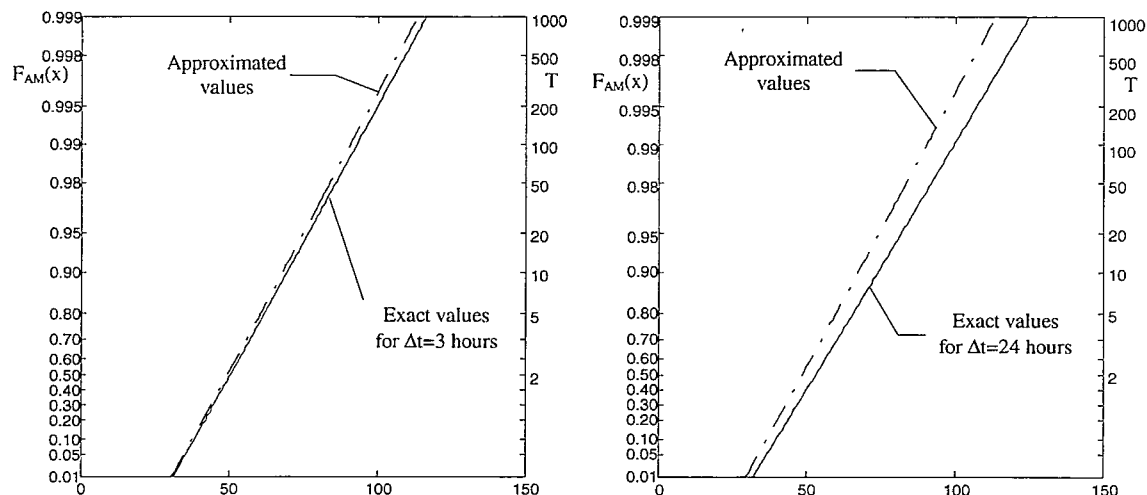

Figure 6 : Comparison between approximated and exact AM distributions for PWN model.
Figure 6 : Comparaison entre les distributions approximées et exactes des maximums annuels du modèle PWN

As regards to other stochastic models described above, only for the PRP model Bacchi et al. (1987) derived an approximated distribution of the annual maxima, under the hypothesis of independent marks, that corresponds to non overlapping consecutive storms. For the models based on cluster processes, there are no analytical expressions about the distribution of extremes. This lack of knowledge is due to the analytical complexity of the models structure.

Some indications about the capability of cluster models in reproducing the behaviour of extremes can be obtained only by numerical simulation.

These results, obviously, can be retained valid only for the values of parameters employed in the simulations. Generally the increase in the number of parameters brings to a better capability in reproducing the variability of extremes (Velghe et al., 1994).

5 Conclusions

The most diffused stochastic models used in the rainfall analysis have been presented. For these models the main properties of the extreme values have been discussed. Particularly for the simple PWN model it has been shown how the annual maximum distribution is very close to the classic annual maximum distributions used in the analysis of hydrological extremes. This result holds especially for small aggregation intervals Δt . On the contrary for the more complicated models it is not possible to derive theoretically the distribution of extremes, due to the complexity of their analytical structure.

Short conclusion

Brève conclusion

M.C. Llasat

Taking into account the strong role played by the orography in high rainfalls, three of the contributions to this chapter have been devoted to this question. In the first, Desurosne and Leblois show the relationship between orography and rainfall intensities in the French Alps. These analyses have been made from the hourly-data obtained by the TPG network since 1986 (stations from Cemagref, Météo-France and Electricité de France). After a meteorological classification of the events, the synthesis derived from the analysis made on this alpine transect crossing the Bas-Dauphiné (1000 m), the Chartreuse (2000 m) and the Belledonne (2500 m) chains, shows the IdF distribution for each station. The relief effect is not very important for the return period but, on the contrary, it has a great role for the duration. In this case, for short durations (< 12 h), the relationship rainfall-relief is less important (with some exceptions for the internal valleys between the mountains), but for long durations (>1 jour) the quantiles of rainfall change clearly with the altitude. Finally, the authors propose some rough synthesis models combining rainfall, duration and altitude.

In the second, M. Brilly analyses the rainfall distribution in the Soca river watershed (Slovenia and Italy), which is placed in one of the Mediterranean regions with the greatest number of thunderstorms. More than six major floods were recorded, during the years 1992 and 1993 alone, in this region, characterized by a very complicated orography. The analysis has been made using daily data from 45 rainfall stations, for a region of 5695 km², and selecting four heavy rainfall events that occurred between 1992 and 1993, all of them with cumulated precipitations near or above 200 mm. The conclusions showed that in the mountainous areas the orographic effect leads the major rainfall to the highest altitudes (in this case, under 2000 m); the daily rainfall data for watersheds correlate much better than the point rain gauge data; and the linear regression between different sub-watershed samples is better for high rainfall.

The contribution made by Z. Radic shows the applications of weather radar in hydrology and, specifically, in mountain basins. Taking into account that in 1980 a network of 13 weather radars was established in Yugoslavia, he illustrates the new possibilities for regional analysis of rainfall spatial distribution and of storm dynamics, and he draws attention to the need of introducing hydrological runoff models which take into account the effect of storm movement. A relationship between weather radar and GIS is also presented. The examples showed made reference to the river Kolubara and to the river Drina basins.

Statistical characterization of maximum rainfalls is made by J.Ferrer, on the basis of the annual maximum series. In order to combine local and regional data, he has used the "index variable" schema. In this context, he proposes the adoption of the SQRT-ET_{max} model which allows the regional law to be expressed as a function of a single parameter estimated by MOM and, for the local scale factor, the mean of the AMS. In order to obtain and represent the results, he uses GIS. The technique showed is applied to the case of Spain, using the raster GIS called IDRISI.

The communication of Ferrari and Iiritano presents the most widely distributed stochastic models used for rainfall analysis in Italy, and proposed in FRIEND practices. These models are made either for reproducing the occurrence process or for reproducing the storm model.

Finally, the contribution made by M.C.Llasat is devoted to the meteorological aspects of high rainfalls. After a brief discussion of the concept of "convective" process, she shows the different

kinds of convective systems and the conditions needed for the production of heavy rainfalls. Some results obtained for heavy rainfall events in Catalonia are displayed. The conclusions of this paper not only apply to all the technical aspects of this chapter. They also constitute a call for meditation about the forecasting and prevention of high rainfalls and floods.

These conclusions lead on to a more general conclusion for the whole chapter. Although some people may think that the different aspects covered are not very closely inter-related, the analysis of "extreme rainfall" calls for use of all the techniques and their results shown here. In order to reach a good definition of "extreme rainfall", and good regionalization, one has to adopt a statistical approach. On the other hand, stochastic models play a fundamental role in the prevention of floods. Once the features of one region have been well determined, the analysis of the rainfall behaviour is the next step. Tools such as weather radar or satellite imagery are needed increasingly day after day to do this analysis. On the other hand, to improve the calibration of these tools, a good meteorological knowledge of the different kind of events is needed too. And taking into account the complex orography of a great part of the regions affected by high rainfalls, the role of this element must be analysed. Finally, GIS has proved to be most useful in representing the different results and in allowing efficient overlapping, for control and comparison.

ooooo

Compte tenu du rôle important joué par l'orographie dans les fortes pluies, trois des contributions de ce chapitre ont été consacrées à ce problème. Dans la première, I. Desurosne et E. Leblois ont montré la relation existant entre l'orographie et la pluie dans les Alpes françaises. Ces analyses ont été réalisées à partir de données horaires obtenues via le réseau TPG du Cemagref depuis 1986, et quelques stations de Météo-France et Electricité de France. Après une classification météorologique des événements, les analyses synthétiques conduites sur la base du transept alpin allant du Bas-Dauphiné (1000 m.) à la Chartreuse (2000 m.) montrent la distribution des IdF pour chaque station. L'effet du relief sur la période de retour n'est pas très important, mais, à l'opposé, il a un fort rôle sur la durée. Dans ce cas, pour des courtes durées (< 12 h) la relation pluie-relief n'est pas très importante (à l'exception des vallées intérieures entre les montagnes), mais pour des longues durées (> 1 j), les quantiles de pluie évoluent, généralement en parallèle selon l'axe des pluies. Finalement, les auteurs proposent des modèles sommaires de synthèse mettant en relation la pluie, la durée et l'altitude.

Dans la seconde contribution, M. Brilly analyse la distribution des pluies dans le bassin du fleuve Soca (Slovénie et Italie), qui est situé dans une des régions de la Méditerranée la plus soumise aux orages. Plus de six crues majeures ont été enregistrées au cours des seules années 1992 et 1993, dans cette région caractérisée par une orographie très complexe. Les analyses ont été réalisées à l'aide de données journalières de 45 stations pluviométriques, sur une région de 5695 km², et en sélectionnant 4 événements de forte pluie entre 1992 et 1993, ayant tous des précipitations cumulées de plus ou moins 200 mm. Les conclusions montrent que dans les zones montagneuses, l'effet orographique amène la majorité des pluies aux plus hautes altitudes (toutefois ici inférieures à 2000 m). Les données de pluie journalières pour l'ensemble du bassin (moyennes spatiales) donnent une meilleure corrélation que les données de pluviométrie locale ; et la régression entre différents sous-bassins est meilleure pour les fortes (hautes) pluies.

La contribution proposée par Z. Radic montre des applications des radars météorologiques en hydrologie, et spécifiquement dans les bassins montagneux. En prenant en compte le fait qu'en 1980, un réseau de 13 radars météorologiques a été installé en Yougoslavie, il montre les nouvelles possibilités pour l'analyse régionale de la distribution spatiale des pluies et de la dynamique des orages, et attire l'attention sur la nécessité d'introduire des modèles d'écoulement hydrologiques prenant en compte ces effets des mouvements (advections) orageux. Une relation entre radar météorologique et SIG est également présentée. Les exemples proposés font référence aux bassins des rivières Kolubara et Drina.

J. Ferrer présente la caractérisation statistique des pluies maximales, sur la base de séries de maximums annuels. Afin de combiner les données locales et régionales, il a utilisé un schéma d'"index variable". Dans cette idée, il propose d'adopter le modèle $SQRT-ET_{max}$, qui permet d'exprimer la loi régionale en fonction d'un seul paramètre estimé par MOM et, pour le facteur d'échelle locale, la moyenne de l'AMS. Afin d'obtenir puis de bien représenter les résultats, il utilise un SIG. La technique ainsi proposée est appliquée au cas de l'Espagne en utilisant le SIG raster IDRISI.

La contribution de E. Ferrari et G. Iiritano présente les modèles stochastiques les plus diffusés en Italie pour l'analyse des pluies, et qui ont été proposés dans FRIEND. Ces modèles sont destinés, soit à reproduire les processus d'occurrence, soit à reproduire les modèles d'orage.

Enfin, la contribution proposée par C. Llasat est consacrée aux aspects météorologiques des fortes pluies. Après une brève discussion sur le concept de processus « convectif », elle montre les différents types de systèmes convectifs, et les conditions requises pour la production de fortes pluies. Quelques résultats obtenus pour des événements de fortes pluies en Catalogne sont présentés. Les conclusions de cette contribution ne se réfèrent pas seulement à tous les aspects techniques développés dans ce chapitre, mais prétendent être un appel à une réflexion sur la prévision et la prévention des pluies fortes et des crues.

Cette conclusion peut amener à la conclusion plus générale de l'ensemble de ce chapitre. Bien que certaines personnes puissent penser que les différents aspects évoqués ici ne sont pas très liés entre eux, l'analyse des « pluies extrêmes » nécessite l'utilisation de toutes les techniques décrites ici, et de leur résultats. Afin d'avoir une bonne définition des « pluies extrêmes » et une bonne régionalisation, il est nécessaire de travailler à partir d'un point de vue statistique. D'une part, les modèles stochastiques jouent un rôle fondamental dans la prévention des crues. Une fois que les caractéristiques d'une région sont bien déterminées, l'analyse du comportement des pluies constitue l'étape suivante. Les outils tels que les radars météorologiques, ou l'imagerie satellite sont, jour après jour, plus nécessaires pour réaliser de telles analyses. D'autre part, pour améliorer le calage de ces outils, une bonne connaissance météorologique des différents types d'événements est également requise. Il faut aussi prendre en compte l'orographie complexe d'une grande part des régions affectées par les pluies fortes, et analyser son rôle. Finalement, l'usage de SIG s'est révélé des plus utiles pour représenter les différents résultats et les discuter en les superposant.

References of chapter 5

Références bibliographiques du chapitre 5

- Acreman M.C. and Sinclair C.D., (1986) : Classification of drainage basins according to their physical characteristics; An application for flood frequency analysis in Scotland. *J. Hydrol.*, 84, 365-380.
- Arnell N. y Gabriele S., (1988) : The Performance of the Two-Component Extreme Value Distribution in Regional Flood Frequency Analysis. *Water Resour. Res.*, 24(6) , 879-887.
- Bacchi B., La Barbera P. and Rosso R., (1987) : *Storm characterization by poisson models of temporal rainfall*. Proc. XXII IAHR Congress, Losanna, vol. "Urban drainage hydraulics and hydrology", 35-40.
- Bacchi B., Becciu G. and Kottegoda N.T., (1994) : *Bivariate exponential model applied to intensities and duration of extreme rainfall*. *J. Hydrol.* 155, 225-236.
- Benson M.A., (1968) : Uniform flood frequency estimating methods for federal agencies. *Water Resour. Res.*, 4(5), 891-908.
- Bergeron T., (1965) : On the low-level redistribution of atmospheric water caused by orography. In : Suppl. Proc. Int. Phys., Tokyo, pp 96-100.
- Blanchet G., (1990) : Régimes météorologiques et diversité climatique dans l'espace Rhônalpin. In : *Revue de Géographie de Lyon*, Vol. 2.
- Blanchet G., (1996) : Communication personnelle.
- Bois P., Obled C., De Saintignon M.F., Mailloux H., (1995) : Atlas expérimental des risques de pluies intenses (Cévennes Vivarais) - 22 planches A3 + une notice
- Bolton, D., (1980) : 'The computation of equivalent potential temperature', *Mon. Wea. Rev.*, **108** 1980: 1046-1053.
- Borga, M., Fattorelli, S. and Giaretta, P. (1991) : *Radar data processing methodology and distributed hydrological modelling for flood forecasting*, Proc. Int. Conf. on Computer applications in water resources, Vol. 1, Taiwan, R.O.C.
- Bras L.R. (1988) : *New approaches to real-time flood forecasting: Wether radar and fluvial geomorfology in hydrology*, International Workchop on Natural Disasters in European-Mediterranean Countries, Perugia, Italy
- Brilly M, Rakovec J., Vidmar A., Garantini M., Cegnar T., Divjak M., Gorišek M., Mikoš M. (1995) : *Wether radar and storm and flood hazards* - Slovenian contribution. Unpublished report CEC - PECO project CIPDCT925090
- Brooks, H.E., Doswell III C.A., and Maddox R.A., (1992) : On the use of mesocale and cloud-scale models in operational forecasting. *Wea. Forecasting*, 7, 120-132.
- Chappell, C.F., (1986) : Quasy-stationary convective events. *Mesoscale Meteorology and Forecasting*, Amer. Meteor. Soc., 289-310.
- Charba, J.P., and Y. Sasaki, (1971) : Structure and movement of the severe thunderstorms of 3 April 1964 as revealed from radar and surface mesonetwork data analysis. *J. Meteor. Soc. Japan*, 49, 191-213.
- Chisholm A.J. and Renick, J.H., (1972) : "The Kinematics of multicell and supercell Alberta hailstorms". *Alberta Hail Studies*. Research Council of Alberta Hail Studies, Report 72-2, pp 24-31.
- Cowpertwait P.S.P., O'Connell P.E., Metcalfe A.V. and Mawdsley J.A., (1996) : *Stochastic point process modelling of rainfall. I. Single site fitting and validation*. *J. Hydrol.* 175, 17-46.
- Cox D.R. and Isham V., (1980) : *Point processes*. Chapman and Hall, London.
- Cunnane C., (1987) : *Review of statistical models for flood frequency estimation*. Regional Flood Frequency Analysis, 49-95, Ed. V.P.Singh. Reidel Publishing Company.
- Daley D.J. and Vere-Jones D. (1988) : *An Introduction to the theory of point processes*. Springer -Verlag, New York.
- Dalrymple, T., (1960) : *Flood frequency analyses*. Water Supply Pap. 1543-A, U.S. Geological Survey, Reston, Va.
- Desurosne I., (1993) : Gradients d'intensités de pluie en zones à relief : expérimentations et premières modélisations des données d'un réseau rhônalpin, le TPG. Rapport final de Xème plan. Contrat Etat-Région Rhône-Alpes, Risques Naturels en Montagne et Inondations en Vallées, Programme n°2, *Intensités de Pluies et Reliefs*, Cemagref, janvier 1993. 47 p.
- Desurosne I., Ribot-Brunot J., Watremez S., Oberlin G., (1996) : Interactions Pluies/Reliefs à l'échelle des intensités. Guide pratique des données pluviographiques et des résultats d 'un réseau pré-alpin, le TPG (période 1987-1995). Publication Cemagref.

- Doswell, C.A.III (1985) : *The Operational Meteorology of Convective Weather*. Vol. II: Storm Scale Analysis. NOAA Tech. Memo. ERL ESG-15, Available from the author at National Severe Storms Laboratory, 1313 Halley Circle, Norman, OK 73069, 240 pp.
- Doswell, C.A. and Burgess D.W. (1993) : Tornadoes and tornadic storms: A review of conceptual models. *The Tornado: Its Structure, Dynamics, Prediction, and Hazards* (Geophys. Monogr. 79), Amer. Geophys. Union, 161-172.
- Doswell, Ch.A. III (1993) : Flash flood-producing convective storms: current understanding and research. *Report of the Proceedings of the U.S.-Spain Workshop on Natural Hazards*. Barcelona, 8-11 June 1993.
- Dutton, E.J. and Dougherty H.R. (1979) : "Year-to-Year Variability of Rainfall for Microwave Applications in the USA". *IEEE. Trans. on Comm.* **COM-27**, 5, pp. 829-832.
- Eagleson P.S., (1972) : *Dynamic hydrology*. McGraw-Hill.
- Eagleson P.S., (1978) : *Climate soil and vegetation: 2. The distribution of annual precipitation derived from observed storm sequences*. *Water Resour. Res.*, 14 (5), 713-721.
- Eastman, J.R., (1992a) : *IDRISI user's guide*. Idrisi project.
- Eastman, J.R., (1992b) : *IDRISI technical reference manual*. Idrisi project.
- Entekhabi D., Rodriguez-Iturbe I. and Eagleson P.S., (1989) : *Probabilistic representation of the temporal rainfall process by a modified Neyman-Scott Rectangular Pulse model: parameter estimation and validation*. *Water Resour. Res.*, 25 (2) 295-302.
- EPA (1988) : *GEO-EAS Geostatistical Environmental Assessment Software*. User's Guide US, Environmental Protection Agency.
- Etoh T., Murota A. and Nakanishi M., (1987) : SQRT-Exponential type distribution of maximum. *Regional Flood Frequency Analysis*, Ed. V.P.Singh. Reidel Publishing Company 253-265.
- Ferrari E., Gabriele S., Rossi F., Versace P. and Villani P., (1990) : *La valutazione delle piene in Calabria. Aspetti metodologici di una analisi a scala regionale*. XXII Convegno di Idraulica e Costruzioni Idrauliche. Cosenza 4-7 Ottobre 1990.
- Ferrer F.J. and Ardiles L., (1994) : Frequency Analysis of Daily Rainfall Annual Maximum Series in Spain. International Conference Developments in Hydrology of Mountainous Areas, Stara Lesna, Slovakia, September 1994.
- Ferrer F.J., (1996) : *El modelo de función de distribución SQRT-ET_{max} en el análisis regional de máximos hidrológicos: aplicación a lluvias diarias*. Tesis Doctoral, Univ. Pol. Madrid.
- Florentino M., Gabriele S., Rossi F., and Versace P., (1987) : Hierarchical approach for regional flood frequency analysis. *Regional Flood Frequency Analysis*, Ed. V.P.Singh. Reidel Publishing Company, 35-49.
- Flahaut B., Andrieu H. and Gilbert C. (1991) : Logiciel d'Hydrologie Radar HYDRORAD, Seminaire international annuel du Groupe AMHY de FRIEND, Lyon, France
- FRIEND, (1989) : *Flow Regimes from Experimental and Network Data*, Vol. I, Hydrological Studies. Ed. Institute of Hydrology, Wallingford. 344 pp.
- Galéa G., Michel C., Oberlin G., (1983) : Maximal rainfall on a surface - the epicentre coefficient of a 1- to 24-hour rainfall, *Journal of Hydrology*, volume 66, pages 159-167
- Holton, J.R., (1971) : *An Introduction to Dynamic Meteorology*, 2nd edn, Academic Press, London, pp. 391.
- Hosking J.R.M., Wallis J.R. and Wood E.F, (1985) : An appraisal of the regional flood frequency procedure in the UK *Flood Studies Report*. *Hydrol. Sci. J.*, 30, 85-109.
- Hoskins, B.J. and Pedder, M.A., (1980) : The diagnosis of middle latitude synoptic development. *Quar. J.R. Meteor. Soc.*, 106: 707-719.
- Houze, R.A., S.A. Rutledge, M.I. Biggerstaff, and B.F. Smull, (1989) : Interpretation of Doppler weather radar displays of midlatitude mesoscale convective systems. *Bull. Amer. Meteor. Soc.*, 70, 608-619.
- Humbert J., Perrin J.-L., (1993) : Precipitation et relief ; le cas du versant oriental des Hautes Vosges, in "L'eau, la terre et les hommes", ouvrage en hommage à R. Frécaut, Presses universitaires de Nancy, septembre 1993, pages 147-154
- Jansà, A. (1990) : *Notas sobre análisis meteorológico mesoscalar a niveles atmosféricos bajos*. Instituto Nacional de Meteorología. Madrid, Spain.
- Jovanovic, S. and Radic, Z.M. (1981) : *ILR model*, Tech. Report, Fac. Civil Eng., Univ. Belgrade (in Serbian).
- Jovanovic, S., Jovanovic, M. and Radic, Z.M. (1983) : The effects of meteorological input on the variability of runoff with time. *Proc. of the Hamburg Symp., IAHS Publ. no. 140*, pp. 375-385.
- Kavvas M.L. and Delleur J.W., (1981) : A stochastic cluster model of daily rainfall sequences. *Water Resour. Res.*, 17 (4), 1151-1160.

- Khaliq M.N. and Cunnane C., (1996) : Modelling point rainfall occurrence with the Modified Bartlett-Lewis Rectangular Pulses model. *J. Hydrol.* 180, 109-138.
- Kieffer A., (1995) : Etude des pluies de fréquence rare a faibles pas de temps sur les Alpes Françaises - relation avec le relief - Mémoire de DEA MMGE, Université Joseph Fourier, Grenoble ; 54 pages et annexes
- Lang M., (1995) : Comparaison des modes d'échantillonnages par sélection du maximum annuel et des valeurs supérieures à un seuil. Conférence internationale en l'honneur de J. Bernier, UNESCO, Paris, 11-13 septembre 1995.
- Langbein W.B., (1949) : Annual floods and the partial duration flood series. *Trans. Am. Geophys. Union*, 30, 879-881.
- Leblois E., Desurosne I., (1994) : Regionalization of rain intensities in the french alpine area : a methodological test for interpolation in mountainous areas. Actes de la Conférence FRIEND-AMHY, Stara-Lesna, High Tatras, Slovaquie, 10-16 sept. 1994. 11p.
- Leblois, (1996) : Contribution au thème CV11b (Pluies rares) dans la prédétermination des risques de crues, des pluies et des crues rares extrêmes / modèles d'estimation des débits adaptés aux petits bassins, in Rapport final de la convention n° M07314 Cemagref-région Rhône-Alpes dans le cadre du Xème Contrat de Plan Etat-Région.
- Llasat, M.C. and Puigcerver M. (1985) : Un intento de aplicación a la Península Iberica de un modelo empírico de precipitación. *Revista de Geofísica*, 41, 135-144.
- Llasat, M.C. and Rodriguez R. (1992) : "Extreme Rainfall Events in Catalonia. The Case of 12 November 1988". *Natural Hazards*, 5, 133-151
- Llasat, M.C. and Barrantes J. (1996) : Catastrophic Rainfalls in the West Mediterranean Area. *Meccanica* 31, 397-406
- Llasat, M.C. , Ramis C. and Barrantes J. (1996) : The Meteorology of High-Intensity Rainfall Events Over the West Mediterranean Region. *Remote Sensing Reviews*, 14, 51-90
- Maddox R.A., (1980) : Mesoscale convective complexes. *Bull. Amer. Meteor. Soc.*, 61, 1374-1387.
- Maddox R.A. (1985) : The relation of diurnal, low-level wind variations to summertime severe thunderstorms. Preprints, *14th Conf. Severe Local Storms* (Indianapolis, IN), Amer. Meteor. Soc., 202-207.
- Margoum M., Oberlin G., Lang M., Weingartner R., (1994) - Estimation des crues rares et extrêmes : principes du modèle AGREGEE. *Hydrologie Continentale*, Vol. 9, n° 1, 1994, pp 85-100.
- Marien J.L. and Vandewiele G.L., (1986) : A point rainfall generator with internal storm structure. *Water Resour. Res.*, 22 (4), 475-482.
- NERC, (1975) : Flood Studies Report. Nat. Environ. Res. Council, London, Vols. 1 - 5, 1100 pp.
- Obeysekera J.T.B., Tabios III G.Q. and Salas J.D., (1987) : On parameter estimation of temporal rainfall models. *Water Resour. Res.*, 23 (10), 1837-1850.
- Onof C. and Wheeler H.S., (1994) : Improved fitting of the Bartlett-Lewis Rectangular Pulse model for hourly rainfall. *Hydr. Sc. J.* 39 (6), 663-680.
- Parzen E., (1962) : *Stochastic Processes*. Holden-Day, San Francisco.
- Petrovic, J. and Radic, Z.M. (1994) : Effects of topography on rainfall spatial structure in the Drina basin, *Vodoprivreda*, 147-149, pp. 45-53 (in Serbian).
- Petrovic, J. and Elgy, J. (1994) : The use of Meteosat infrared imagery for enhancement of areal rainfall estimates, *Proc. Int. Conf. Remote Sensing and GIS in Urban Waters* (UDT '94), Moscow-Volga, pp. 29-40.
- Philips D.L., Dolph J. and Marks D., (1992) : A comparison of geostatistical procedures for spatial analysis of precipitation in mountainous terrain. *Agric. and Forest Meteorol.*, 58, 119-141.
- Radic, Z.M. (1978) : *Laboratory experimental hydrological system*, Tech. Report, Fac. Civil Eng., Univ. Belgrade (in Serbian).
- Radic, Z.M. (1982) : General ILR model for design of large storm sewers, in *Urban Drainage Systems*, ed. R.E. Feathersbone and A. James, Pitman Advanced Publ., pp. 2-179 - 2-187.
- Radic, Z.M. (1989) : *Modelling of runoff from uniform and non-uniform storms based on data from laboratory catchments*, Ph.D. thesis, Fac. Civil Eng., Univ. Belgrade (in Serbian).
- Radic, Z.M. and Jovanovic, S. (1987) : An adaptive distributed model for real-time flood hydrograph forecasting, *Proc. XIII Conf. of Danube countries on hydrological forecasting*, Belgrade.
- Radic, Z.M., Milinkovic, M. and Sakota, V. (1989) : Analysis of the meteorological radar data, *Proc. Yug. Conf. on Flash Floods*, Yug. Assoc. for Hydrology, Belgrade (in Serbian).
- Radic, Z.M. and Petrovic, J. (1989) : Modelling of runoff from moving storms, *Proc. Yug. Conf. on Flash Floods*, Yug. Assoc. for Hydrology, Belgrade (in Serbian).

- Radic, Z.M. (1994) : Analyse par radar de la variation des intensités dans les événements pluvieux, *UNESCO Documents techniques en hydrologie, SC-94/W.S.2D*, Paris, pp. 190.
- Ramis, C., Alonso S. and Llasat M.C., (1995) : 'A comparative study between two cases of extreme rainfall events in Catalonia'. *Surveys in Geophys.*, **16**, 141-161
- Reed D.W., (1992) : Rainfall frequency analysis for flood design. Preproceedings of the NATO ASI on "Copyng with Floods", E. Majorana Centre, Erice, Novembre 3-15, 17 pp.
- Rice, P.L. and N.R. Holmberg, (1973) : 'Comulative Time Statistics of Surface-Point Rainfall Rates', *IEEE Trans. on Comm.* COM-21, **10**, 1131-1136.
- Rodda J. (1967) : The rainfall measurement problem. IAHS Publ 78, 113-120.
- Rodriguez-Iturbe I., Gupta V.K. and Waymire E., (1984) : Scale consideration in modeling of temporal rainfall. *Water Resour. Res.*, **20** (11) 1611-1619.
- Rodriguez-Iturbe I., Cox D.R. and Isham V., (1987a) : Some models for rainfall based on stochastic point processes., *Proc. R. Soc. Lond., Ser. A*, **410**, 269-288.
- Rodriguez-Iturbe I., Febres de Power B. and Valdes J.B., (1987b) : Rectangular pulses process models for rainfall: analysis of empirical data. *J. Geophys. Res.*, **92** (D8), 9645-9656.
- Rossi F., Fiorentino M and Versace P., (1984) : Two component extreme value distribution for flood frequency analysis. *Water Resour. Res.*, **20**(7), 847-856.
- Rossi F., Fiorentino M. and Versace P., (1984) : Two component extreme value distribution for flood frequency analysis. *Water Resour. Res.*, **20**(7), 847-856.
- Sevrub B., L. Zahlavova , (1994) : The Effect of Systematic Error of precipitation Measurement on Vertical gradients of Precipitation in Switzerland. 23 international Tagung fur Alpine Metereologie, *Annalen der Meteorologie* **30**, Offenbach am Main.
- Sirangelo B., (1992) : *Intensity-duration-frequency curves from rainfall stochastic models with beta shaped pulses*. Proceedings of sixth IAHR internation symposium on stochastic hydraulics. May 18-20, Taipei, Taiwan.
- Sirangelo B., (1994) : Un modello poissoniano non omogeneo per l'analisi delle precipitazioni cumulate su lunghi intervalli temporali. *Idrotecnica.* **3**, 125-158.
- Sirangelo B. and Versace P., (1990) : Stima dei parametri ed intervalli di aggregazione nei modelli puntuali di precipitazione. Atti del 22° Convegno di Idraulica and Costruzioni Idrauliche, Cosenza, Vol. 3, 373-405.
- Témez J.R., (1991) : Extended and Improved Rational Method. Version of the Highways Administration of Spain" Proc. XXIV IAHR Congress. Madrid (Spain). Vol A., 33-40.
- Todorovic P. and Yevjevich V., (1969) : *Stochastic process of precipitation*. Hydrologic papers of the Colorado State University. Paper 35, Fort Collins, Colorado.
- Todorovic P., (1978) : Stochastic models of floods. *Water Resour. Res.* **14** (2), 345-356.
- USWRC, (1981) : *Guidelines for determining flood flow frequency*. Bulletin 17B, Hydrology Committee, Water Resources Council, Washington.
- Velghe T., Troch P. A., De Troch F. P. and Van de Velde J., (1994) : *Evaluation of cluster based rectangular pulses point processes*. *Water Resour. Res.*, **30**(10), 2847-2857.
- Wang Q.J., (1991) : *The POT model described by the generalized Pareto distribution with Poisson arrival rate*. *J. Hydrol.* **129**, 263-280.
- Watremez S., (1996) : Analyse fine de l'évolution spatio-temporelle des intensités de précipitation dans les pré-Alpes du Nord ; actualisation des premiers résultats au vu des nouvelles données 1992-1995. Maitrise de Gestion et de Restauration des Eaux Douces, Université Blaise Pascal, Clermont-Ferrand, sept. 1996. 2 tomes.
- Weisman , M.L. and J.B. Klemp, (1986) : ' Characteristics of isolated convective storms", In:Ray, P.S.(ed) *Mesoscale Meteorology and Forecasting*, Amer. Meteor. Soc., 331-358
- Wiltshire S., (1986) : Identification of homogeneous regions for flood frequency analysis. *J. Hydrol.*, **84**, 287-302.
- Wiltshire S. and Beran M., (1987a) : Multivariate Techniques for the Identification of Homogeneous Flood Frequency Regions. Regional Flood Frequency Analysis, Ed. V.P.Singh. Reidel Publising Company, 133-145.
- Wiltshire S. and Beran M., (1987b) : A significance test for homogeneity of flood frequency regions". *Regional Flood Frequency Analysis*, Ed. V.P.Singh. Reidel Publising Company, 147-158.
- WMO (1995) : *Infhydro Manual*, World Meteorological Organization, Geneve.

Chapter 6

Physical processes of runoff formation

Short introduction

P. Seuna, A. Lepistö

Runoff formation is a key ecohydrological process and its adequate knowledge and representation are of primary importance for reliable mathematical and hydrodynamic catchment modelling, geochemical budgeting and regionalising process-oriented hydrological information. Instrumented research catchments provide an important basis for developing a better understanding of processes.

One of the keys in any attempt to understand variability in catchment outputs is runoff formation processes. Chemical flux and cycling are intimately linked to the hydrological cycle. Small catchments provide a natural framework for various types of research, e.g. studies concerning nutrient leaching and cycling, mass balances, effects of land use change and hydrological processes. There is increasing emphasis on the aspects of local and global environmental change. The complex interactions between hydrology, chemistry and ecology have ensured that process studies remain a vital element of catchment studies, with catchment outputs providing an integration of within-site processes.

Within the FRIEND project 5, the first objective was to develop a greater understanding of the physical processes and mechanisms responsible for runoff formation, and of variation in flow components in different physiographic and climatic conditions. Local geomorphological, geological and climatic conditions may have a major impact on direct runoff formation. The second objective of the project was to investigate the links between hydrological processes and nutrient leaching.

The main aim of environmental isotope investigations is to learn more about runoff formation. In this chapter, firstly, isotope hydrological investigations are reviewed in a global scale including 90 research catchments, in order to obtain an estimate of variability of direct runoff components and mean residence times in different climatic and physiographic conditions. Information about major features of geology, soils and land use in the research catchments is also included.

Secondly, hydrological processes in forested environments are discussed, including variability of the direct runoff fraction and affecting factors, as obtained from isotope studies in catchments in Central European and Nordic conditions. Particular attention is paid to runoff formation in mountainous environments in the Czech Republic and Slovakia, and recent investigations of the links between hydrological processes and nutrient leaching are reviewed.

Thirdly, processes in agricultural catchments are discussed, including quantification of runoff components and their residence times in an experimental catchment in the Netherlands, hydrogeological balances and results from the SWAP93 model, and processes affecting spatial distribution of drainage in a lysimeter.

Fourthly, recent work of the ERREAU programme dealing with rainfall-runoff modelling and regionalization in larger watersheds is discussed.

Brève introduction

P. Seuna, A. Lepistö

La formation des écoulements est un processus clé de l'écohydrologie, et les connaissances et représentations correspondantes devraient être d'un intérêt fondamental, par exemple pour une modélisation hydrodynamique mathématiquement robuste, ou pour des bilans géochimiques crédibles, ou pour la régionalisation de données hydrologiques servant la connaissance de ces processus. Les bassins de recherche instrumentés fournissent une base importante pour la construction d'une meilleure compréhension de ces processus.

Une des clés de toute tentative de compréhension de la variabilité de la production des bassins se trouve donc dans les processus de formation des écoulements. Dans les régions humides, les flux chimiques et leurs cycles sont intimement liés au cycle hydrologique. Les petits bassins fournissent un cadre naturel pour des recherches variées, telles que les études concernant le lessivage et le recyclage des nutriments, les bilans de masses, les effets du changement de l'occupation des sols, et tous les processus hydrologiques liés. Or il y a un intérêt croissant pour les aspects des changements de l'environnement, tant locaux que globaux. Les interactions complexes entre l'hydrologie, la chimie et l'écologie ont montré que les études de processus restent un élément essentiel de la connaissance des bassins, lesquels ont une production qui intègre les effets de leurs processus locaux.

Dans le cadre du projet n°5 de FRIEND-NEF, le premier objectif était d'arriver à une plus grande compréhension et à une synthèse des processus physiques et des mécanismes responsables de la formation des écoulements, et de la variation de leurs composantes dans différentes conditions physiographiques et climatiques. Les conditions de la géomorphologie locale, de la géologie, et du climat peuvent avoir un effet majeur sur la formation des écoulements directs. Le second objectif du projet était de rechercher les liens entre les processus hydrologiques et le lessivage des substances nutritives.

Les observations faites sur les isotopes naturels visent surtout à acquérir une meilleure connaissance de la formation des écoulements. Dans une première partie de ce chapitre, on a d'abord analysé les recherches d'isotopes hydrologiques menées à une échelle globale sur presque 90 bassins de recherche, afin d'obtenir un panorama de la variabilité des composants des écoulements directs et des temps de séjour moyens, dans différentes conditions climatiques et physiographiques. Les informations sur les principales caractéristiques de la géologie, des sols, et de l'occupation des sols dans les bassins de recherche sont incluses.

Dans une seconde partie, la discussion porte sur les processus hydrologiques en environnement forestier, y compris la variabilité de la fraction directe des écoulements, et les facteurs correspondants, tels qu'obtenus à partir d'études isotopiques menées dans des bassins d'Europe Centrale et des régions nordiques. Une attention particulière est portée sur la formation des écoulements dans les régions montagneuses de la République Tchèque et de la Slovaquie, et de récentes recherches sur les liens entre les processus hydrologiques et le lessivage des substances nutritives sont réexaminées.

Dans une troisième partie, la discussion porte sur les processus en bassins agricoles. Elle concerne la quantification des composants de l'écoulement et leur temps de transit, dans un bassin expérimental aux Pays Bas, des bilans hydropédologiques, des résultats du modèle SWAP93, et les processus affectant la distribution spatiale du drainage dans un lysimètre.

Dans une quatrième partie, le chapitre aborde le problème de la connaissance des processus et de la modélisation pluies-écoulements, dans des bassins peu instrumentés, et à données rares, avec l'exemple de la Côte d'Ivoire.

Global review of isotope hydrological investigations

Revue globale des recherches hydrologiques à l'aide d'isotopes

A. Herrmann

1 Introduction

Environmental isotopes are continually being injected into the land surface via precipitation. This facilitates tracing of the ground phase of the water cycle, which can be structured by connecting major hydrological storages with corresponding water fluxes. Accordingly, information taken from areal-injected isotopes relates to whole catchments, unlike intentionally introduced artificial tracers which trace selected trajectories in the system. The radionuclide tritium ^3H , which mainly originates from nuclear atmospheric bomb tests ('bomb tritium') carried out before the moratorium in 1963 and is still being released from the stratospheric reservoir, as well as the stable isotopes deuterium ^2H and oxygen-18 (^{18}O), are all constituents of water molecules and can, therefore, be considered as ideal hydrological tracers. The physical background and diverse hydrological applications of environmental isotope tracer techniques have been reviewed most comprehensively by Fritz and Fontes (1980) and Moser and Rauert (1980).

The following outlines focus on applications of the isotope technique to the small catchment scale (1-50 km²). Isotopic hydrograph separations make use of the differences between actual event water (input) and older pre-event water stored in the subsurface system, with mean transit time computations for the delayed pre-event water component as the main objectives. Earlier reviews of this kind were presented by Stichler and Herrmann (1982) and Herrmann (1993), whereas Hooper and Shoemaker (1986), Sklash (1990) or Buttle (1994) confined themselves to hydrograph separations.

These reviews are mainly concerned with applications of the isotopic hydrograph separation technique to obtain information about generation of storm and snowmelt runoff, which represent by far the largest number of published studies and study basins. The completion and update of these compilations is one aim of the present contribution. However, in this context one should not forget the specific isotopic marking of the pre-event water. This enables assessment of long-term turnover of water, which is above all controlled by groundwater recharge and exfiltration processes. Therefore, another scope is to determine how well the mean transit times of this delayed component fit other basin parameters. This leads to a most important task of such synopses, i.e. regionalising the hydrological information as acquired from combined hydrologic, isotopic, hydraulic and geochemical investigations as demonstrated for the first time by Stichler and Herrmann (1982), and refined by Buttle (1994) for peak flow conditions of a considerable number of runoff events collected from selected basins.

Overall, it should be borne in mind that the main hydrological scope of environmental isotope hydrological investigations is to learn more about an ecohydrological key process, runoff formation (Herrmann, 1994). Since each study contributes to a better understanding of this process, researchers in the field are kindly invited to contribute by putting respective material to the author's disposal.

2 Modeling techniques

The isotope tracer technique described below makes use of two simple tools: a mixing formula (eq. 3) for hydrograph separation in which the event water can be considered as a bypass flow (direct flow component) from a system hydrological point of view, and a convolution integral being applied to the isotopic input and output functions of the system (eq. 4) with the $g(t)$ time distribution weighting

function as a focal constituent.

The two-component separation represents the most feasible hydrological application of environmental isotopes according to the equations :

$$c_t = c_d d + c_i i \quad (1)$$

$$\text{with } t = d + i; \quad (2)$$

the direct flow proportion is found from the mixing formula :

$$q = (c_t - c_i)/(c_d - c_i) \quad (3)$$

where c is the isotope content, t is the total runoff, d is the direct (event) and i the indirect (pre-event) component. With $c_d = c_p$, the direct component is defined as having the isotope content of precipitation or meltwater, respectively.

The most important assumptions are : sufficient difference between c_d and c_i ; isotopic signatures of p and i components are constant in space and time, or variations are known ; contributions from other surface or external subsurface storages are negligible. Detailed discussion of the assumptions can be found in Buttle (1994). In this context it should be observed that n independent tracers enable separation of $n+1$ components only, and it seems doubtful whether it is realistic to mix different types of tracers, e.g. isotopes and geochemical indicators, in the same tracer balance equation as has been done in several studies mainly aiming to distinguish soil water as a third component. However, since such considerations do not really affect the main finding of the following synopsis, i.e. considerable pre-event water contributions to flood flow, they are marginal in our context, although of some methodological importance in general.

The isotopic signature of the pre-event component can be used to learn about the age distribution pattern of the subsurface system, and also to derive some additional hydraulic parameters of considerable catchment hydrological significance. The following convolution integral describes the relationships between the tracer input and output concentrations of a system for steady-state conditions :

$$C_{\text{out}}(t) = \int_0^{\infty} C_{\text{in}}(t-t') g(t') \exp(-\lambda t') dt' \quad (4)$$

where C_{in} , C_{out} are the tracer input and output concentrations, t and t' are the time and transit time variables, and λ is the decay constant which is zero for stable isotopes. Basin response, or exit age distribution functions $g(t)$ which can be considered as a flow model, is obtained by solving one (dispersion) or two transport equations (dispersion; diffusion) according to the model used. The hydrological application of the model consists of solving the mathematical inverse problem determining flow parameters in *a priori* $g(t)$ by fitting the theoretical to experimental tracer output concentrations. For varying conditions, Zuber et al. (1986) found $g(t)$ parameter values that did not differ considerably from those under steady-state in the case of Lange Bramke (cf. D-3 in Table 1).

Relevant $g(t)$ functions for environmental isotopes were discussed by Zuber (1986). Apparently, $g(t)$ functions differ in the number and meaning of fitting (flow) parameters. However, all models include t_0 , which is the mean transit time of water as a major hydraulic parameter, except for the Ordinary Dispersive Model (ODM). This is true for the early single parameter Exponential Model (EM) dating from the late 1950s, which is mathematically equivalent to the well-mixing model, and for the Dispersive Model (DM) which was introduced to hydrology at the begin of the 1980s, and has an additional dispersion parameter (D/vx). Since application of the convolution integral does not include any integration over the recharge area, the values of the dispersion constant (D/v) are several orders of

magnitude greater than those found from artificial tracer experiments on macro-dispersion in the field scale. It may be expected that the apparent values of D/v from environmental isotope studies will be approximately equal to the length (x) of recharge zones measured along streamlines.

In the case of dual porosity, i.e. soils with macropores or bedrock with fractures and fissures in a porous matrix, tracer diffusion in the matrix must be accounted for as well as dispersion. In such cases ODM can be applied with two fitting parameters: mean transit time of tracer (t_t) and a purely mathematical parameter (D^*/vx) describing the variance of transit time distributions of the tracer in the system due to dispersion in macropores and fissures, and diffusion to the porous matrix. Hydrologists should, therefore, observe that they determine t_t instead of t_o in this case, with both of these residence times representing different hydrological information.

Other factors making the application of environmental isotopes in combination with $g(t)$ basin response functions attractive, include the following hydraulic basin parameters, all of which are of hydrological importance: volume of mobile water $V_m (=Q t_o$; with Q as flow rate) in the storage under consideration, its effective porosity $n_{eff} (=V_m/V_t$; with V_t as total reservoir volume), and the mean aquifer thickness $H_{aq} (H_w/n_{eff}$; with H_w as V_m water column equivalent).

Finally, it should be realised that in case of double porosity with $t_t > t_o$, only the whole [i.e. mobile (m) plus stagnant (s)] water volume $V = V_m + V_s$ and total porosity $n (=n_p + n_r$; with p representing matrix, and r fractures and macropores) can be assessed. To calculate t_o from t_t the retardation factor (R_p) as a result of tracer diffusion to the matrix is also needed: $t_o = t_t / R_p$. This can be obtained as a first approximation by applying :

$$R_p = t_t/t_o = V/V_m \approx 1 + (n_p/n_r) \quad (5)$$

3 Global review

Distribution patterns

The maps (Figs. 1 and 2) and Table 1 include small catchments with isotope hydrological investigations of single runoff components and mean residence times for pre-event (subsurface) water. These updated listings of experimental work on isotopic hydrograph separation and transit time calculation have been completed together with information about major features of geology, soils and land use where available, in order to meet the requirements for adequate interpretation of specific hydrological behaviour.

The global distribution of 90 isotope hydrological study catchments indicates their concentration in the northern mid-latitudes, i.e. in the North American continent with southeastern Canada and eastern United States as focal areas, in Central Europe including the Alps, and in Scandinavia. In this compilation Germany and USA are represented by 14 and 13 study catchments, followed by Canada (11) and France (9). The distribution pattern suggests that costly isotope studies are associated with higher funding and scientist potentials in the industrialised world. However, in this context one should also consider that towards lower latitudes isotopic input signals may not be usable due to insufficient annual variation (see Fritz and Fontes, 1980 ; Moser and Rauert, 1980).

The earliest component separations were performed with ^3H , whereas at present the stable isotopes ^2H and ^{18}O dominate. The studies are increasingly being complemented by geohydrochemical investigations, indicating higher complexity and multidisciplinary of many recent research projects. The reason for this development is a greater expediency of stable isotope measurements, in combination with the decreasing tritium content of actual precipitation to a low absolute level. This favours the detection of local to regional contamination effects caused by nuclear plants and enterprises and therefore makes more refined analytical techniques necessary.

Table 1 : Synopsis of environmental isotope studies on direct runoff separation and mean residence time calculation (after Stichler & Herrmann 1982 and Herrmann 1993, completed)**Table 1 : Revue des analyses isotopiques pour la séparation des écoulements directs et les temps de séjour moyens.**

Country Code-No.	Continent/Country/Catchment	Surface Area	Topography	Geology/Soils	Land use	Isotope	Direct flow proportion (%)	Mean transit time (yrs.)	Flow model g(t)	Reference
	Europe									
	Austria									
A - 1	Kesselwandbach	C	A	R/r	R/G/B	D,T, (I)	B-C	-	-	Behrens et al. ZGG 7 (1971)
A - 2	Hintereisbach	C	A	R/r	R/G/B	D,T, (I)	C	-	-	Behrens et al. ZGG 7 (1971)
A - 3	Rofenache	D	A	R/r	R/G/P/B	D, T, (I)	B-C	4.0	EM	Behrens et al. ZGG 7 (1971) Behrens et al. IAEA (1979)
A - 4	Vernagtbach	C	A	R/r	R/G/B	D, T, (I)	C	-	-	Behrens et al. ZGG 7 (1971)
A - 5	Pöllau	D	A	R/r	P/F	O	-	1.9	EM	Bergmann et al. SUWT (1986)
	Switzerland									
CH - 1	Dischma	D	A	R/r	P/B	O, I	A(C)	4.0 4.8	EM DM	
CH - 2	Areuse	D	A	K/l	F/A	O, I, (I)	A-C	1-2	EM	Müller et al. SBH 32 (1980)
CH - 3	Alloux	B	H	R/l	P/F	O	B-C	-	-	
CH - 4	Rawil	D	A	K/r	B/G/P/F	T	-	2-4	EM	Schotterer et al. IAEA (1979)
CH - 5	Rietholzbach	B	H	R/l	P/F	O	-	1-2	E(P)M DM	Vitvar UN (1997)
	Czech Republic									
CZ - 1	Modry D_l	B	H/A	R/l	P/F	T	B-C	2.5	BM	Marinec et al. GWA (1972) Dinçer et al. WRR 6 (1970)
CZ - 2	Lysina	A	H	R/s,g	F/P	O, (I)	A	-	-	Busek et al. WASP 79 (1995)
	Germany									
D - 1	Lainbach	C	A	R/r,s,g	F/P	D, O, T D T	A-C (B-C)	2.1 2.2 2.4	EM EM DM	Herrmann et al. Catena (1980) Maloszewski et al. JH 66 (1983)
D - 2	Kreidenbach	B	A/H	R/r,s,g	F	O, (I)	B (C)	1.4	EM	Eden et al. Berne Symp (1982)
D - 3	Lange Bramke	A	H	R/s,g	F	O, T	A-B (A)	2.2 2.4	EM DM	Herrmann et al. LU 17 (1989)
D - 4	Goldersbach	B	H	R/l	F	D	B	-	-	Einsele (ed.) VCH Publ. (1986)
D - 5	Kimbach	C	H	R/l	F	D	B	-	-	Einsele (ed.) VCH Publ. (1986)
D - 6	Wimbach	D	A	R/γ,g	B/F	O, (I) T	A	4.1 4.0 4.0 4.0	EM DM EM DM	Maloszewski et al. JH 140 (1992) " " Maloszewski et al. JH 140 (1992) "
D - 7	Große Schacht	C	H	R/s,g	F	T, O	A	2.5	EM	Sommerhäuser TUBS (1994)
D - 8	Gr. Mollental	B	H	R/s,g	F	T, O, (I)	A	4.0	EM	Sommerhäuser TUBS (1994)
D - 9	Kl. Mollental	B	H	R/s,g	F	T, O	A	1.0	EM	Sommerhäuser TUBS (1994)
D - 10	Alte Riefensbeek	C	H	R/s,g	F	T, O	A	2.5	EM	Sommerhäuser TUBS (1994)
D - 11	Krummbach	A	L	L/l	A	O	A	-	-	Tischer TUBS (1995)
D - 12	Saukappe	A	H	R/sg	F	T	-	3.5	DM	Herrmann et al. LU 17 (1989)
D - 13	Hangental	A	H	R/s,g	F	T	-	2.5	EM	Sommerhäuser TUBS (1994)
D - 14	Wemersbach	B	H	R/l	F	T	-	8-650	EM	Schwarze et al. Proc. Freiberg Isotopenkoll. (1994)
	France									
F - 1	Pont des Blaves	C	A	-	-	T	B	-	-	Crouzet et al. Hydrol. 11 (1970)
F - 2	Charnoisy	C	A	-	-	T	C	-	-	Crouzet et al. Hydrol. 11 (1970)
F - 3	L'Eau Morte	D	A	-	-	T	D	-	-	Crouzet et al. Hydrol. 11 (1970)
F - 4	Le Maravant	B	H	-	-	O, (I)	A-C	-	-	Blavoux MCU (1978)
F - 5	Mélarchez	C	H	-	-	O, (I)	A-C	-	-	Blavoux MCU (1978)
F - 6	Nouvoitou	A	L	R/l	A	O, (I)	B	-	-	Mérot et al. Catena 8 (1981)
F - 7	Cannone	A	H/A	R/r	F	O, (I)	C-D	-	-	Loye-Pilot TNO (1990)

Country Code-No.	Continent/ Country/ Catchment	Surface Area	Topography	Geology/ Soils	Land use	Isotope	Direct flow proportion (%)	Mean transit time (yrs.)	Flow model g(t)	Reference
F - 8.	Rimbaud	B	H	R/r	-	O, (I)	C	-	-	Travi et al. HSI 39 (1994)
F - 9	Les Maurets	C	H	R/r	-	O, (I)	A	-	-	Marc et al. IAHS 229 (1995)
F - 10	Strengbach	A	H	R/l. s	F	O, (I)	A	-	-	Idir et al. UN (1997)
Finland										
FIN - 1	6 Rudbäck	B	L	R/s	F	O	A-B	-	-	Lepistö et al. IAHS 221 (1994)
FIN - 2	7 Rudbäck	C	L	R/s	F/R	O	A	-	-	Lepistö et al. IAHS 221 (1994)
FIN - 3	8 Rudbäck	A	L	R/s	F/R	O	A-C (A)	0.7	EM	« ;Lepistö AF 24 (1994)
FIN - 4	Teeressuonoja	A	L	R/s	F	O, (I)	A-B	-	-	Bengtsson et al. AF 21 (1991)
FIN - 5	Hovi	A	L	s	A	O, (I)	D	-	-	Bengtsson et al. JH 135 (1992)
FIN - 6	Liuhapuro	B	H	s	F/Pe	O	C	-	-	Lepistö IAHS 229 (1995)
Great Britain										
GB - 1	Allt a Mharcaidh	C	H	R/s	Pe	D, (I)	A-C	-	-	Ogunkoya HP 5 (1991)
Italy										
I - 1	Rio delle Fonti	D	A	R/r	R/G/B	O	-	-	-	van de Griend JH 62 (1983)
Norway										
N - 1	Birkenes	B	H	R/s	F/Pe	O	A-B	-	-	Christophersen et al. NHP (1984)
Netherlands										
NL - 1	Hupsele Beek	C	L	L/s	P/A/F	O	A	-	-	Mook et al. IAEA (1974)
Sweden										
S - 1	Nåsten	C	L	R/s.l	F	O	A	-	-	Rodhe NH 12 (1981)
S - 2	Stormyra	B	L	R/s.l	F	O	A	-	-	Rodhe NH 12 (1981)
S - 3	Aspåsen	A	L	R/s.l	F	O	A-C	-	-	Rodhe UUR 41 (1987)
S - 4	Busbäck	A	L	R/s.l	F	O	C	-	-	Rodhe UUR 41 (1987)
S - 5	Gårdsjön	A	L	R/s.l	F	O	A-C	-	-	Rodhe UUR 41 (1987)
S - 6	Svarberget	A	L	R/g.l	F/P	O	A-C	-	-	Rodhe UUR 41 (1987)
Slovak Republ.										
SK - 1	Jalovecky	D	A/H	R/g.l	F/P	D, O	A(A-B)	2.6	DM	Holko JHH 43 (1995)
North America										
Canada										
CND - 1	Wilson Creek	B	L	R/s.l	P	O, (I)	A	-	-	Fritz et al. IAEA (1975)
CND - 2	Kenora	B	L	R/s.l	F	O, (I)	C	-	-	Fritz et al. IAEA (1975)
CND - 3	Big Creek	D	L	L/s.l	P	O, (I)	B	-	-	Fritz et al. IAEA (1975)
CND - 4	Big Otter Creek	D	L	L/s.l	P	O, (I)	C	-	-	Fritz et al. IAEA (1975)
CND - 5	R. Eaux Volées Sub 6	B	H	L/s.l	F	O	A-B	-	-	Sklash et al. JH 43 (1979)
CND - 6	E. Vol. Sub. 7A	B	H	L/s.l	F	O	A-B	-	-	Sklash et al. JH 43 (1979)
CND - 7	Hillman Creek	A	L	L/s.l	A	O, (I)	A	-	-	Sklash et al. JH 43 (1979)
CND - 8	Harp Lake Sub 4	B	H	L/s.l	F	D, O, (I)	A-C	-	-	Bottomley et al. JH 75 (1984)
CND - 9	Harp Lake Sub 5	B	H	L/s.l	F	D, O, (I)	A-C	-	-	Bottomley et al. JH 75 (1984)
CND - 10	Turkey Lakes	C	H	R/s.l	F	D, O, (I)	B	-	-	Bottomley et al. JH 75 (1984)
CND - 11	Duffins Creek	B	H	L/s	F	O, (I)	A-B	-	-	Hill WRR 29 (1993)
USA										
USA - 1	Hubbard Brook	A	H	R/s.l	F	D, (I)	B	-	-	Hooper WRR 22 (1986)
USA - 2	Mattole River	D	H	R/l	F/P	D, O, T(I)	B	-	-	Kennedy et al. JH 84 (1986)
USA - 3	Fish Run	B	H	R/l	F	O	A	-	-	Dewalle et al. JH 104 (1988)
USA - 4	Permanente	C	H	R/l	P/F	D, O	C	-	-	Nolan JH 113 (1990)
USA - 5	Mahantango	C	H	l	A/F	O	A-C	-	-	Pionke et al. JH 148 (1993)
USA - 6	Mahantango Sub	A	H	l	A/F	O	A	-	-	Dewalle JH 163 (1994)
USA - 7	Shaver Hollow	A	H	R/s.l	F	O	A	-	-	Bazemore et al. JH 162 (1994)
USA - 8	Orangeville Rise	D	H	K/l	-	D, O, (I)	A-B	-	-	Lahey WRR 32 (1996)
USA - 9	Clear Creek	C	A	R/r	R/G/B	D	-	-	-	Meiman et al. IAHS 107 (1973)
USA - 10	Little Beaver	D	A	R/r	R/G/B	D	-	-	-	Meiman et al. IAHS 107 (1973)
USA - 11	Imnavait Creek	B	H	L/gelisol	tundra	O	D	-	-	Cooper et al. WRR 27 (1991)

Country Code-No.	Continent/ Country/ Catchment	Surface Area	Topography	Geology/ Soils	Land use	Isotope	Direct flow proportion (%)	Mean transit time (yrs.)	Flow model g(t)	Reference
USA - 12	Upper Sheep Cr.	A	A	R	G	O		-	-	Unnikrishna IAHS 229 (1995)
USA - 13	Falling Creek	D	H	R/r	F	D, O, I (I)	(A)	20-40	D(stat.)	Rose JH 174 (1996)
South America										
Brazil										
BR - 1	Bófalos R.	B	L	s	F/P/A	O	C-D	-	-	Leopoldo et al. IAEA (1987)
BR - 2	Paraiso R.	B	L	s	F/P/A	O	C-D	-	-	Leopoldo et al. IAEA (1987)
French Guayana										
GUY - 1	"A"	A	L	l	P	D, O, (I)	C	-	-	Bariac et al. IAHS 229 (1995)
GUY - 2	"B"	A	L	l	F	D, O, (I)	A-B	-	-	Bariac et al. IAHS 229 (1995)
Asia										
Japan										
J - 1	Inuyama	A	H	R/r	F	O, I, (I)	B	19	DM	Matsubayashi et al. JH 152 (1993)
J - 2	Tonegawa R.	D	H/A	R	-	Sr-89,90	(B-C)	-	-	Yamagata et al. IAEA (1963)
J - 3	Kawakami	A	H/A	R/r	F	T	B	-	-	Matsutani et al. IAHS 215 (1993)
PR China										
PRC - 1	Boerqin	D	A	R/r	B/G/P	O	B	-	-	Gu Weizu IAHS 218 (1993)
Turkey										
TR - 1	Guvenc	C	H	-	-	D, O	A-D (C)	-	-	Günyakti et al. HSI 40 (1995)
Australia & New Zealand										
AUS - 1	Salmon	A	L	g,s	F	D, O, (I)	A-B	-	-	Turner et al. JH 94 (1987)
NZ - 1	Tawhai	B	L	g,s	F	O, (I)	A	-	-	Pearce et al. WRR 22 (1986)
NZ - 2	Glendhu 1	B	H	R/l	P	D	B	-	-	Bonell et al. HP 1 (1990)
NZ - 3	Glendhu 2	B	H	R/l	P	D	C	-	-	McDonnell et al. WRR 26 (1990)

Explanations

Symbols for catchment parameters:

<p>Surface area (km²):</p> <table border="1"> <tr><td>A</td><td>< 1</td></tr> <tr><td>B</td><td>1-5</td></tr> <tr><td>C</td><td>5-20</td></tr> <tr><td>D</td><td>>20</td></tr> </table> <p>Topography:</p> <table border="1"> <tr><td>A</td><td>alpine, high mountain</td></tr> <tr><td>H</td><td>highland</td></tr> <tr><td>L</td><td>lowland</td></tr> </table>	A	< 1	B	1-5	C	5-20	D	>20	A	alpine, high mountain	H	highland	L	lowland	<p>Geology / Soils:</p> <table border="1"> <tr><td>R</td><td>bedrock</td></tr> <tr><td>L</td><td>loose sediment</td></tr> <tr><td>K</td><td>karst</td></tr> <tr><td>r</td><td>regosol</td></tr> <tr><td>g</td><td>gravel</td></tr> <tr><td>s</td><td>sand/silt</td></tr> <tr><td>l</td><td>loam/clay</td></tr> </table>	R	bedrock	L	loose sediment	K	karst	r	regosol	g	gravel	s	sand/silt	l	loam/clay	<p>Land use:</p> <table border="1"> <tr><td>A</td><td>agriculture (cropl.)</td></tr> <tr><td>B</td><td>boulder, (rock)</td></tr> <tr><td>F</td><td>forest</td></tr> <tr><td>G</td><td>glacier, (rock)</td></tr> <tr><td>P</td><td>grassland</td></tr> <tr><td>Pe</td><td>peat</td></tr> </table> <p>Isotopes and other:</p> <table border="1"> <tr><td>D</td><td>Deuterium</td></tr> <tr><td>O</td><td>Oxygen-18</td></tr> <tr><td>T</td><td>Tritium</td></tr> <tr><td>I</td><td>isotope used for transit time calcul.</td></tr> <tr><td>i</td><td>geochem. indicators</td></tr> </table>	A	agriculture (cropl.)	B	boulder, (rock)	F	forest	G	glacier, (rock)	P	grassland	Pe	peat	D	Deuterium	O	Oxygen-18	T	Tritium	I	isotope used for transit time calcul.	i	geochem. indicators	<p>Direct flow proportion (%):</p> <table border="1"> <tr><td>A</td><td>< 20</td></tr> <tr><td>(A)</td><td>seasonal, annual average</td></tr> <tr><td>B</td><td>20-40</td></tr> <tr><td>C</td><td>40-80</td></tr> <tr><td>D</td><td>>80</td></tr> </table> <p>Flowmodels g(t):</p> <table border="1"> <tr><td>BM</td><td>binomial model</td></tr> <tr><td>DM</td><td>dispersive model</td></tr> <tr><td>EM</td><td>exponential model</td></tr> <tr><td>EPM</td><td>exp./piston flow m.</td></tr> </table>	A	< 20	(A)	seasonal, annual average	B	20-40	C	40-80	D	>80	BM	binomial model	DM	dispersive model	EM	exponential model	EPM	exp./piston flow m.
A	< 1																																																																						
B	1-5																																																																						
C	5-20																																																																						
D	>20																																																																						
A	alpine, high mountain																																																																						
H	highland																																																																						
L	lowland																																																																						
R	bedrock																																																																						
L	loose sediment																																																																						
K	karst																																																																						
r	regosol																																																																						
g	gravel																																																																						
s	sand/silt																																																																						
l	loam/clay																																																																						
A	agriculture (cropl.)																																																																						
B	boulder, (rock)																																																																						
F	forest																																																																						
G	glacier, (rock)																																																																						
P	grassland																																																																						
Pe	peat																																																																						
D	Deuterium																																																																						
O	Oxygen-18																																																																						
T	Tritium																																																																						
I	isotope used for transit time calcul.																																																																						
i	geochem. indicators																																																																						
A	< 20																																																																						
(A)	seasonal, annual average																																																																						
B	20-40																																																																						
C	40-80																																																																						
D	>80																																																																						
BM	binomial model																																																																						
DM	dispersive model																																																																						
EM	exponential model																																																																						
EPM	exp./piston flow m.																																																																						

Acronyms of journals etc. :

AF	Aqua Fennica
DGM	Deutsche Gewässerkundliche Mitteilungen
GWA	Gas, Wasser, Abwasser
HP	Hydrological Processes
HSJ	Hydrological Sciences Journal
JH	Journal of Hydrology
JHH	Journal of Hydrology and Hydromechanics
LU	Landschaftsökologie und Umweltforschung, TU Braunschweig
MCU	Marie Curie University, Paris
NH	Nordic Hydrology

NHP	Nordic Hydrological Programme Report, Oslo
RIG	Rivista Italiana di Geofisica e Scienze Affini
SBH	Steirische Beiträge zur Hydrogeologie
SUWT	Proc. 5th SUWT, Inst. Geol. Min. Explor., Athens
TNO	TNO Committee on Hydrological Research, The Hague
TUBS	Technical University Braunschweig, Inst. Geogr. & Geoecol.
UN	Technical Documents in Hydrology, UNESCO, Paris
UUR	Uppsala University Report Series A
WASP	Water, Air and Soil Pollution
WRR	Water Resources Research
ZGG	Zeitschrift für Gletscherkunde und Glazialgeologie

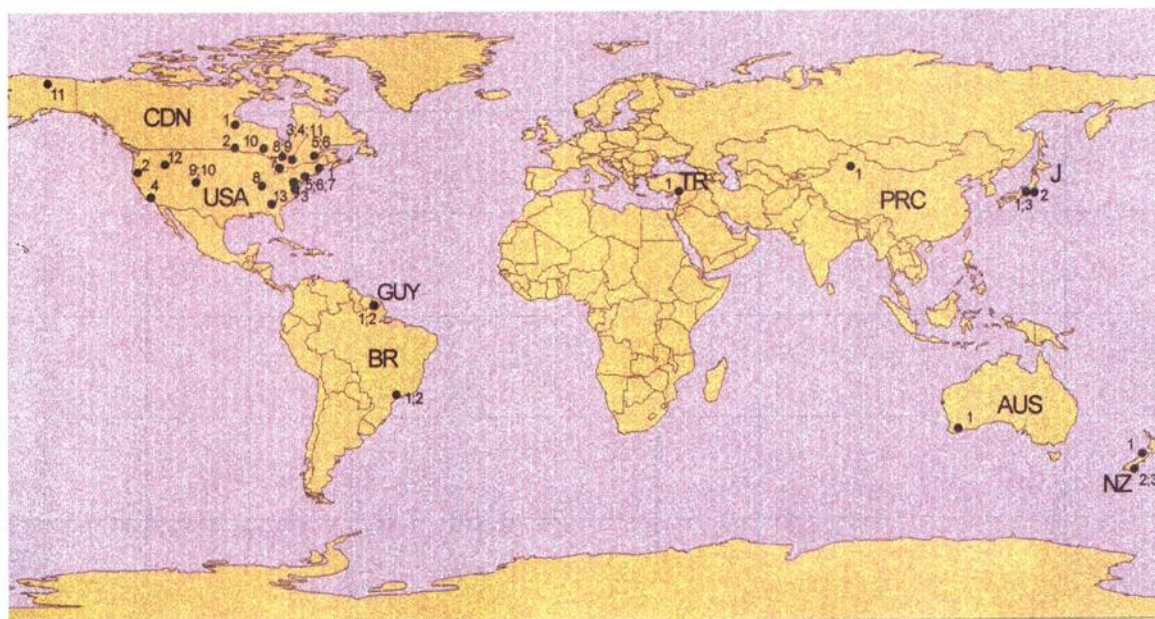

Figure 1 : Global distribution of isotope hydrological catchment studies (cf. Table 1). Europe is shown separately in Figure 2.

Figure 1 : Répartition géographique (Monde) des bassins utilisés dans la revue sur les analyses isotopiques. L'Europe est présentée séparément à la Figure 2.

Consequently, the stable isotopes have been used more and more for mean transit time calculations, but reliable results are then restricted to younger model ages of 4-5 years, even in the case of the most significant seasonal isotopic input variation. Since the stable isotope technique cannot completely replace ³H isotopes for determining mean transit times of water, expectation is high for the development of other techniques e.g. using ⁸⁵Kr, in which large samples of 0.2 m³ of water and expensive analyses are needed, however. Moreover, ³He, which is together with β-radiation the decay product of tritium, has proved to be a reliable but not very practicable tracer. However, in the case of ambiguous ³H results

(recent or >100 yrs.), the combined use of ^3He and ^3H ($^3\text{He}/^3\text{H}$ method) may be advantageous. From these considerations it follows that ^3H is difficult to substitute as a hydrological tracer in the water cycle.

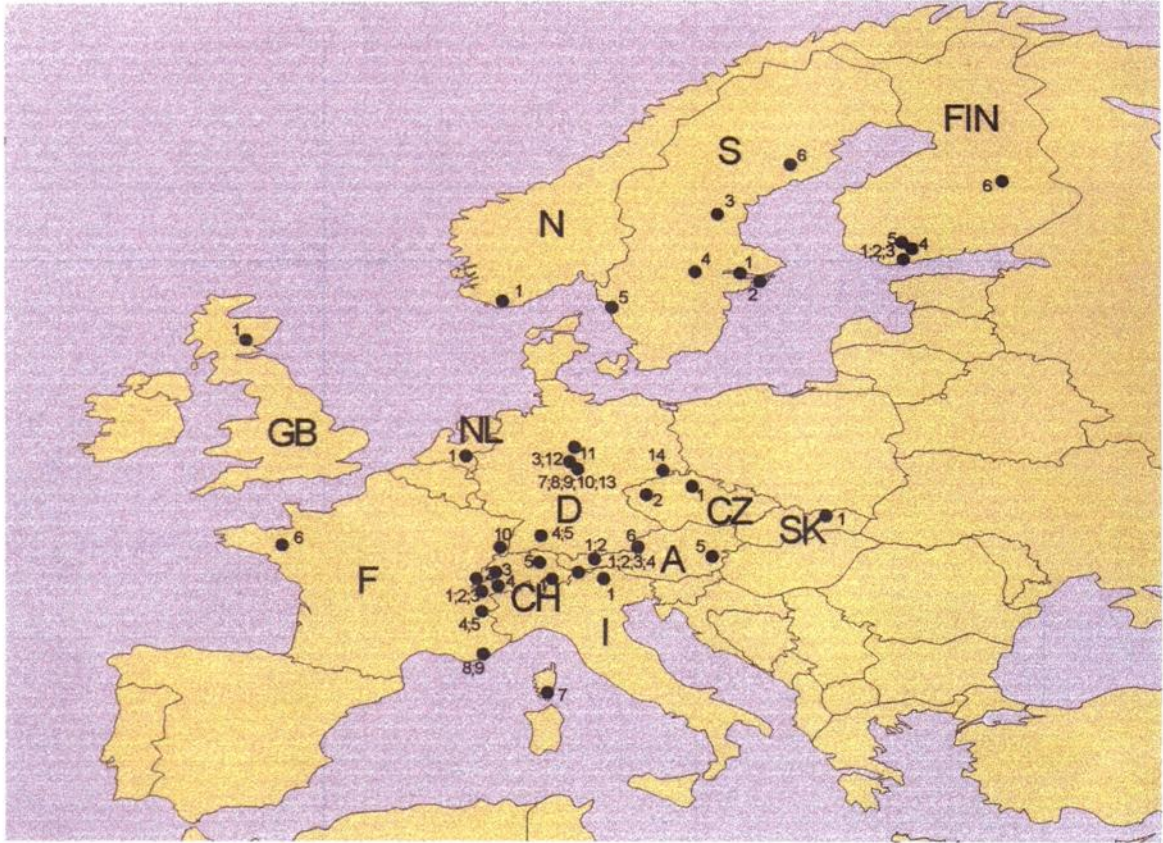

Figure 2 : Geographical distribution of isotope hydrological catchment studies (cf. Table 1) over Europe.

Figure 2 : Répartition géographique (détail de l'Europe) des bassins utilisés dans la revue sur les analyses isotopiques.

The surface areas of the isotope hydrological study basins mentioned in Table 1 are rather evenly distributed : 23 cases of <math> < 1 \text{ km}^2</math>, 27 of 1-5 $\text{km}^2</math>, 20 of 5-20 $\text{km}^2</math>, which all can be considered as being process scale; and 17 of >20 $\text{km}^2</math>. A similar relative distribution is found in the cited focal isotope hydrological study areas, thus confining the applications of the isotope technique from plot scale to regional meso-scale catchments.$$$

Almost 3/4 of the study catchments represent mountainous environments, with highlands of middle mountain character dominating, i.e. elevation ranges of at least several hundreds of meters. With regard to geological conditions 2/3 of the catchments represent hard rock conditions of different but predominantly fractured Paleozoic rock formations. However, this means that with respect to mean transit time computations the dual porosity case applies with t_i instead of t_o , which is the target parameter. Lowland conditions generally coincide with loose sedimentary substrates of Pleistocene glacial origin. In some cases it seems that only shallow covering strata of bedrock have been of interest to researchers, which means that description of geological conditions was rather incomplete. A similar observation is true for soils, which are of even less concern for many authors.

With regard to land use, study catchments are located in the broad zonation range; from glaciated high-alpine environments with rock areas, boulder fields and meadows (~10%) through forested mountain

regions (50%) which closely correlate with the highland topography of study areas, to peaty or forested or agricultural lowlands, although the latter are largely underrepresented. In the meridional direction, most ecozones are represented, starting with Nordic permafrost environments, crossing mid-latitude forest and grassland (steppe, prairie) zones, Mediterranean and dry continental subtropical zones, and finally coming to tropical rainforests.

Summary of results

Hydrograph separation : Direct flow proportions

According to Table 1, subsurface pre-event water (very often identical with groundwater) rather than event water dominates the generation of rain and melt flood hydrographs, in agreement with the earlier status reports mentioned above. The exact proportions found for Table 1 are : d of up to 20% in 35% of all entries, from 20-40% in 31%, from 40-80 in 28% and >80% in 6% of cases (for n=127). This means that most frequently only minor, say <10-20%, of total runoff would rapidly leave a catchment within hours to days. As a consequence, it is repeatedly and strongly advised that conditions for application of classical runoff formation concepts should be very carefully checked before interpreting catchment water and matter balances. Such concepts should be revised, or better ignored in such applications. Another consequence concerns quite small proportions of actual input, of the order of <5%, which leave a catchment immediately under such circumstances, as will be shown in section 2 of Lepistö et al. contribution, together with the variation of direct runoff proportion and runoff formation mechanisms in central European study basins.

Minor direct runoff proportions concern all time scales, i.e. peak discharge conditions, single events, seasonal and annual means, and all types of storm, snowmelt and mixed rain on melting snow cover events. In addition to glaciated catchments, which appear to be affected by highest direct flow proportions, several wetlands and some clayey but obviously subdrained agricultural catchments also have d values lying distinctly above the average. Moderate to low direct flow proportions seem to be typical mainly in forested Central European and eastern US highlands. Unfortunately, the publications mentioned in Table 1 generally do not provide sufficient information about physiographic and experimental boundary conditions, thus making further discussion and comparative evaluation of isotope hydrological findings difficult or even impossible without additional inquiries.

As far as methodological progress is concerned with respect to the hydrograph separation, the attempts made by Kennedy et al. (1986), DeWalle et al. (1988) and McDonnell (1990; see reference list, Table 1) should be pointed out for assigning specific isotopic signatures to soil water, thus allowing application of an isotopic three-component model. It is suggested to refine this approach rather than introduce different geochemical indicators of assumed equal status as was done in several recent studies. The only veritable isotopic three-component separation with two independent tracers (^3H , ^2H) was performed for Vernagtferner Glacier catchment (A-4, Table 1), Oetzal Alps, Austria (Oerter et al., 1980 ; see also Stichler and Herrmann, 1982), where tritium-free ice, and firn and snow meltwater were distinguished.

Mean transit times (t_0 ; t_1)

In Central Europe, there is a distinct concentration of mean transit time investigations, as derived from environmental isotopes. In the case of the findings which are compiled in Table 1, scepticism might arise when considering the warning initial remarks with respect to the meaning of transit times found from DM in the case of dual porosity storage media. Such media are quite common, and must be considered in whole catchment systems, i.e. apart from simply mono-porous or karstic aquifers which are sometimes constituents of more complex systems. In fact there are many examples in which the results represent t_1 rather than t_0 and, therefore, overestimate t_0 , storage volume of mobile water V_m , and effective porosity n_{er} .

One such fallacy concerns a forested low to medium-alpine Lainbachtal catchment with an elevation of up to 1800 m (D-1, Table 1) made up of fractured bedrock (Triassic limestones and dolomites, Cretaceous sandstones and shales) and Pleistocene lacustrine glacial deposits, which is one of the most extensively investigated Central European isotope hydrological study basins. Nevertheless, isotope hydrological findings are rather reliable and confirm that both flow models (EM; DM) and both isotopes (^3H ; ^2H) yield identical results with transit times (t_t) in the order of 2-2.4 years (Maloszewski et al., 1983; ref. list in Table 1). A similar good correlation was observed in high-alpine Wimbachtal catchment of up to 2710 m elevation (D-6, Maloszewski et al., 1992; ref. list in Table 1) 100 km east of Lainbachtal (cf. Fig. 2), with a well developed subsurface karst system and t_t between 4.0-4.1 years as determined using both isotopes ^3H and ^{18}O .

In this context it is worth mentioning that the dual porosity problem for transit time determination was sufficiently solved for the case of the Lange Bramke highland catchment of 0.76 km² situated in the Harz Mountains. The retardation factor R_p , detected from both of the weighted porosities (n_p ; n_r) according to eq. (5), amounts to 1.45 for the fractured rock groundwater system. Accordingly, from $t_t=1.75$ years, $t_o=1.2$ years (eq. 5) was found for this reservoir.

Both alpine catchments approximately delimit the margins for mean transit times (t_t) according to Table 1: longer residence times of 3-4.5 yrs concern high alpine areas, and shorter times of 1.5-2.5 yrs seem typical for lower alpine areas and highlands. In conclusion, mean transit times constitute valuable additional information which allows to derive subsurface storage capacities, and can support time-dependent assessments of geohydrochemical system behaviour. The latter is for example being demonstrated in the Harz Mountains, in the research catchments D-3 and D-7 to D-12 (cf. Table 1) with low subsurface buffering capacities but sufficiently high mean residence times (t_t) of 2.5-3.5 years, to allow groundwater pH-values in the order of 7, despite of continuing acid rain input and soil acidification. Therefore, it is proposed to extend such joint isotopic and geohydrochemical system approaches, but also to coordinate them better.

Hydrological processes in forested catchments

Processus hydrologiques des bassins forestiers

A. Lepistö, L. Andersson, A. Herrmann, L. Holko

1 Introduction

In humid regions chemical flux and cycling are intimately linked to the hydrological cycle. Small catchments provide a natural framework for various types of research, e.g. studies concerning nutrient leaching and cycling, mass balances, effects of land use change and hydrological processes. Catchment investigations have evolved significantly over recent decades; they have become more sophisticated than comparisons of paired catchment outputs, incorporating multiple basins and catchment manipulation, as well as within-basin process studies. In addition, there is now considerably more emphasis on the aspects of local and global environmental change. The complex interactions between hydrology, chemistry and ecology have ensured that process studies remain a vital element of catchment studies, with catchment outputs providing an integration of within-site processes (Whitehead and Robinson, 1993). A fundamental premise of many hydrochemical studies is that hydrological processes - the source, pathway and residence time of water - in a catchment exert a strong control over the water chemistry (e.g. Hooper and Shoemaker, 1986; Whitehead et al., 1986). One of the keys in any attempt to understand variability in catchment outputs is runoff generation processes. Episodic acidification of streams by acid rain or snow is one example of a runoff-related process problem. Another is the link between forest management (cuttings, drainage), streamflow generation and nutrient leaching.

Runoff generation mechanisms in a forested catchment

In the 1960s, Hewlett and Hibbert (1967) put forward the variable source area concept of runoff generation as a basis for understanding the catchment response to storm events. This dynamic framework for storm runoff generation was based on the notions that infiltration capacity is seldom a limiting factor in forested environments, and that *subsurface stormflow* rather than overland flow is capable of making a significant contribution to the flood hydrograph. Betson (1964) defined *contributing area* as the area of a catchment contributing to storm runoff. This means that the contributing sub-area in some way causes an increase of streamflow. Dunne and Black (1970) pointed to the ability of the source (contributing) area to generate saturation overland flow plus return flow, whereas the remainder of the catchment acts mainly as a reservoir during storms to provide baseflow after the storm and to maintain the wet areas. Modeling (Smith and Hebbert, 1983) and field experiments from hydrometric and environmental tracer studies (e.g. Wheeler et al., 1991) support the idea of a continuum in both spatial and temporal occurrence of infiltration-excess overland flow, saturation overland flow and subsurface stormflow within individual catchments under different conditions of rainfall, antecedent soil moisture and intensity of land use impacts (Bonell, 1993).

In different geographical and climatic conditions, an enormous variability in dominating runoff generation mechanisms could be expected. In Europe, conditions vary e.g. from the deep porous soils of Central Europe underlain by porous karst bedrock, to the Nordic shallow till soils with extended peaty areas, underlain by tight granite bedrock.

Environmental isotope methods and modeling as tools for understanding processes

Reviews of the nature of environmental isotopes and of their use in hydrograph separations have been provided by e.g. Rodhe (1987), Sklash (1990), Herrmann (1993), Buttle (1994) and Herrmann (this volume). Analyses of the chemical or isotopic composition of streamwater during runoff events provide information on the integrated result of the various processes contributing to streamflow generation. In forested areas, it is clear from the streamflow isotopic signatures that substantial proportions, often 50-90%, of storm hydrographs consist of pre-event water (Herrmann, 1993 ; Buttle, 1994), at least in catchments where infiltration capacities are high and rainfall intensities low, which is usually the case in forests in humid temperate and boreal latitudes. One challenge is how to interpret the hydrograph separation results spatially. Which parts of the catchment are the most important sources of 'new' water, generated from recent meltwater or precipitation ?

Environmental isotope data can be useful in estimating the areal extent of overland flow (surface-saturated) contributing areas (Sklash, 1990), but spatial interpretations in the literature are very sparse. On the basis of isotope methods, Rodhe (1987) estimated discharge areas of 0.2-17%, with a median value of 3%, for 14 snowmelt events in forested catchments in Sweden. Eshleman et al. (1993) found that estimates of new water-contributing areas determined from chemical hydrograph separations were consistent with estimates of areas of likely surface saturation (e.g. perennial channels, open water and riparian wetland areas), based on field observations and topographic maps. Lepistö (1994) found that the annual dynamics of saturated contributing areas in a forested catchment estimated with isotope methods and TOPMODEL (Beven et al., 1995) were comparable.

The recognition that spatial variations in soil moisture, and therefore runoff producing areas, are driven by topographic gradients has led to the recent rapid developments in topographically and physically based hydrological models, based on digital terrain models (Moore et al., 1991). Such spatial process models, e.g. TOPMODEL, have the ability to indicate the distribution of contributing areas. These areas are vulnerable to disturbance because of preferential waterlogging and the associated runoff generation and erosion (Bonell, 1993). They may have a higher threat of leaching of nutrients from the soils to watercourses, discussed further in section 5.

Hydrological process studies within the FRIEND project 5

Within the FRIEND project 5, the first objective was to generate a greater understanding and synthesis of the physical processes and mechanisms responsible for runoff formation, and of variation in flow components in different physiographic and climatic conditions. Local geomorphological, geological and climatic conditions may have a major impact on direct runoff formation. In this review paper, variability of the direct runoff fraction, as obtained from isotope studies in catchments in Central Europe and in Nordic conditions, is discussed. Particular attention is directed towards runoff formation and ecological sensitivity in mountainous environments in the Czech Republic and Slovakia. The second objective of the project, to investigate the links between hydrological processes and nutrient leaching, is accomplished by a review of recent investigations in the field with emphasis on nitrate-N.

2 Variability of the direct runoff component and related runoff mechanisms in Central Europe

Runoff formation is key ecohydrological process and its adequate knowledge and representation should be a basic interest with respect to reliable numerical, hydrodynamic catchment modeling, geochemical budgeting and regionalising process-oriented hydrological information. The following evaluation of the variability of direct runoff in Central Europe, derived from environmental isotope techniques making use of ^2H and ^{18}O and formerly also of ^3H , and related runoff mechanisms have been developed during the past 25 years, as a result of sometimes very multidisciplinary and therefore costly

focal research projects ; see status reports by Stichler and Herrmann (1982) and Herrmann (1993).

Major study areas

According to a review by Stichler and Herrmann (1985), core isotope hydrological projects in Central Europe are mainly located in the High Alps and in the Bavarian Pre-Alps in the south, and in the Harz mountains at the northern edge of Central European Highlands; including famous research catchments of glaciated Vernagtbach in Tyrol, Austria, situated above timberline (cf. A-4 in Figure 2 ; Table 1 ; Table 2), and Lainbach (D-1) and Lange Bramke (D-3) in Germany. The relevant catchment characteristics are compiled in Table 2. Since findings on direct flow (event water) proportions from isotopic hydrograph separations are supported by hydraulic information about corresponding subsurface reservoirs of complementary indirect (pre-event) flow components, i.e. mean transit times (t_0 ; t ; cf. section 2 of Herrmann contribution), storage volumes of mobile water or effective porosity, the most meaningful mean transit times have also been added to Table 2.

Supplementary knowledge of value with respect to regionalisation purposes is obtained from other research catchments located a little away from this cross-section, i.e. again from south to north : Dischma close to Davos, Switzerland, slightly glaciated and just reaching the timberline (CH-1) ; Bavarian medium and high-alpine Kreidenbach (D-2) and Wimbach (D-6) catchments, the latter being not very typical because of its extraordinary coarse and therefore extremely permeable valley filling which permits surface flow only under extreme conditions; Goldersbach (D-4) and Kirnbach (D-5) of the southern Jurassic limestone and marl highlands ; and finally the most recently included Große Schacht catchments (D-7 to D-10, D-12) of the Harz Mountains. Altogether, Central Europe probably has the most dense network of isotope hydrological research catchments of the world. However, one should observe that the region is most diversified regarding for instance topography, hydrogeological conditions, soils, land use patterns and multiple anthropogenic impact in general.

Direct flow component

One common hydrological feature of all forested, Central European isotope hydrological study catchments is the distinctly minor direct flow component on all time scales between single events, seasons and years, regardless of input origin (rain or melt water), relief and hydrogeological condition, and valid for more than one order of magnitude in surface area. This conclusion can easily be reached from Table 2. Accordingly, the largest quantities of actual inputs will infiltrate, thus contributing to the recharge of subsurface reservoirs. According to Herrmann (1994), lateral water fluxes within the unsaturated soil zone directed towards the streamline network can be limited to scarce cases of stratified slopes. The corresponding flux is called 'interflow' by system hydrologists. However, this term should be avoided in our physically-sound context. Further, in most cases this component is very small, or even negligible.

A most remarkable consequence of these isotopical findings is that only a minor fraction of an actual input leaves the catchment within some hours. This fraction has been evaluated to be much less than 5% of the actual input on average in the Lange Bramke catchment. These are facts which should not be simply ignored by traditional hydrologists or water management investigators. On the other hand, researchers should try to convince sceptics by collecting additional independent evidences, thus also creating the starting point for new innovative research. Another frequent approach is nowadays well designed collaborative research on these very complex environmental systems, conducted by hydrologists, geochemists and biologists (e.g. Moldan and Cerný, 1994).

Table 2 : Direct runoff proportions and mean transit times for isotope hydrological study catchments in Central Europe
Table 2 : Proportions d'écoulements directs et temps de transfert moyens à partir des analyses isotopiques de bassin faites en Europe Centrale.

Code No.	Author, Year/Reference	Name	Country	Geographical coordinates		Surface area (km ²)	Altitude interval (m a.m.s.l.)	Geology/Soils	Land use (% of area)	Indicator used ¹	Direct runoff %				Isotope	g (t) ²	t ₁ ; t ₂ (Yrs.)	Remarks	
				Lat.	Long.						of total events	of seasonal/annual means (period)	storm	melt					
A-4	Oerter, Rauer, Stiehler 1980/Proc. Int. Congr. Alp. Mét. Aix-les-Bains	Vernagtach	Austria	46.53 N	10.56 E	114	2640-3628	gneiss, phyllite, amphibolite/regosol; ranker	84% glacier	H-3, H-2, cond	43 ³			x			³ dir. snow-firn-icewater		
CH-1	Martinec, Oeschger, Schotterer, Siegenthaler, Nuti, Tougiorgi 1978/79/Rivista Ital. Geofis. Sci. Aff. 5	Dischma	Switzerland	46.54 N	09.52 E	433	1668-3146	gneiss, phyllite/ranker, peat, braun earth	<3% glaciers 3% forest/pine pasture & grassland, rock	H-3 ³ , O-18	11	38-48 (snowmelt 1971, 1973-75)		x	H-3	EM DM BM	4.0 4.8 3.0	⁴ I, II represent separate subsurface reservoirs, e.g. unsaturated and saturated zones ³ indicator used for runoff (%) of seasonal/annual means ⁵ including even H-3 ⁶ rain on snow ⁷ preliminary approximations ⁸ % ⁹ unsat. soil zone ¹⁰ groundwater with RF (retardation factor) 1.45 ¹¹ groundw. with RF 1.2	
D-1	Stiehler, Herrmann 1978/Dt. Gewässerkd. Mitt. 22	Lainbach	Germany	47.39 N	11.29 E	188	670-1801	Triassic limestone & dolomite; Cretac. sandstone & shale; Pleistoc. glacial (lacustr.) deposits/rendzina, ranker, braun earth	80% forest & wood (spruce, mixed spruce-deciduous species); alpine pasture & grassland, rock	0-18	12			x	H-3	EM	2.2		
	H-2 ³									10-30	14-28 (winter 35-47 (summer 1976-78) 30-36 (year)		x	H-2	DM I ³ DM II ³ EM DM I ³ calc. II ³	2.4 0.8 7.5 2.1 0.6 6.6			
	H-3, H-2 ³ , cond, ion									15-25		x							
D-2	Eden, Prösl, Stiehler 1982/Proc. Berne Symp.	Kreidenbach	Germany	47.26 N	11.16 E	18	1020-1360	dolomite; moraines /rendzina, braun earth	93% mixed forest	0-18 ³ , cond ³ , ion	25 50	50 (1980-81)	x	x	0-18, dyes	EM EM I ³ EM II ³	1.4 0.1 5.3		
D-3	Stiehler, Herrmann 1982/Berne Symp. 1982	Lange Bramke	Germany	51.48 N	10.25 E	8	543- 700	Lower Devonian sandstones and shales/(podzolic) braun earth	90% Norwegian spruce	H-2	20			x	x ²	H-3 H-2	EM EM	2 ³ 1.9 ³	
	10% grassland								0-18 ³	20 20	10 (1980-86) ³		x	H-3 H-3	ODM ODM	2.7 ³ 4.2 ³			
D-4	Körner, Agster, Einsele, Stiehler 1986/DFG/Einsele (eds.), VCH Weinheim	Goldersbach	Germany	48.36 N	09.06 E	1191	Δ 93 Δ 168	limestone, shale, sandstone, marls/podzolic braun earth; gleysols	90 % forested (oak, beech; spruce)	H-2 H-2	35 40			x x					
D-5	D-5	Kimbach																	
D-6	Maloszewski, Rauer, Trimbom, Herrmann, Rau 1992/J. Hydrol. 140	Wimbach	Germany	47.33 N	12.55 E	334	636-2713	limestone, dolomite/rendzina, podsollic brown earth	pine, mixed forest (spruce, fir, pine, beech, sycamore); 80% rock, fan talus, outwashed plain	0-18	<5				H-3 0-18	EM ODM EM ODM	4.1 4.0 ³ 4.0 4.0 ³	average 1988-90	
D-7	Sommerhäuser 1994/Dipl. Thesis	Gr. Schacht	Germany	51.44 N	10.26 E	9.55	341- 861	Paleozoic quartzite, sandstone, shale, diabase, schist/silty podzolic braun earth, gleyic sols	90-100% forested (Norway spruce; mixed deciduous forest)	0-18 0-18, cond	10-15 10-15 ¹³				x x	H-3 H-3	EM EM	2.5 4.0	¹³ (15-20) from cond
D-8	Inst. Geogr. Geoecol. TU	Gr. Mollental				1.49	435- 822								x	H-3	EM	1.0	
D-9	Braunschweig	Kl. Mollental				2.02	430- 861								x	H-3	EM	2.5	
D-10		Alte Riefensbeck				6.0	380- 641								x	H-3	EM	2.5	
D-12		Haugental				0.7	450-612								-	H-3	EM	2.5	

Groundwater recharge rates

Another consequence of the isotope studies concerns mean annual groundwater recharge rates, which are 2-3 times higher than traditional estimates if referring to the active groundwater volume. The latter is identical with the pre-event water in the two-component case. Therefore, to maintain the quantitative input-output balance of a catchment, considerable subsurface reservoirs are sometimes necessary. They can easily be assessed for steady-state conditions by introducing the mean transit time of water (t_0 ; cf. Table 2), and knowing the groundwater recharge or discharge. Theoretically, minor direct flow proportions should, under otherwise equal conditions, correspond to higher transit times of pre-event water. However, Table 2 shows that this is not often the case in reality where transit times amount to about 4 years under high-alpine conditions and 2-3 years for any other catchments with dominating fractured rock groundwater systems, but with the exception of the Harz catchments D-8 and D-9. Accordingly, for instance the lengths of subsurface flow lines and hydraulic conductivities and connectivities within fractured rock groundwater systems, which may considerably differ within short distances, should also play important roles. Furthermore, one should consider that in the case of the flow model DM only those mean transit times of the tracer (t_1) apply which are R_p (=retardation factor) times higher than t_0 (Eq. 5, section 2 of Herrmann contribution). On the other hand, in all cases considered here the assumed subsurface mobile water volumes and effective porosities fit rather well with the natural conditions.

Runoff mechanisms

Finally, the isotopic findings require a specific mechanism of runoff formation in frequent cases of flood hydrographs being dominantly generated by pre-event water, with considerable groundwater recharge rates as just mentioned. The relevant processes in this context were recently evaluated in detail by Herrmann (1994), using Harz catchments D-3 and D-9 in which special groundwater observation wells have been drilled for this purpose. Accordingly, most processes that are normally given separately in this context (e.g. Buttle, 1994) apply at best jointly but specifically coupled, i.e. groundwater ridging, translatory flow, macropore flow and saturation overland flow. Even kinematic waves cannot be excluded from the outset as a reliable modeling approach. This means that in forested mountainous catchment systems of Central Europe, a specific mixture of a large variety of water fluxes, i.e. any relevant surface but preferably subsurface fluxes which have been mobilised by an input impulse, contributes to runoff formation process.

In fact, groundwater table-discharge relationships are extremely hysteretic in all cases of storm and melt events studied here, thus indicating that runoff formation really is a highly complex process, with groundwater exfiltration being a related, extremely non-linear, time-variant key mechanism. Consequently, when studying runoff formation we should concentrate on hydraulic aquifer behaviour. For example, the following explanation can be offered for such hysteretic conditions in the case of dual porosity discussed here (Herrmann, 1994):

In the initial phase of flood formation which is identical with the rising limbs of hydrographs and hysteretic loops, and probably also during the short-term quasi-stationary state during peak discharge, mainly macropores, i.e. fractures and fissures, are draining. Increasing groundwater table accompanied by hydraulic head's increase, is mainly due to pressure transfer with the infiltration process, because of the low conductivities of the unsaturated zones. With the recession flow which coincides with falling limbs of both the hydrograph and the hysteretic loop, microfissures and the porous matrix begin to contribute increasingly to runoff at a relatively high level. Another kind of explanation refers to the distance between subsurface source and exfiltration area, i.e. aquifer sections near the stream are responsible for rising limbs and become less important with the extension of the flood wave supply system towards more distant contributing areas. Subsurface storage losses are immediately compensated by seepage of infiltration water through macropores, fissures and fractures, thus establishing a short-circuit between terrain surface and aquifers. Since exfiltration is a whole year's process, groundwater recharge is also, at least in the humid mid-latitudes.

3 Variability of direct runoff in Nordic conditions

Typical properties of Nordic forests

Typical for forested areas in Nordic conditions is the dominance of *till soils*, which constitute more than 90% of the surface sediments (Haldorsen, 1990). In till soils, saturated hydraulic conductivity is often high at the soil surface and decreases rapidly with depth (Lundin, 1990). The hydraulic conductivity of a given soil layer decreases rapidly as the larger pores drain, leading to a strong co-variation between the degree of saturation and the transmissivity of a soil profile. During conditions of low flow, water drains slowly from the catchment because the most conductive superficial soil layers are unsaturated. Fresh inputs of rainfall to the soil increase the saturated depth in the soil profile and reduce the proportion of air-filled pores in the unsaturated zone, leading to an increase in runoff from the catchment (Bishop, 1991).

Another factor typical of Nordic forests is the occurrence of *peatlands*. Peatlands are poorly drained areas in a transitional state between terrestrial and aquatic systems, where the water table is periodically at or near the surface or the land is covered by water. Originally, peatlands covered about one third of the area of Finland; comprehensive drainage has changed over half of the peatland areas to forested-like areas (Seuna, 1988). In Sweden, approximately 15% of the land is covered by a peat layer with a vertical extension of at least 0.5 m. Flow within peatlands is difficult to constrain because of the highly variable properties of the peatland sediments. Organic layers near the surface (the acrotelm layer) can be highly porous, with a hydraulic conductivity as high as three orders of magnitude greater than that in the deeper peatland horizons; most water flow occurs primarily through the acrotelm. As a consequence of the limited storage capacity of the surface layers, surface discharge from peatlands responds rapidly to changes in inputs, with little or no detention or regulation of streamflow (Verry and Boelter, 1978). In flat, peaty areas the direct, near-surface runoff component may have a significant role in runoff generation. In the following section, generalisations from isotope hydrograph separation studies conducted in catchments with varying percentages of peatlands are discussed.

Factors affecting the direct fraction of runoff

The tracer-based hydrograph separation technique normally involves a two-component mixing model for the catchment output. Most of the isotope hydrograph separations performed worldwide (n=92), reviewed by Buttle (1994), have been conducted in small, upland forested basins in mid- and high-latitude regions (e.g. Scandinavia, eastern North America, Australasia). Regionalizations of the large number of available isotopic hydrograph separation studies are, however, very rare. How is the direct, event water fraction related to major catchment and climatological/hydrological characteristics? It can be assumed that e.g. topography, soil type, or volumes of a snowmelt or rainfall event would affect the proportion of the direct runoff.

The collected information on catchment characteristics, on hydroclimatic conditions and on fractions of direct runoff for 14 forested catchments and 23 snowmelt events in Finland, Sweden and Norway (Table 3) was used in the following evaluation of factors affecting the direct runoff component.

Melting of snow is the most important physical process in the formation of spring floods in northern conditions. In Finland, the *snow water equivalent (SWE)* at the beginning of melting is usually 6-10 times greater than the total precipitation during the snowmelt period (Kuusisto, 1984). The SWE thus defines the potential for the spring flood, and higher amounts of SWE before melting allow higher amounts of water discharging as 'new' direct runoff. In Fig. 3a, the fraction of direct runoff during the melt period is given as a function of the SWE in the beginning of the snowmelt. The volume of the snowmelt was shown to affect the direct runoff fraction but the variability was considerable.

Table 3 : Direct runoff proportions during snowmelt periods in isotope hydrological research catchments in Nordic countries.
Table 3 : Proportions d'écoulements directs pendant les périodes de fonte des neiges à partir d'analyses isotopiques faites dans les pays nordiques.

Catchment	Country	Author/ Year	Area km ²	Mean slope %	Soil cover				Year/ melt season	Water eq. of snow before melt mm	Max. runoff during event l/skm ²	Direct runoff %
					Mineral %	Organic %	Fine soils %	Open bedrock %				
Aspåsen	Sweden	S-3 Rodhe 1987	0.17	16	>98	0	0	<2	1981	246	218	58
Buskbäcken	"	S-4 "	1.84	7	>86	9	0	<5	1980	98	128	47
"	"	" "							1981	110	123	41
Gårdsjön F1	"	S-5 "	0.036	14	53	0	0	47	1980	30	67	28
" F2	"	" "	0.040	15	40	13	0	47	1980	25	43	33
" F3	"	" "	0.028	18	63	5	0	32	1980	56	71	20
Nåsten	"	S-1 "	6.6	4	55	4	16	25	1979	88	47	23
"	"	" "							1982	75	108	43
Stormyra	"	S-2 "	4.0	10	13	8	12	67	1979	110	76	14
"	"	" "							1982	85	209	44
Svartberget	Övre	S-6 "	0.20	7	60	40	0	0	1981	200	-	59
"	"	" "							1982	205	98	41
" Västra	"	" "	0.16		80	20	0	0	1981,82	200-205	-	36
" Nedre	"	" "	0.50	7	67	33	0	0	1981	200	156	53
"	"	" "							1982	205	158	49
Djurvasslan	"	Jacks et al. 1986	33.5		50	50	-	-	1985		350	70-80 ¹
Teeressuonoja	Finland	Lepistö & Seuna 1990	0.69	10	78	13	7	2	1985	109	39	15
"	"	FIN-4 "							1987		14	17
"	"	Bengtsson et al. 1991							1988	116	43	22
Hovi ²	"	FIN-5 Bengtsson et al. 1992	0.12	3	0	0	100	0	1992	111	150	92
Liuhapuro	"	FIN-6 Lepistö 1995	1.7	5	52	48	0	0	1989	234	242	63
"	"	" "							1992	196	318	53
Birkenes	Norway	N-1 Christophersen et al. 1984	0.41		43	7	0	~50	1983	160	210	30

¹exact hydrograph separation not performed by the authors, estimated range from the figure

²totally agricultural catchment, not included in the analysis

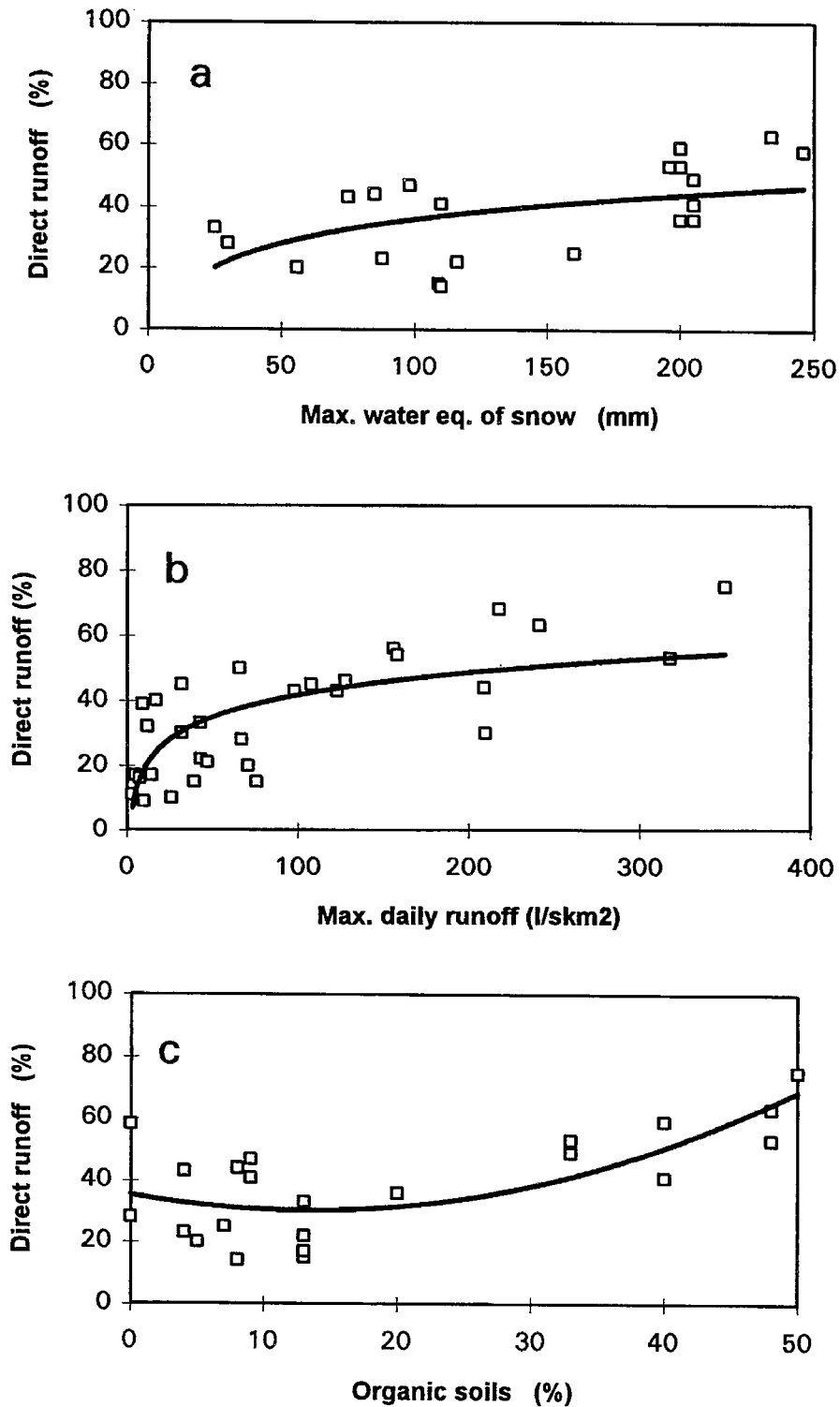

Figure 3 : Proportion of direct flow as estimated by isotopic hydrograph separation during snowmelt periods, in forested catchments in Nordic countries. Proportions are given as a function of **a)** maximum water equivalent of snow SWE before the melt period, **b)** max. daily runoff during the event, and **c)** percentage of organic soils in the catchment.

Figure 3 : Proportion d'écoulement direct, telle qu'estimée par séparation isotopique des hydrogrames, durant les périodes de fonte des neiges, dans des bassins forestiers des pays nordiques. Les proportions sont données en fonction : **a)** du maximum de l'équivalent en eau de la neige (SWE) avant la période de fonte, **b)** du maximum d'écoulement journalier pendant l'événement, et, **c)** du pourcentage de sols humiques dans le bassin.

Rodhe (1987) found that, in 10 forested catchments in Sweden, the closest relationship between groundwater (pre-event water) fraction and a single hydrological variable was that found with maximum runoff of the event. In this study with four catchments more, *maximum streamflow during the melt period* explained 51% of the variation of the event water fraction (Fig 3b). Some of the spring floods were composed of two or more distinct melting periods (Rodhe, 1987), each of which was included in the analysis. The snowmelt periods of Liuhapuro (FIN-6) in eastern Finland (Lepistö, 1995) and Djurvasslan in central Sweden (Jacks et al., 1986) had maximum daily runoffs above $300 \text{ l s}^{-1} \text{ km}^{-2}$, providing information about the relationship during these high runoff intensities. The relationship curve is assumed to increase slightly when the runoff intensities are high, but event water fractions of over 80% are probable only in urban, agricultural or permafrost catchments (Buttle, 1994).

The percentage of *organic soils* explained 54% of the variation of the direct component of runoff (Fig. 3c). However, a wide variety of different types of peatlands increases the variability of direct runoff. For example, the Svartberget catchments (upper and lower, S-6) had considerable proportions (33-40%) of open bog areas whereas e.g. Liuhapuro (FIN-6) had 29% of spruce mires and 18% of open bogs. A Swedish catchment (Aspåsen, S-3) with no peatlands at all also had a high event water fraction of 58%. In this case, a relatively high slope of 16% might have affected the rapid flow paths of the runoff and the corresponding high event water fraction. In general, it is suggested that surface storages and surface-saturated areas in peatlands play a major role in explaining direct runoff, i.e. high event water contributions to the stream.

In theory, a parabolic distribution is probable, with the highest event water fractions (direct flow) on the one hand in mineral, shallow soil catchments with steep topography, and on the other hand in flat, surface flow-dominated bogs. The average *slope* of a catchment was tested as one possible explaining variable but showed a highly scattered variation with no clear relationship with the direct runoff proportion.

4 Hydrological processes and modeling in mountainous environments

Mountains control much of the redistribution of the atmospheric moisture over the continent. They are the source areas of all the large river systems of the world. The hydrological conditions and processes in mountain areas are characterised by wide spatial variability. There are considerable vertical gradients of climatic factors, such as temperature, air humidity, precipitation and radiation components. The storage of solid precipitation in the snow cover and its release during the melting periods determines the spring flow regime typical for these areas.

In the following sections, recent studies carried out in some mountainous catchments in central Europe are reviewed and discussed. The main focus is on the runoff formation as determined from isotope studies and/or modeling.

Runoff formation as determined from isotope studies and modeling

Runoff separation studies were carried out in the Jalovecky Creek catchment (Western Tatra Mountains, Slovakia, SK-1) using different methods: Isotopic runoff separation (Holko, 1995) gave event water contributions of 0-30% with discharge below $1.5 \text{ m}^3 \text{ s}^{-1}$ and 10-60% with higher discharges (Figure 4). The long-term groundwater proportion of runoff was estimated to approximately 50%, using a method based on the relationship between groundwater table and the stream discharge (Kliner and Knezek, 1974). The average contribution of direct (surface) runoff during a period of six hydrological years was calculated as 16% (Holko and Lepistö, 1997), using a modified version of the distributed hydrological TOPMODEL (Beven and Kirkby, 1979). The modelled areal extent of the contributing areas during a single runoff event was similar to that calculated from isotopic runoff separation. The location of contributing areas was partially in agreement with the empirical

observations (Holko and Lepistö, 1997). An application of the conceptual SAC-SMA (Sacramento soil moisture accounting) model (Burnash et al., 1973) for the hydrological years 1990-1993 gave a calculated proportion of 11% of the total runoff which was composed of direct runoff and runoff from impermeable zones (Holko et al., 1996).

According to runoff simulations with the conceptual SAC-SMA model and the physically based BROOK_90 model (Federer, 1990) carried out by Buchtele et al. (1996) in the Sumava and Orlice Mountains (Czech Republic) and in the Harz Mountains (Germany), also in basins underlain by crystalline bedrock, the baseflow component represented more than 50% of the total runoff.

Comparison of the results from various methods suggests that the simultaneous use of empirical methods and modeling may be very valuable; if results are similar they will strengthen each other, if they differ, there is a need for further investigations. However, some field studies indicate that the model results should always be verified.

As an example, TOPMODEL predictions of the extension of contributing areas in the Uhlirská catchment (Jizera Mountains, Czech Republic) compared well with results of a field survey (Blazkova and Kulasova, 1995). The infiltration rates in the catchment showed very high variation from very permeable soils in which preferential routes of water exist, to highly impermeable, clogged soils which appear mainly in the clearcut areas (Bubenickova and Hancvencl, 1990).

On the other hand, soil moisture variability in the root zone in the Jalovecký Creek catchment showed a different spatial pattern of soil moisture compared with that indicated by the spatial distribution of the topographic index used in connection with the TOPMODEL (Kostka, 1995). One possible explanation for this difference is spatial distribution of forest transpiration and water uptake processes, which were not included in the model. Although the measured soil water content in the upper soil layer was not directly comparable with the soil water content in the whole unsaturated zone calculated by TOPMODEL, these results indicate that the role of vegetation in water partitioning and runoff formation in the catchment should be taken into account.

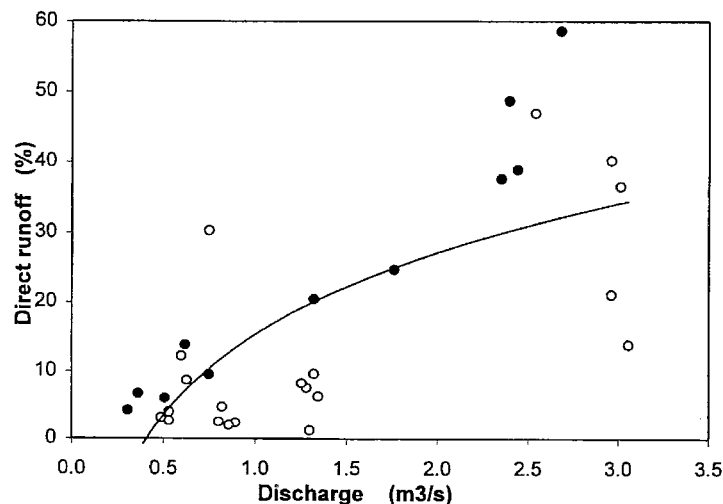

Figure 4 : Proportion of direct flow vs. daily flow, as estimated from isotopic runoff separation in Jalovecký Creek catchment (SK-1 in Table 6.1) during the snowmelt periods 1992 (white dots) and 1993 (black dots); catchment mean flow is about $0.6 \text{ m}^3 \text{ s}^{-1}$.

Figure 4 : Proportion des écoulements directs vs débits journaliers, tels qu'estimés par séparation isotopique des écoulements dans le bassin Jalovecký Creek (SK-1) pendant les périodes de fonte des neiges de 1992 (points blancs) et 1993 (points noirs) ; l'écoulement moyen du bassin est de l'ordre de $0,6 \text{ m}^3 \text{ s}^{-1}$

Ecological sensitivity of mountainous areas - case studies from the Jizera Mountains

Owing to their topography and related dynamics, mountainous areas are far more ecologically sensitive than other landscape types. An evident example can be seen in the Black Triangle - one of the most air polluted areas in Europe situated at the borders of the Czech Republic, Germany and Poland. The Jizera Mountains are situated in this Black Triangle area.

About 90% of the Jizera mountains have been deforested since 1990. Spruce forests damaged by acid rain have been substituted by grass and young plants of coniferous and deciduous trees. Experimental methods and mathematical modeling were used to assess the hydrological effects of this vegetation change. Relationships between soil moisture, evapotranspiration and runoff generation were assessed using conceptual and physically based mathematical catchment models. Below, the most significant results are summarized:

1. Decreased evapotranspiration due to the deforestation causes higher runoff volumes. Two different modeling approaches seem to confirm this conclusion :

- higher runoff was simulated after deforestation, in an experimental catchment where deforestation was caused by a heavy storm, using the conceptual SAC-SMA model (Tesar *et al.*, 1994)
- lower runoff from forest compared with grassland, due to higher evapotranspiration from forest, was simulated using the physically based BROOK' 90 model (Buchtele *et al.*, 1995)

2. Both the models above confirmed the dominant role of winter precipitation in recovering groundwater storage and the seasonal shift in the annual runoff. This must be considered when assessing the possible hydrological effects of climatic change.

3. The existence of asynchronous hydrological and agricultural droughts was shown to be relatively common for these catchments in central Europe (Buchtele *et al.*, 1995).

Soil and water acidification, transport of chemicals and changes in aquatic biota are investigated using extended meteorological and hydrological networks in seven small catchments in the Jizera Mountains. In the Uhrlinska catchment, the frequency version of TOPMODEL is being applied (Blazkova and Beven, 1995) to simulate lateral water fluxes from various soil depths, to be used as inputs to the chemical PROFILE model (Sverdrup *et al.*, 1994). The model will be used to predict the response of river water quality to high atmospheric depositions (Vilimec, 1995).

5 Links between hydrological processes and nutrient leaching

There exists a considerable short-term variation in nutrient concentrations in small forest streams, which is influenced by water flow paths and transit times, but also by seasonal variability of biological processes (e.g. Roberts *et al.*, 1984 ; Burt *et al.*, 1988 ; Turner and Macpherson, 1990 ; Andersson and Sundblad, 1992). However, when nutrient export from a catchment is estimated, calculations are often based on linear interpolation from weekly or monthly monitoring programmes. The estimated exports may therefore be very different from the actual values. Better estimates of temporal and spatial variability of exports would thus be obtained by increasing considerably the frequency of sampling, in order to obtain information about the actual fluctuations. Since fluctuations are very dynamic in small catchments, especially if there are no lakes, this is usually not economically realistic. An alternative is to incorporate knowledge about links between temporal dynamics of streamflow generation and other dynamic processes, such as biological activity, into models. Hydrological factors could be e.g. flow volume, the fraction of event water, the extension of contributing areas, or a division between flow increase and decrease. Incorporation of knowledge about such links might improve the accuracy and precision of estimates of nutrient exports. An example of this is the incorporation of links between flow increase and nitrate-N concentrations (Arheimer *et al.*, 1996) into a hydrochemical model of nitrogen

transport (Arheimer and Wittgren, 1994).

It must also be considered that relationships between seasonality, hydrological dynamics and concentrations depend on catchment characteristics (e.g. soil type, land use, altitude, topography). Such characteristics are strongly related to e.g. the dominating nitrogen transformation (Vitousek et al., 1979), as well as to the transport mechanisms (Dillon and Molot, 1990 ; Lepistö et al., 1995). Below, some recent studies which consider relationships between streamflow and nitrate-N concentrations and exports are reviewed. The emphasis is to discuss detected relationships on the one hand and catchment characteristics related to these links on the other.

Seasonal patterns

Most of the seasonal variations in streamwater chemistry are governed by climatic (e.g. quantity and chemical composition of precipitation, air and soil temperature) and biotic factors (e.g. nutrient assimilation, mineralization, nitrification). Climatic and biotic factors are strongly interrelated; the biotic factors depend on climate, and e.g. the actual evapotranspiration depends on biological activity. Seasonal variations of water quality are therefore largely governed by the processes taking place in the terrestrial part of the catchment (Moldan and Cerný, 1994). This should be remembered when interpolating non-frequent concentration data.

In a study based on 10 years of data from 20 forested catchments in Finland and Sweden (Arheimer et al., 1996), it was shown that calculated loads can be strongly over- or underestimated if samples taken during certain flow situations are linearly interpolated, without considering hydrological or biological dynamics. Most of the investigated catchments (Arheimer et al., 1996) had low annual mean nitrate-N concentrations, and therefore dilution could be expected during high flows. For the catchments with lowest annual mean concentrations, up to 14 times lower median concentrations were observed during high flow compared with low flow, due to nutrient uptake. Catchments with higher concentrations during high flows were shown to have relatively high annual mean concentration levels. Similar results of links between average concentrations and discharge in forest streams have been reported from American surveys (Driscoll et al., 1989). Catchments with higher concentrations during high flow were situated in the south and at low altitudes, where fine soils are more common. They had significantly higher mean annual temperatures and mean annual nitrate-N concentrations, which indicated that more plant nutrients were available in the soils. Since nitrogen conservation in a Boreal ecosystem is reduced at increased nutrient availability (Vitousek et al., 1979 ; Plymale et al., 1987), these catchments are more disposed to leakage. During high flow, hydraulic forces will induce washout of soil nitrate-N, causing higher concentrations in the streamwater.

The influence of flow situation on concentrations

Part of the variance in streamwater concentration is usually a function of stream flow. This comes about as a result of two different kinds of physical phenomena (e.g. Helsel and Hirsch, 1992). One is *dilution* : a solute may be delivered to the stream at a reasonably constant rate, whereas the flow changes over time. The result of this situation is a decrease in concentration with increasing flow. The other process is *wash-off* : a solute, sediment, or a constituent attached to sediment can be delivered to the stream primarily from (surface-saturation) overland flow, or from streambank erosion. In these cases, concentrations as well as fluxes tend to increase with increasing flow (Helsel and Hirsch, 1992).

Higher concentrations during periods of increasing flow, compared with stable or decreasing flow are probable due to a flushing effect. Arheimer et al. (1996) found significantly higher nitrate-N concentrations during increasing flow in 8 of 20 investigated catchments in spring. In autumn, however, only one catchment revealed significantly higher concentrations. This difference provides evidence of the importance of pollutants released from the snowpack. Seasonal snow cover accumulates chemical

species (nutrients and pollutants deposited by snowfalls) which are discharged during melt, together with accumulated ions from the catchment soils. During the melt season, both the hydrological and hydrogeochemical fluxes in northern ecosystems are maximal.

Saturated, contributing areas affecting nitrate-N leaching

With regard to leaching of nutrients, those nutrients associated with suspended solids (e.g. particulate P) probably leach more, the higher is the fraction of direct runoff, due to erosion forces. Diluted nutrients (e.g. $\text{NO}_3\text{-N}$) may behave differently. High percentage of organic soils seemed to be one factor which contributed to high amounts of recent, event water but low amounts of released nitrate from a catchment (Lepistö, 1996). It is probable that enlarging of the saturated, contributing areas during a flow event increase the possibilities for leaching, but that a prolonged extension of saturated areas allows retention processes (e.g. denitrification) to dominate the N cycling. Further studies should be devoted to these questions.

During flow events, atmospheric nitrogen deposition on saturated contributing areas may contribute more or less instantly to the nitrogen leaching (Löfgren, 1991). This might be an important link between high stream density and increased nitrate-N leaching from forest soils. In a study of regional variability of nitrogen export, based on 20 forested catchments in Finland and Sweden (Lepistö *et al.*, 1995), it was shown that stream density was the only hydrology-related variable affecting the variability of nitrate-N export. In another study (Lepistö, 1994), it was hypothesised that contributing, saturated areas may have a high potential to regulate nutrient fluxes between upland areas and the stream. Groundwater is frequently present at a shallow depth beneath the contributing (riparian) area and vegetation and soil processes may therefore modify the chemistry of groundwater before it enters the stream (Swanson *et al.*, 1982 ; Lowrance *et al.*, 1985). Monthly variation of nitrate-N concentrations was modelled by assuming that concentration levels from non-contributing areas would be similar to concentration levels in shallow groundwater, whereas concentration levels from contributing areas would be similar to those found in the precipitation. This simple, two-component model could approximately explain the annual dynamics of nitrate-N concentrations (Lepistö, 1994). In an ongoing study, this work is being further developed, based on an intensive sampling programme of spatial (ground and surface water) and temporal variations of nitrogen concentrations, other chemical variables and ^{18}O samples, in one Finnish and one Swedish catchment.

Process studies in agricultural catchments

Etudes des processus dans certains bassins versants agricoles

P.M.M. Warmerdam, G.A.P.H. van den Eertwegh, V. Elias, G.H. de Rooij, M. Sir, M. Tesar

1 Introduction

Well-instrumented research catchments provide an important basis for developing a better understanding of hydrological processes. These relatively small catchments also constitute an important tool for studying anthropogenic effects on hydrological and environmental processes. For a further development of rainfall-runoff models and a better understanding of the processes of solute transport, improved knowledge of runoff processes and stream flow generation is needed. In many humid region catchments, rapid response to precipitation is frequently observed, which apparently indicates rapid subsurface flow pathways to groundwater and further to the stream channels.

Within the FRIEND project 5, processes of streamflow generation and their effect on solute transport were studied in agricultural catchments. The progress of study in the Hupselse Beek catchment (NL-1) in the Netherlands and in the experimental catchments in the Sumava mountains in the Czech Republic is reported here. In the Hupselse catchment the water balance of the area and the chemical composition of the stream water were analysed with particular emphasis on quantifying runoff components and their residence times. At experimental sites of three small catchments in the Sumava mountains, water loss components from the unsaturated soil profile were quantified using the hydropedological balance. Results obtained with the SWAP93 model, which simulates the transient flow in a heterogeneous soil profile, are also discussed.

Preferential flow as caused by flow through macropores or by instability of the wetting front can exert a dominating role on rapid subsurface flow and solute transport in the unsaturated zone. The results of a recently developed model for calculating convective transport, and of experiments on the spatial distribution of drainage in a lysimeter are reported. These results illustrate the major effect of preferential flow.

2 Water and nutrient budget of a rural catchment in the Netherlands

Experimental setup

The purpose of the study is to analyse the water balance and stream water composition data in order to quantify discharge components and travel times in the Hupselse Beek (NL-1 in Table 1) research catchment. The 'Hupselse beek' is a small stream draining a shallow aquifer in a 650 ha catchment area in the eastern part of The Netherlands. Over 95% of the soils in the area are sandy. The catchment area is extensively drained by subsurface drains and ditches. About 70% of the area is covered by grass, 20% by corn and 10% by forest.

Local measurements of daily precipitation were made using a rain gauge at the soil surface level. Daily reference-crop evapotranspiration rates according to Makkink were calculated from local meteorological data (Makkink, 1960), and potential evapotranspiration rates using crop factors (Feddes et al., 1996). Reduction in evapotranspiration was estimated using measured groundwater levels and cumulative precipitation excess during the summer. Stream discharge was measured continuously at the outlet of the catchment, using an H-flume. Stream water composition was measured using time-proportional, and from 1990 onwards flow-proportional sampling schemes.

The hydrology of the catchment is characterized by rapid response of groundwater levels and stream discharge to precipitation excess due to the low storage capacity of the soils and possibly to preferential flow in the unsaturated zone. The annual water balance of the area and the loads for chloride, nitrogen and phosphorus were calculated for the period April 1985 - March 1994.

Results

The annual water balances are presented in Table 4, the years being run from the beginning of April to the end of March. The cumulative calculated change of storage is close to zero. On average, 60% of the water input of the area is lost by evapotranspiration and 40% by runoff. The annual stream solute loads are shown in Table 4 (van den Eertwegh, 1996).

The main sources of the solutes mentioned are manure and fertilizers. Of the total-N applied to the soil surface, 20% is lost to the stream by leaching. Less than 1% of the total-P applied is lost to the surface water system by surface runoff and leaching. The combination of discharge rate, chloride, nitrate and sulphate concentrations in the stream water indicates nitrate reduction due to pyrite oxidation in the relatively deep parts of the groundwater system. It is estimated that 60% of the nitrate in the relatively deep groundwater is lost by denitrification (van den Eertwegh, 1997).

Table 4 : Annual water balance of the 'Hupselse beek' catchment and chloride and nutrient loads during the period April 1985 - March 1994.

Table 4 : Bilans annuels du bassin Hupselse, et flux de solutés, période d'avril 1985 à mars 1994.

Year	Precipitation	Actual ET	Runoff	Change of storage	Chloride load	total-N load	total-P load
	mm a ⁻¹	mm a ⁻¹	mm a ⁻¹	mm a ⁻¹	kg ha ⁻¹ a ⁻¹	kg ha ⁻¹ a ⁻¹	kg ha ⁻¹ a ⁻¹
1985	863	500	331	+32	147	107	0.91
1986	803	524	306	-27	152	118	1.36
1987	1063	483	544	+36	221	172	1.27
1988	753	499	275	-21	115	95	0.88
1989	697	547	173	-23	91	83	0.44
1990	778	548	267	-37	129	115	0.67
1991	727	498	220	+9	108	92	0.55
1992	759	550	261	-52	124	102	0.36
1993	1144	488	572	+84	192	147	0.99

The composition of the shallow groundwater, mainly drained by subsurface drains and ditches, shows dilution effects for nitrate and chloride within the drainage season (Figure 5). Summertime chloride concentrations are about 50 mg l⁻¹, whereas during the start of the winter season concentrations increase rapidly. This increase may be caused by the contribution of near-stream zones or preferential flow in the unsaturated zone. On the basis of chloride and nitrate-N concentrations in stream water in the summer and winter seasons, it is estimated that 35% of the annual discharge consists of relatively deep groundwater, 60% of shallow groundwater and 5% of surface runoff. Residence times of the shallow groundwater are estimated to vary from several months to a maximum of 5 years. About 55% of the deep groundwater has a residence time of less than 5 years before it drains into the rivulet. The nitrate and phosphate concentrations in stream water have decreased with time since 1990 (van den Eertwegh, 1997). Over 80% of the annual nitrogen load of the stream is determined by shallow groundwater, and almost 40% of the annual phosphorus load by surface runoff.

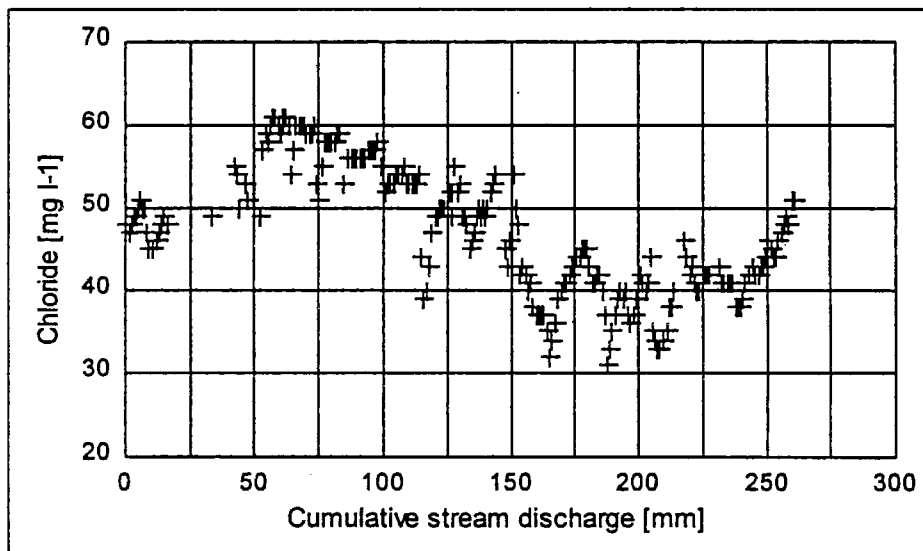

Figure 5 : Chloride concentrations vs. cumulative stream flow in the Hupselse Beek (NL-1 in Table 1) during April 1992 - March 1993.

Figure 5 : Concentrations de chlorure en eau courante d'avril 1992 à mars 1993.

3 Loss components from soil profiles in the Sumava mountains as determined by the hydro pedological balance and simulated by the SWAP93 model

Hydropedological balance

A long-term field experiment aiming at calculating water loss components from the active soil profile during the growing season is being conducted by the Institute of Hydrodynamics of the Academy of Sciences of the Czech Republic (supported by the Czech Grant Agency). Data were collected from experimental plots of three small catchments (arable land, meadow and spruce forest) situated in the Sumava mountains (South Bohemia, Czech Republic) during the period 1983-1995. The experimental plots have been described elsewhere (Tesar, 1996). The uptake of water from the soil (actual evapotranspiration) and the percolation of soil water to strata underlying the root zone were estimated with the aid of the hydro pedological balance from time series of tensiometric measurements made at 2-day intervals and from precipitation totals per day. Retention curves were used in the recalculation of tensiometric data to soil moisture content, and thus also to the volume of soil water. The retention curves of individual genetic soil horizons were obtained by the inverse solution of Richard's equation using the method described in the study by Sir et al. (1988) and expressed in accordance with van Genuchten and Nielsen (1985) and Sir et al. (1985). The structure of the soil profile and the depth of the root zone were established with the aid of profile pits. The withdrawal of water from the root zone, designated as LOSS (L), was obtained by balancing precipitation and the volumes of water present in the root zone of the soil at 2-day intervals. The analysis of tensiometric and precipitation data showed that leakage of soil water occurred to the strata underlying the root zone at several intervals during the balance period (Prazak et al., 1992 ; Sir et al., 1996a, b). The volume of water thus drained away is termed OUTPUT (O). The amount of water taken up by the roots for transpiration was then obtained by the equation $T = \text{LOSS} - \text{OUTPUT}$. At the experimental plots used for this study surface runoff was not observed.

Simulations using the SWAP93 model

The loss components from the soil profile were also calculated using the SWAP93 model, which is an upgraded version of the earlier SWATRE model (Soil Water and Actual Transpiration Rate, Extended). This model (Belmans et al., 1983 ; Wesseling et al., 1989) is a water balance model simulating the transient vertical flow in a heterogeneous soil profile. The soil-water flow module describes the one-dimensional (vertical), transient, unsaturated water flow in a heterogeneous soil-root system using the Darcy flow equation and the continuity equation (de Jong and Kabat, 1990) with a sink term. The sink term represents the water extraction rate by plant roots. Under non-optional conditions, i.e., either too dry or too wet, the maximum possible water extraction was reduced by means of the pressure-head dependent function described by de Jong and Kabat (1990). The upper-boundary conditions at the soil surface included daily rainfall and potential evapotranspiration. Free drainage was applied as a bottom-boundary condition. The necessary input data sets were prepared for the SWAP93 model to be applied in the three above-mentioned experimental plots according to the input instruction manual (Broek et al., 1994).

For the purposes of obtaining input data sets for the SWAP93 model, the potential evapotranspiration of the vegetative cover in the vegetation season was calculated as the water requirement for plant cooling by the energy balance. The calculation uses hourly values of air temperature and of global-radiation totals. Properties of the vegetative cover are expressed in terms of two phenomenological constants - effective absorptivity and effective thickness of leaves (or needles). Both are obtained by calibration. The applicability of the proposed calculation was subjected to experimental verification in the mountain areas of the Sumava range. This verification and a full description of the proposed method were presented by Prazak et al. (1994, 1996).

Results

The proposed hydro-pedological balance was applied in the three experimental plots differing in land utilization (arable land, meadow and forest) for the time period 1983-1995. Parameters of retention curves and values of saturated hydraulic conductivity were expressed according to van Genuchten and Nielsen (1985) and Sir et al. (1985). The values of water balance components over a fortnight were derived from the hydro-pedological balance as the withdrawal of water from the root zone (T) and calculated as the requirement of water for cooling plants (ET) in each plot. The leakage of soil water to strata underlying the root zone (O) was also determined. Furthermore, the results of simulation using the SWAP93 model were obtained. The following pressure-head limits, used to characterize the sink-term function, were established during preliminary model-calibration runs : $h_1 = -1$ kPa, $h_2 = -2.5$ kPa, $h_{3L} = -32$ kPa, $h_{3H} = -60$ kPa, $h_4 = -90$ kPa. The results obtained both with the hydro-pedological balance and with the SWAP model were mostly in good agreement. Figure 6 illustrates for example the calculation of the 1985 vegetation season. In this figure, calculated values of water storage, evapotranspiration and leakage obtained with the SWAP93 model are compared with the results of the hydro-pedological balance.

Some discrepancies appear when higher precipitation totals occur in the beginning and in the end of the time interval used. In this case these rainfall events are sometimes not recorded by tensiometers. The results cannot yet be considered as conclusive because the simulations with the SWAP93 model are still in the initial stage. This study clearly shows the important role of soil moisture movement in the hydrological processes of the catchment in the Sumava Mountains.

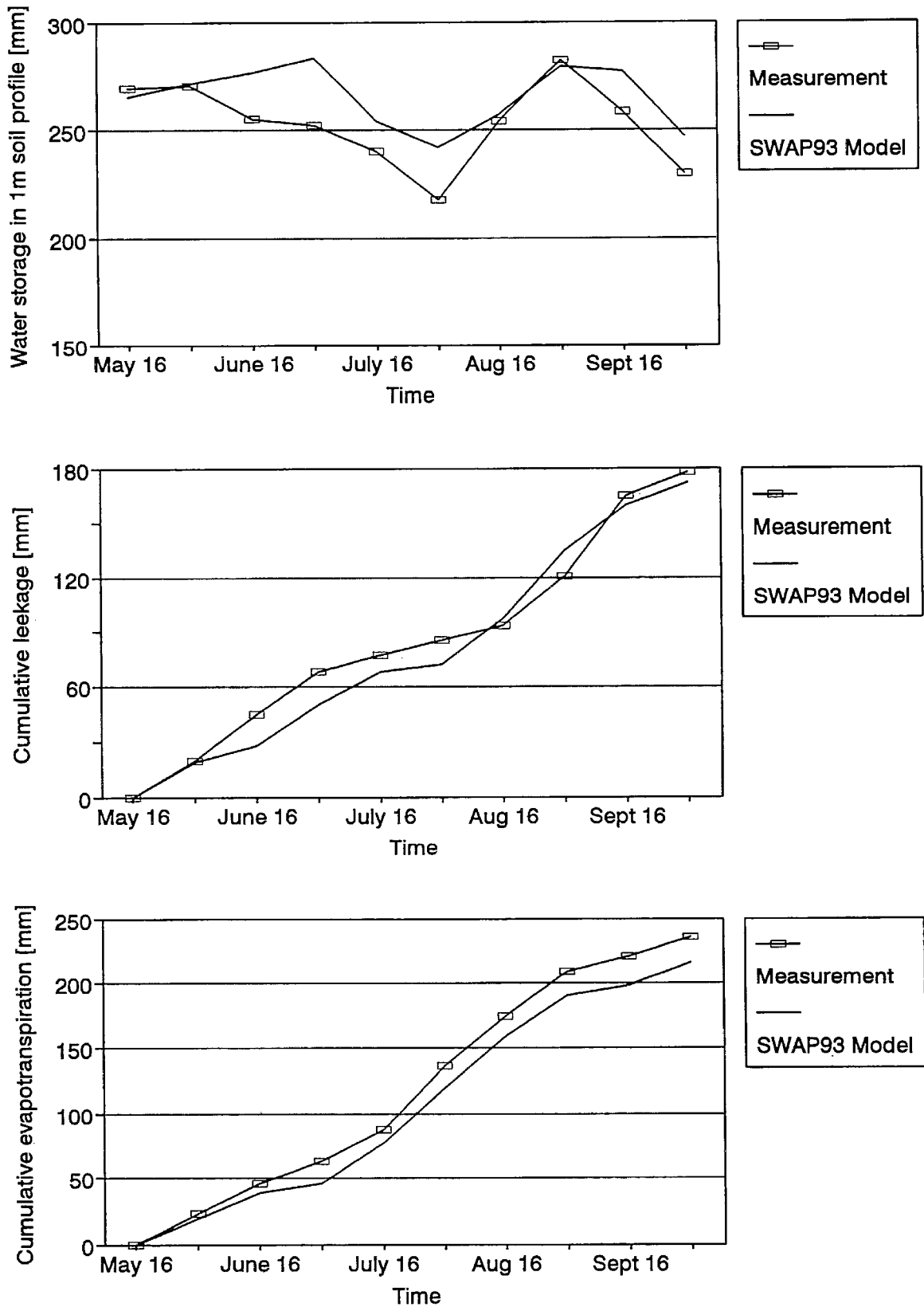

Figure 6 : Soil-water balance and its loss components in the experimental plot Liz (forest) during the vegetation season 1985.

Figure 6 : Bilan de l'eau dans le sol, et ses composantes de perte dans la parcelle expérimentale de Liz (forêt), pendant la saison végétative de 1985.

4 Measurement and modeling of preferential flow due to wetting front instability

The soil has often been regarded as a filter capable of retaining and degrading chemicals applied to it. This filter protects the biosphere as well as underground bodies of fresh water (Gee et al., 1991). However, due to the increasing load of agricultural and industrial chemicals, the filtration capacity of soil is often exceeded, resulting in serious environmental damage (Hillel, 1987; van Genuchten and Leij, 1992). Natural properties of the soil also affect the filtering capacity. Bypass flow rapidly directs water and solutes from the soil surface to the saturated zone, thus severely hampering the decay and adsorption of contaminants. Bypass flow (or preferential flow) can be caused by flow through macropores or by instability of the wetting front. In the latter case, an initially planar wetting front breaks up into well defined preferential flow paths, or fingers, which are much wetter than the surrounding soil (Raats, 1973 ; Starr et al., 1986 ; Glass et al., 1991 ; Glass and Nicholl, 1996). The Dept. of Water Resources of Wageningen Agricultural University has been investigating wetting front instability, especially in soils with a water-repellent toplayer (a condition which strongly enhances wetting front instability, see e.g. Ritsema et al. (1993)) and a shallow groundwater table.

In soils with water-repellent toplayers and groundwater-affected wettable sublayers, a flow pattern develops that consists of three regions, as depicted in Figure 7 (de Rooij, 1995, 1996 ; Ritsema et al., 1993). In the top few centimeters, water flow converges towards the tops of the preferential flow paths. Within the preferential flow paths, water moves vertically downward. In the wettable subsoil, the flow diverges owing to matrix forces. An analytical three-region model was recently developed by de Rooij (1995, 1996) and de Rooij et al. (1996) to calculate the convective transport of an inert tracer in this steady-state flow system.

Calculations with this model showed that the wettable subsoil largely determines the residence time in the unsaturated zone and the shape of the breakthrough curve. A comparison of model calculations with field data of Ritsema et al. (1993) for a soil with only a thin (26 cm) wettable layer between the water-repellent topsoil and the groundwater level demonstrated that the diverging flow in the wettable subsoil must be taken into account in order to reliably model solute leaching in field soils with water-repellent toplayers (Table 5). On the other hand, if preferential flow was ignored in the calculations altogether, the solute residence time in the unsaturated zone was overestimated by two orders of magnitude, illustrating the large effect which preferential flow can have on solute leaching to the groundwater if a thick layer of wettable material is absent.

A new type of lysimeter was constructed to study the spatial distribution of drainage and solute leaching with a resolution of 5 cm from an undisturbed sandy soil column with a water-repellent toplayer (1.00 m² area, 0.55 m height) (Figure 8 ; de Rooij, 1996). The experiments provided strong support for the concepts underlying the three-region model of preferential flow. Additionally, during an eight-month period of uninterrupted experimentation, unique observations of the long-term dynamics of unsaturated flow were made (Figure 9). Areas of high drainage moved over lateral distances of up to 0.25 m, and the distribution of drainage over different areas with large drainage amounts varied slowly but strongly. The three-region analytical model could reproduce the breakthrough of a chloride pulse reasonably well, even without calibration. In combination with the support provided by the lysimeter data for the underlying concepts, this makes the model a promising starting point for a transient, numerical model for solute transport in fields with water-repellent toplayers.

Table 5 : Amount of drainage required to leach 7% of a bromide pulse for different flow regimes in the soil profile of Ritsema et al. (1993). The observed amount of rainfall required in a field experiment was 0.04 m.

Table 5 : Volume de drainage nécessaire au lessivage de 7% d'une impulsion de bromure, pour différents écoulements. Le total de précipitation était de 40 mm.

Flow regime	Precipitation rate (m d ⁻¹)	Amount of drainage (m)
Stable flow	0.001	0.22
	0.173	0.27
Three-region flow	0.001	0.043
	0.173	0.063
Deep fingers	0.001	0.00043
	0.173	0.022

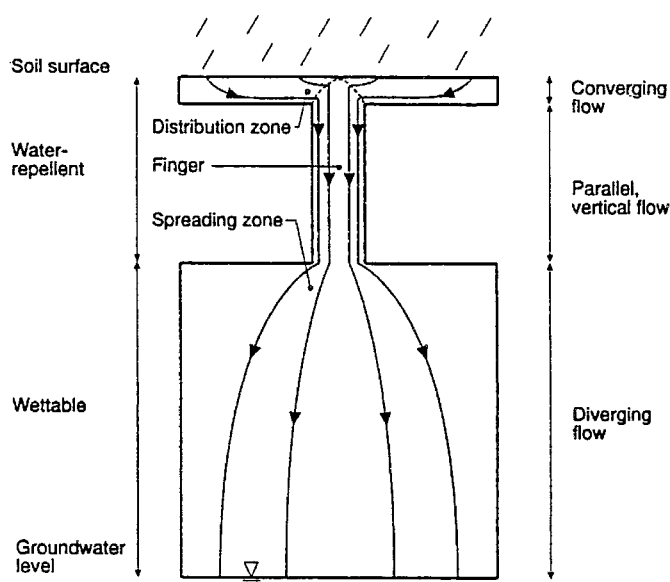

Figure 7 : The flow pattern associated with one finger. The dashed line denotes the boundary between the distribution zone and the finger. The model of De Rooij (1995, 1996) assumes an axisymmetrical flow pattern. From De Rooij and De Vries (1996).

Figure 7 : Schéma des écoulements autour d'un conduit unique (macro-porosité verticale). La ligne tiretée indique la limite entre la zone de distribution (pluie) et la zone d'écoulements concentrés dans la macro-porosité. Le modèle de De Rooij (1995, 1996) suppose un schéma d'écoulement à symétrie axiale.

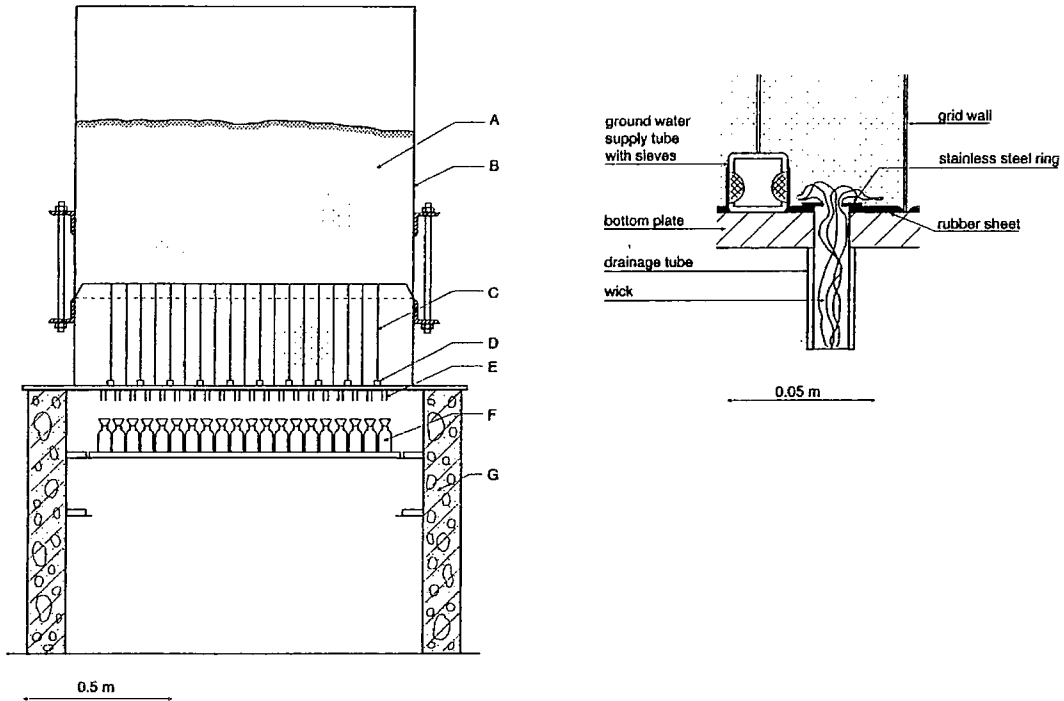

Figure 8 : Cross-section of the lysimeter set-up and a detailed sketch of a drainage compartment. From De Rooij (1996) :A. Soil core, B. Sample cylinder (lysimeter wall), C. Galvanized grid consisting of vertical square steel pipes, E. Drainage outlet, F. Drainage collection flask with funnel on tray, G. Concrete U-shaped support

Figure 8 : Coupes de lysimètre, et structure détaillée d'un élément vertical du niveau de drainage (De Rooij - 1996) : A. Sol, B. Paroi cylindrique du lysimètre, C. Grille galvanisée formant réseau de drains mégailliques verticaux carrés, E. Sortie de drainage, F. Dispositif de recueil des eaux drainées, avec flacons, entonnoirs et plateau, G. Structure support en béton

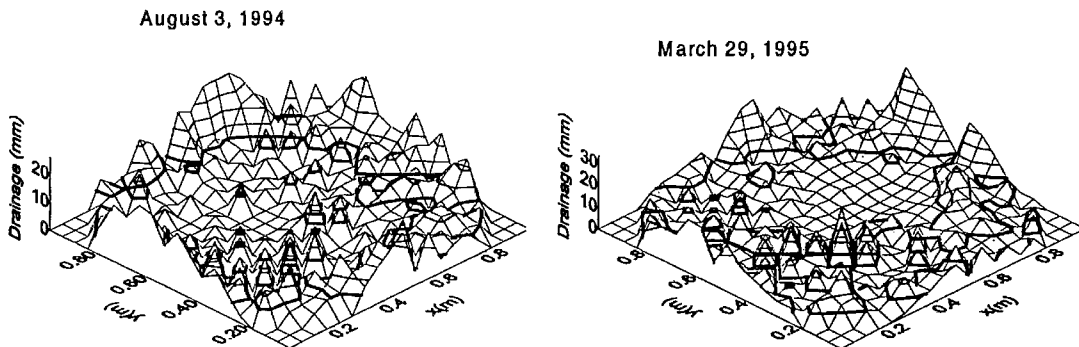

Figure 9 : Spatial distribution of the amount of drainage from the lysimeter on two selected dates. The center of the lysimeter is located at $x = y = 0.5$ m. The average drainage of the entire lysimeter is indicated by a bold contour line. Drainage amounts above the average have contour lines at multiples of 5 mm. From De Rooij (1996).

Figure 9 : Distribution spatiale des drainages localisés du lysimètre, à dates sélectionnées. Le centre du lysimètre est à $x = y = 0.5$ m. Le drainage moyen (spatial) pour tout le lysimètre est représenté par la ligne en gras. Les valeurs supérieures à la moyenne sont représentées par multiples entiers de 5mm.

Modélisation pluie-débit et régionalisation : le programme ERREAU en Côte d'Ivoire

Rainfall-runoff modeling and regionalization : the ERREAU programme in Ivory Coast

E. Servat, B. Kouamé, A. Dezetter, J.E. Paturel

1 Introduction

Dans le cadre du programme ERREAU (Evaluation Régionale des Ressources en EAU), les objectifs que nous visions concernaient l'évaluation des ressources en eau d'une région donnée par la mise au point et l'élaboration d'outils de modélisation. S'ajoutait à cela la contrainte qui était de fournir la meilleure approximation des apports à l'exutoire de bassins versants jaugés ou non, et ce, en se plaçant du point de vue des gestionnaires et des aménageurs. Dans cette optique nous avons fait le choix de ne travailler qu'à l'aide de données dites de "réseau" tant en pluviométrie qu'en hydrométrie. Ce choix a eu pour conséquences immédiates d'imposer, d'une part, un pas de temps de calcul qui ne pouvait être inférieur à la journée et, d'autre part, de travailler sur des bassins versants de taille moyenne (100 à 7000 km²). La prise en compte de ces contraintes (données de réseau, bassins versants d'assez grande taille) a semblé nécessaire pour pouvoir envisager des retombées pratiques rapides de ces travaux en matière d'aménagement et de gestion, bien qu'elle conduise à utiliser des données dont la qualité est parfois difficilement appréciable.

La zone d'application initiale du programme ERREAU était constituée par le Nord-Ouest de la Côte d'Ivoire, c'est-à-dire le secteur délimité par les hauts bassins du Bandama, du Niger et du Sassandra. Cette zone a finalement pu être étendue à l'ensemble de la Côte d'Ivoire, incluant ainsi les zones de transition et de forêt.

2 Données et méthodes

L'économie de la Côte d'Ivoire, pays en développement, est principalement liée à l'agriculture et, à un degré moindre, à une relative industrialisation dont l'énergie est tirée à 60% de l'hydroélectricité. C'est dire l'importance considérable que revêt la disponibilité des ressources en eau. C'est la raison pour laquelle, soucieux d'obtenir des résultats facilement et rapidement utilisables dans le cadre de projets de développement, nous avons privilégié les données enregistrées par les réseaux nationaux (au pas de temps journalier), par rapport aux données denses et à fort coefficient de fiabilité que nous aurions pu tirer des études menées sur bassins versants expérimentaux et représentatifs. Un tel choix, parfois peu "confortable", peut être considéré comme une forme de prix à payer pour mener une recherche en hydrologie que l'on pourrait qualifier de "stratégique" et orientée vers des objectifs de développement et de gestion. Dans le même ordre d'idée, c'est à dire pour des objectifs qui sont ceux que nous venons d'afficher, il est évident qu'en Afrique, au moins, les modèles globaux sont plus intéressants que les modèles distribués de relation pluie-débit, et qu'ils le resteront encore longtemps (Paturel et al., 1995). Ils offrent, en effet, généralement, une simplicité de manipulation très supérieure à celle des modèles distribués. En outre, ceux-ci nécessitent très souvent la connaissance de nombreuses variables dont la détermination est parfois complexe. Sans compter, bien entendu, que dans ces régions la faible densité des réseaux de mesure plaide, à l'évidence, contre une distribution de l'information (pluviométrique en particulier) qui n'aurait que peu de sens.

D'un point de vue pratique, le programme ERREAU a permis la constitution de fichiers pluie-débit opérationnels. Ils couvrent l'ensemble du territoire ivoirien et ont été regroupés au sein d'une base de

données. Facilement accessibles ils constituent donc aujourd'hui une intéressante série de jeux-tests pour les zones de forêt, de transition et de savane.

3 Discussion et conclusions

Concernant l'évaluation des ressources en eau et les outils qui lui sont nécessaires, différentes modélisations des apports ont été envisagées.

Plusieurs formulations permettant d'estimer la lame écoulée annuelle ont été testées (Kouamé, 1992) : relations empiriques basées sur la seule utilisation de l'information "pluviométrie annuelle", ou relations issues d'une approche en régression multiple, elles se montrent toutes assez approximatives, reproduisant avec peu de fiabilité les événements à caractère exceptionnel. Dans la mesure où l'on disposerait de l'information pluviométrique sur l'année considérée et celle qui la précède, certaines des équations que nous proposons permettent, néanmoins, d'avancer un ordre de grandeur tout à fait acceptable en ce qui concerne la lame écoulée. Il est clair, cependant, que la lame écoulée annuelle dépendant de nombreux paramètres autres que la hauteur de pluie annuelle (végétation, répartition de la pluie dans le temps, etc), ces méthodes, au caractère global très marqué, seront toujours limitées dans leurs performances.

Nous nous sommes donc attachés à reconstituer les hydrogrammes annuels au pas de temps mensuel. Nous avons opté, pour cela, et toujours dans l'optique d'un transfert aisé vers les opérateurs du développement, pour un modèle simple basé sur la description du bilan hydrologique, initialement proposé par Snyder (1963). Partis d'un algorithme à neuf paramètres, dont les qualités de robustesse (utilisation des jeux de paramètres calés sur d'autres années) se sont révélées particulièrement faibles, nous avons procédé à une analyse et à une restructuration qui ont abouti à un modèle au pas de temps mensuel à trois paramètres. Les performances de cet algorithme (appelé ici modèle AB2) sont tout à fait satisfaisantes. Il se révèle d'une utilisation robuste dans la majeure partie des cas où nous l'avons utilisé. Ce travail a permis, encore une fois, de poser avec acuité le problème de la juste paramétrisation des modèles pluie-débit. Nombreux sont les algorithmes qui présentent des paramètres en surnombre, et dont l'utilisation en simulation pour l'évaluation de ressources pourrait être envisagée de manière plus fiable, après une analyse et une restructuration du type de celles que nous avons conduites ici.

Le modèle AB2 présentant de bons résultats en zone de forêt et de transition, son utilisation a également été validée en zone de savane. Les résultats de ce test se sont révélés suffisamment probants pour que nous proposons, aujourd'hui, l'utilisation de cet algorithme sur l'ensemble du territoire ivoirien (Kouamé, 1992).

Au pas de temps journalier, seuls les résultats obtenus en zone de savane se sont révélés probants (Dezetter, 1991). Les causes d'un tel échec en zone de forêt en particulier sont vraisemblablement très diverses mais on peut cependant en avancer certaines :

* Les mécanismes complexes de fonctionnement d'une forêt tropicale ne sont pas pris en compte par ces algorithmes : pas de simulation possible du fonctionnement de la litière, pas de prise en considération de l'interception due au couvert végétal, modélisation simpliste de l'ETR, etc.

* Les données de réseaux recueillies au pas de temps journalier sont parfois entachées d'erreurs (cumuls en particulier) qui perturbent l'utilisation de ces algorithmes, alors que leur importance diminue considérablement à de plus grands pas de temps.

En zone de savane, par contre, les résultats obtenus sont assez bons (Servat et Dezetter, 1991). Par ailleurs, l'ensemble des essais réalisés ici en "calage-validation" amène à penser que le calage des modèles conceptuels utilisés ici est loin de n'être fonction que des seules caractéristiques physiques et géomorphologiques intrinsèques des bassins versants. Les caractéristiques climatiques et

physiographiques des années et des bassins considérés ont assurément un rôle important et doivent être, nécessairement, prises en considération dans toute tentative d'explication des valeurs prises par les algorithmes pluie-débit.

La modélisation au pas de temps journalier fait également apparaître, et ce plus nettement qu'aux autres pas de temps, les modifications liées aux facteurs de l'écoulement intervenues depuis le début de la sécheresse à la fin des années 1960. Il est, en effet, pratiquement impossible de valider correctement des calages effectués avant cette date sur des années de sécheresse (post 1970) et réciproquement. Les années 1983-1984, paroxysme de la sécheresse, semblent jouer un rôle identique : calage puis validation de part et d'autre de ces deux années extrêmes du point de vue hydrologique sont généralement peu satisfaisants.

Plusieurs essais de prédétermination des paramètres ont été effectués (Servat et Dezetter, 1993). Seuls ceux réalisés en zone de savane pour les algorithmes au pas de temps journalier se sont révélés positifs. Les équations obtenues font intervenir, principalement, des variables caractéristiques de l'occupation des sols et des indices de répartition des pluies dans l'année. Elles mettent ainsi l'accent, de manière indirecte, sur la nécessité de pouvoir prendre en compte des variables caractéristiques de la couverture végétale proprement dite. Ceci permettrait d'améliorer sensiblement la représentation des phénomènes d'évapotranspiration, primordiaux dans le bilan hydrique.

Les résultats obtenus à l'aide de ces équations sont d'une qualité relativement acceptable en ce qui concerne le modèle GR3 (Edijatno et Michel, 1989). Le comportement du modèle CREC (Guilbot, 1986) est moins satisfaisant (essentiellement du fait d'une paramétrisation moins précise). Cependant ces équations statistiques de prédétermination des paramètres ne permettent guère, actuellement, de s'éloigner d'une certaine "normalité climatique".

A l'issue de ce programme et des réflexions auxquelles nous nous sommes livrées, plusieurs perspectives s'offrent désormais :

* La modélisation au pas de temps mensuel offre certaines garanties quant à la fiabilité des données, tout en conservant un intérêt certain pour les différents opérateurs du développement économique et rural. Il serait donc intéressant de comparer l'approche qui fut la nôtre à une modélisation globale conceptuelle au pas de temps mensuel. Ceci dans un souci de recherche d'un outil le plus fiable possible.

* Bon nombre de projets agronomiques nécessitent la prise en compte des apports au pas de temps décadaire. Nous devrions donc poursuivre et compléter notre approche de la modélisation de la relation pluie-débit à un tel pas de temps, à l'aide d'algorithmes de type bilan ou de type conceptuel.

* Parvenir à une modélisation plus fine et plus satisfaisante des phénomènes d'évapotranspiration. Celle-ci représente, en effet, dans ces régions, une fraction très importante des volumes entrant en jeu dans le bilan hydrologique. Une meilleure prise en compte de ce phénomène apporterait un plus au fonctionnement de ces modèles.

* La prise en compte d'autres variables descriptives des bassins versants au niveau de la définition des équations de prédétermination des paramètres. On peut penser à des caractéristiques de sol, à des indices de végétation ou de croissance de la végétation (à partir d'images satellites par exemple), plus précis que le simple partage en pourcentages de cultures, de savanes, de forêts et d'habitat.

D'une manière plus générale, en Afrique de l'Ouest, et plus particulièrement dans l'ensemble de la sous-région, il est important de multiplier ces travaux de modélisation. De la confrontation de ces multiples expériences et de leurs résultats, acquis dans une grande diversité de situation, il devrait être possible de mieux appréhender les problèmes de la modélisation de la relation pluie-débit, préalable indispensable à toute opération d'évaluation et de gestion des ressources en eau.

Short conclusion

Brève conclusion

P. Seuna, A. Lepistö

Global review of isotope studies. The global distribution of 90 isotope hydrological study catchments indicates their concentration in the northern mid-latitudes, i.e. in the North American continent with southeastern Canada and eastern United States as focal areas, in Central Europe including the Alps, and in Scandinavia. Subsurface pre-event water rather than event water dominates the generation of rain and melt flood hydrographs, in agreement with earlier status reports. Minor direct flow proportions concern all time scales, i.e. peak discharge conditions, single events and both seasonal and annual means, as well as all types of storm events, snowmelt, and mixed rain and snowmelt events. Glaciated catchments seem to have the highest direct flow proportions, and several wetlands and some clayey agricultural catchments also have proportions lying distinctly above the average.

Future applications of the isotope technique should be more extended to mean transit time determinations, which allow calculation of groundwater recharge in connection with long-term separation of direct flow. Since applications of the isotope techniques and particularly hydrograph separation have arrived at a rather nice level of regional diversification, more attention should now be paid to (a) further refinement of the separation technique concerning different origins of pre-event waters in space and time, and (b) more systematic comparison of results obtained from different indicators, i.e. isotopes, chemical compounds or electrical conductivity. Despite the many regional examples, agricultural catchments are hitherto still under-represented. More sub-tropical highland regions could also be considered if there is sufficient annual variation in isotopic input.

Forested catchments. One common hydrological feature of all forested, Central European isotope hydrological study catchments is the distinctly minor direct flow component on all time scales between single events, seasons and years, regardless of input origin (rain or melt water), relief and hydrogeological conditions, and valid for more than one order of magnitude in surface area. The same is also valid in the Nordic conditions with till-dominated, shallow forest soils. The volume of the snowmelt was shown to affect the direct runoff fraction but the variability was considerable. Maximum streamflow during the melt period and the proportion of organic soils both explained about half of the variation of the event water fraction. A large variety of different types of peatlands increases the variability of direct runoff. It is suggested that surface storages and surface-saturated areas in peatlands play a major role in explaining direct runoff, high event water contributions to the stream.

Local geomorphological, geological and climatic conditions may have a major impact on direct runoff. More effort is needed to regionalize information from a large variety of isotopic process studies. Generalization attempts should be conducted in limited geomorphological/geological areas, e.g. Central Europe, Australasia, northern U.S.A./Canada etc.. Incorporation of knowledge about links between dynamics of streamflow generation (e.g. the extension of contributing areas) and other dynamic processes, such as biological activity, might improve the accuracy and precision of estimates of nutrient export, and should increasingly be used in models.

Agricultural catchments. Nutrient losses from agricultural soils have a heavy impact on watercourses. Under modern agricultural practices, maximization of crop outputs is frequently accompanied by high losses of solids (erosion), liquids and gases. Typical for agricultural catchments is a higher proportion of direct flow combined with erosion forces and quicker response to rainfall and meltwater inputs. The residence time of shallow groundwater of the Hupselse catchment in the Netherlands varied between one to several months and five years. About 60% of the annual stream discharge consisted of shallow groundwater and determined about 80% of the annual nitrogen load of the stream water. Surface runoff, which was only 5% of the annual runoff, accounted for almost 40% of the annual phosphorus load. The newly developed energy balance method for the evaluation of potential evapotranspiration can be used to generate input data for the water balance model simulating the

transient vertical flow (SWAP93). The results of simulation were compared with the results obtained by the hydrogeological balance. The model was tested in arable land and meadow catchments and appeared to be useful for prediction of water balance components. Lysimeter studies gave supplementary information on an important flow component, bypass flow (preferential flow), which reduces adsorption of contaminants and may have considerable effects on solute movement. More effort should be devoted to utilizing isotope hydrological techniques also in agricultural catchments in combination with other process studies, and to the linking of this information into the nutrient and solids loss models.

In general, more integrated studies are needed in combined hydrological, isotope hydrological and geochemical investigations. In future, more effort should also be devoted to utilizing isotope-based information of processes in catchment-scale and regional hydrological / hydrochemical models in the assessment of the impacts of environmental changes.

oooo

Bilan global. Les résultats globaux réunis pour près de 90 bassins étudiés à l'aide d'isotopes hydrologiques, concernent surtout les latitudes moyennes du nord : le continent nord-américain avec le sud-est du Canada et l'est des Etats-Unis, l'Europe centrale y compris les Alpes, et la Scandinavie. Les premières séparations des composantes de l'écoulement ont été réalisées avec le tritium ^3H , tandis qu'à présent les isotopes stables deutérium ^2H et ^{18}O dominant. Ces analyses isotopiques sont de plus en plus souvent complétées par des analyses hydrogéochimiques, ce qui indique ainsi également la complexité et la multidisciplinarité croissante de nombre de projets de recherches récents. Les eaux subsuperficielles relativement anciennes dominent largement dans les hydrogrammes d'origine pluviale et de fonte des neiges, par rapport aux eaux venues directement des épisodes générateurs. Ceci en plein accord avec les conclusions antérieures. Ces proportions réduites d'eaux s'écoulant directement concernent toutes les échelles de temps, par exemple les débits de pointe, ou les crues simples, comme les moyennes saisonnières ou annuelles, et tous les types d'averses, de fontes de neige ou d'événements mixtes. En dehors des bassins glaciaires qui semblent présenter les plus grandes proportions d'écoulement direct, plusieurs zones marécageuses, et certains bassins agricoles argileux, ont aussi des valeurs d'écoulement direct qui se situent au dessus de la moyenne.

Régimes forestiers. Une caractéristique hydrologique commune à tous les bassins forestiers d'Europe Centrale analysés avec des isotopes hydrologiques, est cette composante d'écoulement direct minimale à toutes les échelles de temps, depuis les événements élémentaires jusqu'aux saisons et années, quelque soit l'origine des entrées (pluie ou eau de fonte), le relief et les conditions hydrogéologiques, et ceci est valide au-delà des seules surfaces d'ordre 1. Il en est de même pour les conditions des régions nordiques, avec une dominante de sols forestiers tourbeux et aménagés. On a observé que le volume de neige fondue affectait bien la fraction d'écoulement direct, mais la variabilité est considérable. Environ la moitié de cette variabilité de la part d'écoulement direct est expliquée par l'écoulement maximal de saison de fonte et le pourcentage de sols organiques. Cette variabilité croît aussi avec la diversité des types de terrains tourbeux. Il est supposé que la rétention de surface et les zones saturées jouent, dans les tourbières, un rôle majeur pour expliquer la part de l'écoulement direct dans la contribution aux hautes eaux des rivières.

Les conditions géomorphologiques locales, géologiques et climatiques peuvent avoir un impact majeur sur l'écoulement direct. Par conséquent, des tentatives de généralisation devraient être conduites sur des secteurs géomorphologiques et géologiques délimités, par exemple la Scandinavie, l'Europe centrale, l'Australie, le nord des Etats-Unis/Canada, ... , en prenant en compte les conditions locales. A l'avenir, de plus gros efforts devraient aussi être consacrés à l'exploitation des informations sur les processus issues des analyses isotopiques, pour les modélisations hydrologiques et hydrochimiques aux échelles des bassins et des régions, et pour l'estimation des impacts des changements environnementaux.

L'incorporation des connaissances concernant les liens entre la dynamique de génération des écoulements (par exemple l'extension de la surface contributive) et les autres processus dynamiques,

tels que l'activité biologique, pourrait améliorer l'exactitude et la précision des estimations des exportations de nutriments, et devrait être utilisée de façon croissante dans les modèles.

Régimes agricoles. Les pertes en substances nutritives des sols agricoles ont un impact fort sur la composition de l'eau courante. Le temps de séjour de la nappe superficielle du bassin de l'Hupselse, aux Pays Bas, varie de quelque(s) mois à 5 ans. Environ 60% de l'écoulement en rivière annuel est constitué par l'eau de la nappe superficielle, et détermine près de 80% de la charge annuelle en azote de la rivière. L'écoulement superficiel et subsuperficiel, qui représentent seulement 5% de l'écoulement annuel, contribuent pour presque 40% de la charge annuelle en phosphore.

La méthode de bilan d'énergie nouvellement redéveloppée, pour l'évaluation de l'évapotranspiration potentielle, peut être utilisée pour générer des données d'entrée dans le modèle SWAP93. Les résultats de la simulation ont été comparés avec la quantité d'eau réellement extraite du sol par la zone racinaire de la végétation, et avec le volume d'eau percolé en aval de la zone racinaire obtenu par bilan hydrogéologique. Le modèle SWAP93, testé dans les conditions du Mont Sumava, semble être utilisable pour l'estimation des diverses composantes du bilan de l'eau.

Les conclusions de la quatrième partie, sur la modélisation des écoulements en condition de données rares, sont relativement encourageantes. Si la modélisation fine des processus y est vouée à l'échec, il semble exister des niveaux globaux qui soient pertinents et déjà intéressants, au moins pour l'estimation régionale de la ressource en eau.

References of chapter 6

Références bibliographiques du chapitre 6

- Andersson L., Sundblad K. (1992): Relations between hydrological parameters and concentrations of nitrogen in the stream discharge from small forested catchments - a case study from the Däntersta catchment. In: M. Lundteigen Fossdal (ed.), Proc. Workshop for Nordic Hydrological Programme at Kaerbaekminde, Denmark, 21-23 December, 1991. Norwegian National Committee for Hydrology, Oslo, Rep. no. 29, pp 159-170.
- Arheimer B., Wittgren H.B. (1994): Modelling the effects of wetlands on regional nitrogen transport. *Ambio*, 23:378-386.
- Arheimer B., Andersson L., Lepistö A. (1996): Variation of nitrogen concentration in forest streams - influences of flow, seasonality and catchment characteristics. *Journal of Hydrology* 179: 281-304.
- Belmans C., Wesseling J.G., Feddes R.A. (1983): Simulation model of the water balance of a cropped soil: SWATRE. *J. Hydrol.*, 63, 271-286.
- Bengtsson L., Lepistö A., Saxena R.K., Seuna P. (1991): Mixing of meltwater and groundwater in a forested basin. *Aqua Fennica* 21: 3-12.
- Bengtsson L., Seuna P., Lepistö A., Saxena R.K. (1992): Particle movement of melt water in a subdrained agricultural basin. *J. Hydrol.* 135: 383-398.
- Betson R.P. (1964): What is watershed runoff? *J. Geophys. Res.* 69:1541-1552.
- Beven K.J., Kirkby M.J. (1979): A physically based variable contributing area of basin hydrology. *Hydrol.Sci. Bull.*, 24, 43-69
- Beven K., Lamb R., Quinn P., Romanowicz R., Freer J. (1995): TOPMODEL. In: Singh, V.P. (ed.) Computer models of watershed hydrology. Water Resources Publications, Littleton, Colorado. 1144 p.
- Bishop K.H. (1991): Episodic increases in stream acidity, catchment flow pathways and hydrograph separation. University of Cambridge, Dept. of Geography. Cambridge. PhD thesis. 246 p.
- Blazkova S., Beven K.J. (1995): Frequency version of TOPMODEL as a tool for assessing the impact of climate variability on flow sources and flood peaks. (in Czech) *J. Hydrol. Hydromech.*, 43, 6, 392-411
- Blazkova S., Kulasova A. (1995): TOPMODEL and terrain survey. (in Czech), Project GA/2533/94, Report 95, p. 16-32
- Bonell M. (1993): Progress in the understanding of runoff generation dynamics in forests. *J. Hydrol.* 150: 217-275.
- Broek van den B.J., Elbers J.A., Huygen J., Kabat P., Wesseling J.G., Dam van J.C., Feddes R.A. (1994): SWAP 1993: Input instructions manual. DLO - Staring Centrum, Wageningen, Internal Note 291, The Netherlands.
- Bubenickova L., Hancvencl R. (1990): Infiltration tests in the Black Desna basin - July 1989. (in Czech), CHMI Research Project 155/02, 1-90
- Buchtele J., Buchtelova M., Fortova M.(1995): Possible changes of flood flows due to climate warming (as simulated by the rainfall-runoff model). Proc. Regional Workshop on Climate Variability and Climate Change Vulnerability and Adaptation, Prague, Czech Republic.
- Buchtele J., Elias V., Tesar M., Herrmann A. (1996): Runoff components simulated by rainfall - runoff models. *Hydrol.Sci. J.* 41, 1996, 49-59.
- Burnash J.C.R., Ferral R.L., McGuire R.A. (1973): Generalized streamflow simulation system. NWS and California Dept. of Water Res., Technical Report, California, USA
- Burt T.P., Arkell B.P., Trudgill S.T., Walling D.E. (1988): Stream nitrate levels in a small catchment in south west England over a period of 15 years (1970-85). *Hydrol. Process.*, 2:267-284.
- Buttle J.M. (1994): Isotope hydrograph separations and rapid delivery of pre-event water from drainage basins. *Progress in Physical Geography* 18: 16-41.
- Christophersen N, Kjaerensrod S, Rodhe A (1984): Preliminary evaluation of flow patterns in the Birkenes catchment using natural ¹⁸O as a tracer. In: Johansson I. (ed.) Hydrological and hydrogeochemical mechanisms and model approaches to the acidification of ecological systems. IHP workshop, Uppsala, Sept. 1984. Nordic Hydrological Programme, No. 10: 29-40.
- Dezetter A. (1991): Modélisation globale de la relation pluie débit. Application en zone de savanes soudanaises (Nord-Ouest de la Côte d'Ivoire). Thèse de Doctorat. Université Montpellier II.
- Dillon P.J., Molot L.A. (1990): The role of ammonium and nitrate retention in the acidification of lakes and forested catchments. *Biogeochemistry*, 11:23-43.

- Driscoll, C.T., Shaefer, D.A., Molot, L.A., Dillon, P.J. (1989): Summary of North American data. In: J.L. Malanchuk and J. Nilsson (Editors), *The Role of Nitrogen in the Acidification of Soil and Surface Waters*, Nordic Council of Ministers, Copenhagen, Environmental Report 1989:10, pp. 7.1-7.4.
- Dunne T., Black R.D. (1970): Partial area contributions to storm runoff in a small New England watershed. *Water Resour. Res.* 6: 1296-1311.
- Edijatno M.C. (1989): Un modèle pluie-débit journalier à trois paramètres. *La Houille Blanche*, n°2: 113-121.
- Eertwegh G.A.P.H. van den (1996): Water- en nutriëntenhuishouding stroomgebied Hupselse beek. R.I.V.M. rapport 714901005 (in Dutch).
- Eertwegh G.A.P.H. van den (1997): Nitrogen and phosphorus loads to surface water systems. PhD thesis Wageningen Agricultural University (in prep.).
- Eshleman K.N., Pollard J.S., Kuebler O'Brien A. (1993): Determination of contributing areas for saturation overland flow from chemical hydrograph separations. *Water Resour. Res.* 29: 3577-3587.
- Federer C.A. (1993): BROOK 90 - A simulation model for evapotranspiration, soil water and streamflow. USDA Forest Service, Durham.
- Feddes R.A., Koopmans R.W.R., Dam J.C. van (1996): *Agrohydrology*. Wageningen Agricultural University, Dept. Of Water Resources.
- Fritz P., Fontes J.C. (eds.) (1980): *Handbook of Environmental Isotope Geochemistry*, vol. 1: The Terrestrial Environment, A. Elsevier, 545 pp.
- Gee G.W., Kincaid C.T., Lenhard R.J., Simmons C.S. (1991): Recent studies of flow and transport in the vadose zone. *Reviews of Geophysics* 29, Supplement. U.S. National report to International Union of Geodesy and Geophysics 1987-1990, p. 227-239.
- Genuchten M.Th. van, Nielsen D.R. (1985): On describing and predicting the hydraulic properties of unsaturated soils. *Annales Geophysicae* 3(5), 615-628.
- Genuchten M.Th. van, Leij F.J. (1992): On estimating the hydraulic properties of unsaturated soils. In: M.Th. van Genuchten, F.J. Leij, and L.J. Lund (ed.), *Indirect methods for estimating the hydraulic properties of unsaturated soils*. Proceedings of the international workshop, Riverside, California, U.S.A., October 11-13, 1989. U.S. Salinity Laboratory, ARS, U.S. Dept. of Agriculture and Dept. of Soil and Environmental Sciences, Univ. California, Riverside, California, U.S.A., p. 1-14.
- Glass R.J., Parlange J.-Y., Steenhuis T.S. (1991): Immiscible displacement in porous media: stability analysis of three-dimensional, axisymmetric disturbances with application to gravity-driven wetting front instability. *Water Resour. Res.* 27:1947-1956.
- Glass R.J., Nicholl M.J. (1996): Physics of gravity fingering of immiscible fluids within porous media: an overview of current understanding and selected complicating factors. *Geoderma* 70:133-163.
- Guilbot A. (1986): Des multiples applications d'un modèle conceptuel du cycle de l'eau en France. *Revue Internationale des Sciences de l'eau*, Vol 2-1: 19-26.
- Haldorsen S. (ed.) (1990): Hydrogeological properties of Nordic tills. The Nordic Coordinating Committee for Hydrology (KOHYNO), Oslo. NHP Report 25. 250 p.
- Helsel D.R., Hirsch R.M. (1992): *Statistical methods in water resources*. Studies in Environmental Science No. 49. Elsevier, Amsterdam. 522 p.
- Herrmann A. (1993): The application of isotopic tracer techniques for hydrological process studies. In: Robinson, M. (ed.) *Flow Regimes from International Experimental and Network Data (FRIEND)*, Volume III: Inventory of streamflow generation studies. Institute of Hydrology, Wallingford. p. 17-34.
- Herrmann A. (1994): Ecohydrological research on a small catchment scale: scientific approach of the runoff formation key process. *Beiträge zur Hydrologie der Schweiz* 35, 83-95.
- Hewlett J.D., Hibbert A.R. (1967): Factors affecting the response of small watersheds to precipitation in humid areas. In: Sopper, W.E. & Lull, H.W. (eds.) *International symposium on forest hydrology*. Pergamon Press, New York. p. 275-290.
- Hillel D. (1987): Unstable flow in layered soils: a review. *Hydrological Processes* 1:143-Raats, P.A.C. 1973. Unstable wetting fronts in uniform and non-uniform soils. *Soil Sci. Soc. Am. Proc.* 37:681-685.
- Holko L. (1995): Stable environmental isotopes of ^{18}O and ^2H in hydrological research of mountainous catchment. *J. Hydrol. Hydromech.*, 43(4-5): 249-274
- Holko L., Kostka Z., Buchtele J., Lepistö A. (1996): Runoff modelling in a mountain catchment. *Ecological Processes in Small Basins*, Conf. and 6th Gen. Assembly of ERB, Strasbourg, France
- Holko L., Lepistö A. (1997): Modelling the hydrological behaviour of a mountainous catchment using TOPMODEL. *J. Hydrol.* (in press)

- Hooper R.P., Shoemaker C.A. (1986): A comparison of chemical and isotopic hydrograph separation. *Water Resour. Res.* 22: 1444-1454.
- Jacks G., Olofsson E., Werme G. (1986): An acid surge in a well-buffered stream. *Ambio* 15: 282-285.
- Jong R. de, Kabat P. (1990): Modelling Water Balance and Grass Production. *Soil Sci. Soc. Am. J.* 54, 1725-1732.
- Kliner K., Knezek M. (1974): The underground runoff separation method making use of the observation groundwater table. *J. Hydrol. Hydromech.* 22(5): 457-466 (in Czech with English abstract).
- Kostka Z. (1995): Soil moisture spatial variability in mountain catchment and role of forest as hydrological factor. *J. Hydrol. Hydromech.*, 43, 4-5, 301-318
- Kouamé B. (1992): Adéquation de différents modèles globaux pluie-débit pour déterminer les apports en eau dans les zones de transition et de forêt de la Côte d'Ivoire. Essai de régionalisation des paramètres. Thèse de Doctorat. Université Montpellier II.
- Kuusisto E. (1984): Snow accumulation and snowmelt in Finland. National Board of Waters, Helsinki. Publications of the Water Research Institute 55. 149 p.
- Lepistö A. (1994): Areas contributing to generation of runoff and nitrate leaching as estimated by empirical isotope methods and TOPMODEL. *Aqua Fennica* 24: 103-120.
- Lepistö A. (1995): Runoff generation processes in peaty forest catchments - possibilities for regionalization. In: Leibundgut, Ch. (ed.) Tracer technologies for hydrological systems. Proceedings of the Boulder Symposium, July 1995. IAHS Press, Wallingford. IAHS Publ. No. 229: 285-294.
- Lepistö A. (1996): Hydrological processes contributing to nitrogen leaching from forested catchments in Nordic conditions. Monographs of the Boreal Environment Research. 72 p. Ph.D. Thesis.
- Lepistö A., Seuna P. (1990): Hydrological characteristics affecting the runoff water acidity. In: Kauppi, P., Kenttämies, K. & Anttila, P. (eds.) Acidification in Finland. Springer-Verlag, Berlin. p. 825-847.
- Lepistö A., Andersson L., Arheimer B., Sundblad K. (1995): Influences of catchment characteristics, forestry activities and deposition on nitrogen export from small forested catchments. *Water, Air and Soil Pollut.* 84:81-102.
- Löfgren S. (ed.) (1991): Influence of atmospheric nitrogen deposition on nitrogen leakage to surface water in forest ecosystems. Nordic Council of Ministers, Copenhagen, Nord32, 52 p.
- Lowrance R.R., Leonard R., Sheridan J. (1985): Managing riparian ecosystems to control nonpoint pollution. *Journal of Soil Water Conservation* 40:87-91.
- Lundin L. (1990): Saturated hydraulic conductivity of Nordic till soils. In: Haldorsen, S. (ed.) Hydrogeological properties of Nordic tills. The Nordic Coordinating Committee for Hydrology (KOHYNO), Oslo. NHP Report 25: 51-55.
- Makkink G.F. (1960): Testing the Penman formula by means of lysimeters. *Journal of the Institution of Water Engineers* 11 (1957), pp. 277-288.
- Moldan B., Cerný J. (1994): Biogeochemistry of Small Catchments. A Tool for Environmental Research. Wiley, 419 pp.
- Moore I.D., Grayson R.B., Ladson A.R. (1991): Digital terrain modelling: a review of hydrological, geomorphological, and biological applications. *Hydrological Processes* 5: 3-30.
- Moser H., Rauert W. (eds.) (1980): Isotopenmethoden in der Hydrologie. Gebr. Borntraeger, 400 pp.
- Oerter H., Rauert W., Stichler W. (1980): Untersuchungen zum Abfluß eines Alpengletschers (Vernagtferner/Ötztaler Alpen) bei unterschiedlichen Ablationsbedingungen mittels Umweltisotopen. Proc. Aix-les-Bains 16ème Congr. Int. Météorol. Alpine, 285-290.
- Paturel J.E., Servat E., Vassiliadis, A. (1995): Sensitivity of conceptual rainfall-runoff algorithms to errors on input data. Case of the GR2M model. *J. Hydrol.*, 168: 111-125.
- Plymale A.E., Boerner R.E.J., Logan T.J. (1987): Relative nitrogen mineralization and nitrification in soils of two contrasting hardwood forests: Effects of site microclimate and initial soil chemistry. *For. Ecol. Manage.*, 21:21-36.
- Prazak J., Sir M., Kubik F., Tywoniak J., Zarcone C. (1992): Oscillation phenomena in gravity driven drainage in coarse porous media. *Water Resour. Res.*, 28, 1849-1855.
- Prazak J., Sir M., Tesar M. (1994): Estimation of plant transpiration from meteorological data under conditions of sufficient soil moisture. *J. Hydrol.*, 162, 409-427.
- Prazak J., Sir M., Tesar M. (1996): Parameters determining plant transpiration under conditions of sufficient soil moisture. *J. Hydrol.*, 183, 425-431.
- Ritsema C.J., Dekker L.W., Hendrickx J.M.H., Hamminga W. (1993): Preferential flow mechanism in a water repellent sandy soil. *Water Resour. Res.* 29:2183-2193.

- Roberts, G., Hudson J.A., Blackie J.R. (1984): Nutrient inputs and outputs in a forested and grassland catchment at Plynlimon, Mid Wales. *Agricultural Water Management* 9:177-191.
- Rodhe A. (1987): The origin of streamwater traced by oxygen-18. Uppsala University, Dept. Physical Geography, Div. Hydrology, Uppsala. Report Series A, No. 41. 260 p.
- Rooij G.H. de (1995): A three-region analytical model of solute leaching in a soil with a water-repellent top layer. *Water Resour. Res.* 31:2701-2707.
- Rooij G.H. de (1996): Preferential flow in water-repellent sandy soils - Model development and lysimeter experiments. Doctoral thesis, Wageningen Agricultural University, The Netherlands. 229 pp.
- Rooij G.H. de, Vries P. de (1996): Solute leaching in a sandy soil with a water-repellent surface layer: a simulation. *Geoderma* 70:253-263.
- Rooij G.H. de, Warrick A.W., Gielen J.L.W. (1996): Steady flow from a disc source above a shallow water table. *J. Hydrol.* 176:37-55.
- Servat E., Dezetter A. (1991): Selection of calibration objective functions in the context of rainfall-runoff modelling in a sudanese savannah area. *Hydrological Sciences Journal*, 36,4.
- Servat E., Dezetter A. (1993): Rainfall-runoff modelling and water resources assessment in north western Ivory Coast. Tentative extension to ungauged catchments. *J. Hydrol.*, 148 (1993): 231-248.
- Seuna P. (1988): Effects of clear-cutting and forestry drainage on runoff in the Nurmes-study. In: Symposium on the hydrology of wetlands in temperate and cold regions, Vol. 1. The Academy of Finland, Helsinki. Publications of the Academy of Finland 4/88: 122-134.
- Sir M., Vogel T., Cislérova M. (1985): The analytical expression of the retention curves and hydraulic conductivities. (In Czech). *J. Hydrol. Hydromech.*, 33 (1), 74-85.
- Sir M., Kutilek M., Kuraz V., Krejca M., Kubik F. (1988): Field estimation of the soil hydraulic characteristics. *Soil Technol.*, 1, 63-75.
- Sir M., Kubik F., Tesar M., Prazak J. (1996a): Liquid transport in porous media. Part I. Theory of aggregation. *J. Hydrol. Hydromech.*, 44, Vol. 2-3, 81-90.
- Sir M., Kubik F., Tesar M., Prazak J. (1996b): Liquid transport in porous media. Part II. Examples. *J. Hydrol. Hydromech.*, 44, Vol. 4, 235-251.
- Sklash M.G. (1990): Environmental isotope studies of storm and snowmelt runoff generation. In: Anderson, M.G. & Burt, T.P. (eds.) *Process studies in hillslope hydrology*. John Wiley & Sons, Chichester. P. 401-435.
- Smith R.E., Hebbert R.H.B. (1983): Mathematical simulation of interdependent surface and subsurface hydrologic processes. *Water Resour. Res.* 19: 987-1001.
- Snyder W.M. (1963): A water yield model derived from monthly runoff data. *International Association of Scientific Hydrology Publication n° 63*, 18-30.
- Starr J.L., Parlange J.-Y., Frink C.R. (1986): Water and chloride movement through a layered field soil. *Soil Sci. Soc. Am. J.* 50:1384-1390.
- Stichler W., Herrmann A. (1982): Environmental isotopes as tracers in water balance studies of mountainous watersheds. In: Berne Symp. on Hydrological Research Basins, vol. 2, 357-368.
- Stichler W., Herrmann A. (1985): Application of environmental isotope techniques in water balance studies of small basins. *IAHS Publ. no. 148*, 93-112.
- Sverdrup H., Warfvinge P., Jonsson C. (1994): Critical loads of acidity for forest soils, groundwater and first-order streams in Sweden. In: Hornung, M., Skeffington, R.A. (eds.): *Critical loads: concept and applications*. ITE symposium no. 28, 1992, ITE, 54-67
- Swanson F.J., Gregory S.V., Sedell J.R., Campbell A.G. (1982): Land-water interactions in the riparian zone. In: Edmonds, R.L. (ed) *Analysis of coniferous forest ecosystems in the Western United States*. Hutchinson & Ross Publishing Co., Stroudsburg, Pennsylvania. *US/IBP Synthesis Series* 14:267-291.
- Tesar M., Buchtele J., Sir M. (1994): Influence of the effect of deforestation on the formation of runoff from the watershed. In: *Proceedings of the International Conference Developments in Hydrology Mountainous Areas*. Stara Lesna, Slovakia, 83 - 84.
- Tesar M. (1996): *Experimental Basis and Catchments in the Sumava Mts. (Czech Republic)*. ERB Newsletter.
- Turner J.W., Macpherson D.K. (1990): Mechanisms affecting streamflows and streamwater quality: An approach via stable isotope, hydrogeochemical and time series analysis. *Water Resour. Res.*, 26:3005-3019.
- Verry E.S., Boelter D.H. (1978): Peatland hydrology. In: Greeson, P.E., Clark, J.R. & Clark, J.E. (eds.) *Wetland functions and values: The state of our understanding*. American Water Resources Association, Minneapolis. p. 389-402.

- Vilimec J. (1995): Preliminary results of modelling by chemical model PROFILE on the basin Uhlirska. (in Czech), Project GA/1533/95, Report 95, 33-44
- Vitousek P.M., Gosz J.R., Grier C.C., Melillo J.M., Reiners W.A., Todd R.L. (1979): Nitrate losses from disturbed ecosystems. *Science* 204: 469-474.
- Wesseling J.G., Kabat P., Broek B.J. van den, Feddes R. A. (1989): Simulation model of the water balance of a cropped soil with different types of boundary condition including the possibility of drainage and irrigation and the calculation of crop yield. Instruction for input to SWACROP. Winand Staring Centre, Wageningen, The Netherlands.
- Wheater H.S., Langan S.J., Brown A., Beck M.B. (1991): Hydrological response of the Allt a'Mharcaidh catchment - inferences from experimental plots. *J. Hydrol.* 123: 163-199.
- Whitehead P.G., Neal C., Neale R. (1986): Modelling the effects of hydrological changes on stream water acidity. *J. Hydrol.* 84: 353-364.
- Whitehead P.G., Robinson M. (1993): Experimental basin studies - an international and historical perspective of forest impacts. *J. Hydrol.* 145: 217-230.
- Zuber A. (1986): Mathematical models for the interpretation of environmental radioisotopes in groundwater systems. In: Fritz P., Fontes J.C. (eds.) (1980): *Handbook of Environmental Isotope Geochemistry*, vol. 1: The Terrestrial Environment, A. Elsevier, 1-59.
- Zuber A., Maloszewski P., Stichler W., Herrmann A. (1986): Tracer relations in variable flow. In: *Proc. Athens Symp. on Underground Water Tracing (SUWT)*, Inst. Geol. Min. Explor. Athens, 355-360.

Chapter 7

Long series : models and trends

Brève introduction

A. Afouda

L'hydrologie, telle qu'elle s'est imposée dans la pratique quotidienne au niveau mondial, s'appuie en grande partie sur l'utilisation des séries chronologiques. Tout événement hydrologique se repère dans l'espace et dans le temps et cette structure spatio-temporelle, que l'on retrouve pour chaque événement hydrologique, se retrouve dans la série correspondante. Si la distribution spatiale des appareils de mesure varie largement de par le monde et dépend du niveau de développement des pays, les échelles de temps ont été standardisées au niveau mondial et vont de la minute (pour les intensités de pluies) à l'année (pour les hauteurs de pluies), en passant par les échelles intermédiaires. En respectant ces échelles lors de la constitution des banques de données puis de leur utilisation, l'hydrologue peut espérer retrouver les paramètres invariants d'échelle caractérisant les lois propres des phénomènes hydrologiques et mettre en évidence des "invariants climatiques" propres à chaque entité géographique.

Mais pendant longtemps, ces structures sous-jacentes ont seulement été admises en hypothèse. La stationnarité et l'homogénéité des séries de hauteurs pluviométriques annuelles observables en une station, ainsi que l'indépendance des réalisations successives constituant ces séries, sont admises comme hypothèses de base et des normes de calcul sont orientées à partir de ces hypothèses (Hubert et Carbonnel 1987, Réménieras 1976). Depuis quelques années, les progrès réalisés dans l'instrumentation de mesure, dans les méthodes et les moyens de calcul ainsi que la persistance de certains phénomènes naturels comme la sécheresse du Sahel, ont conduit les hydrologues à s'interroger sur la validité de ces hypothèses. Des études assez fines (Hubert et Carbonnel 1987) ont conduit à la remise en cause de l'hypothèse d'indépendance et, en mettant en évidence la présence de ruptures dans l'ensemble des séries en Afrique soudano-sahélienne, ont abouti à l'abandon de l'hypothèse de stationnarité des séries pour cette région. L'étude des effets d'échelle est remise à l'ordre du jour comme le montre ici l'article de Hubert et Bendjoudi. Ces auteurs proposent, pour traiter le type de variabilité observé pour l'Afrique soudano-sahélienne, des outils et méthodes fractals qui permettent la mise en évidence des paramètres invariants d'échelle. Ils montrent, sur des échelles de temps allant de 8 à 128 jours (de quelques jours à quelques mois), que l'occurrence des pluies présente pour la station de Dédougou au Burkina Faso, une structure autosimilaire dont la dimension fractale est égale à 0.79. Cette structure et sa dimension sont rapprochées de la place qu'occupe la saison des pluies dans l'année en Afrique soudano-sahélienne et qui est d'environ 7 mois sur 12 mois (d'Avril à Octobre). Calculée, non plus sur l'ensemble de la série disponible, mais sur des sous-ensembles secs et humides, cette dimension fractale de l'occurrence de pluie apparaît stable.

L'identification d'une variabilité de la pluviométrie en Afrique non sahéenne a été abordée par Paturel et al. La zone étudiée dans ce cas couvre 16 pays d'Afrique de l'ouest et du centre et concerne une centaine de postes pluviométriques avec des séries chronologiques qui remontent aux années 1920-1930. L'utilisation du test de Pettitt permet, encore dans ce cas, de déceler une rupture dans les séries chronologiques en 1969-1970, pour l'ensemble de la région.

Enfin dans les longues séries disponibles dans la base AMHY, Bendjoudi et Hubert ont rassemblé des séries de précipitations, de débits, de mesures de la piézométrie aussi bien que de la qualité de l'eau et d'autres paramètres hydrologiques. L'extension spatiale des stations considérées couvre les pays du groupe AMHY. Les premiers traitements qui donnent un aperçu de la structure des séries pluviométriques annuelles montrent que la corrélation de la partie commune de ces séries, prises deux à deux, présente une extinction aux alentours de 1500 km.

L'ensemble des chroniques hydrométriques rassemblées, dans la base AMHY illustre remarquablement bien, la diversité des paramètres et la complexité des séries qui devraient être exploitées dans le cadre de l'étude d'une évolution climatique discontinue.

ooooo

Short introduction

A. Afouda

Hydrology as it has taken the lead in everyday life throughout the world, is based for the most part on the use of time series. Any hydrological event is located in space and time. That space-time structure, which is observed in each hydrological event, is recorded in the corresponding series. The space distribution of measuring instruments varies widely throughout the world and depends on the level of development of countries whereas time scales have been standardized at the world level. They range from a minute (in the case of rain intensity) to a year (as regards rainfall), with any intermediate scales. By taking those scales into account while building up data banks and using them, the hydrologist can find scale invariant parameters which characterize the specific laws of hydrological phenomena and can underscore "climatic invariants" particular to each geographical entity.

But for a long time, these subjacent structures have only been considered as hypotheses. The stationarity and homogeneity of annual rainfall series observable in a station together with the independence of successive events which constitute those series, are acknowledged as fundamental hypotheses and calculation norms are oriented from those hypotheses (Hubert and Carbonnel 1987, Réménieras 1976). In the last few years, progress made at the level of measuring instruments, advance in calculation methods and tools as well as the persistence of some natural phenomena like the Sahelian drought, have led hydrologists to reflect on the validity of these hypotheses. Fairly advanced studies (Hubert and Carbonnel 1987) have put in question the independence hypothesis and by showing the presence of disruption in all the series in Sudan-Sahelian Africa, have resulted in dropping the hypothesis of stationarity concerning that region. The scale effects study is put on the agenda again as shown here by the paper of Hubert and Bendjoudi. The authors suggest, for the type of variability observed in Sudan-Sahelian Africa, use of fractal tools and methods that help to underscore scale invariant parameters. They show on time scales ranging from 8 to 128 days (from a few days to a few months) that rain occurrence presents, for the Dedougou station in Burkina Faso, a self-similar structure whose fractal size equals 0.79. This structure and its size are compared with the rainy season position within the year in Sudan-Sahelian Africa and which is about 7 months out of 12 (from April to October). Computed not on the basis of the whole available series but on dry and humid subsets, this fractal size of rain occurrence seems to be stable.

The identification of a rainfall variability in non-Sahelian Africa has been dealt with by Paturel and al. The area studied in this case includes 16 countries of West and Central Africa and encompasses about a hundred pluviometrical stations with time series dating back to the 20s -30s. The use of the test of Pettitt allows, in this case too, detection of a disruption in time series in 1969-1970, with regard to the region as a whole.

Finally, in the long series available in the AMHY database, Bendjoudi and Hubert have collected series of precipitation, stream flow, ground water level as well as water quality and other hydrological parameters. The space extension of the examined stations is linked to AMHY group countries. The

first studies that give a hint of the structure of annual rainfall series show that the common part correlation of the series, taken two by two, present an extinction at a distance of about 1500 km.

All the hydrometrical data collected in the AMHY database illustrate outstandingly well parameters variety and series complexity which should be used in the study of a discontinuous climatic evolution.

Caractéristiques fractales des séries pluviométriques

Fractal Characteristics of Rainfall Time Series

P. Hubert, H. Bendjoudi

Nous nous intéresserons ici à des séries chronologiques de mesures pluviométriques mesurées en un point de l'espace grâce à un pluviomètre ou à un pluviographe. Chaque série est caractérisée par un pas de temps, qui est l'intervalle de temps séparant deux observations. La série chronologique est constituée des hauteurs de pluie précipitées au cours des pas de temps successifs. Si l'on admet l'existence à chaque instant d'une intensité de pluie, la hauteur de pluie attachée à un pas de temps particulier est l'intégrale de l'intensité de la pluie calculée du début à la fin de ce pas de temps. Cette hauteur, exprimée par exemple en mm, divisée par la durée du pas de temps, exprimée par exemple en heures, nous permet d'obtenir, en mm/h, l'intensité de la pluie au cours du pas de temps élémentaire. Quel que soit le pas de temps élémentaire il ne s'agit que d'une intensité moyenne et le détail des variations de l'intensité de la pluie au cours du pas de temps échappe totalement à la mesure. Par contre il est aisé de construire à partir d'une série mesurée selon un certain pas de temps d'autres séries chronologiques selon des pas de temps plus importants en regroupant autant de termes de la série initiale que nécessaire. Ces nouvelles séries simulent ce que seraient des mesures réalisées selon d'autres pas de temps. C'est ainsi que l'on constitue à partir de séries de mesures journalières des séries mensuelles ou annuelles.

On peut aisément constater que de nombreuses statistiques et propriétés des séries pluviométriques dépendent du pas de temps d'observation. C'est le cas des valeurs extrêmes des intensités moyennes, d'autant plus faibles que le pas de temps est plus important, ou de l'asymétrie des distributions, d'autant plus grande que le pas de temps est faible. Cette dépendance à l'échelle de temps conduit à ne pas pouvoir répondre en termes absolus à certaines questions d'apparence anodine. Si l'on s'interroge par exemple sur la durée pendant laquelle il a plu en un lieu donné au cours d'une année donnée, la durée proposée par celui qui dispose de données journalières sera beaucoup plus longue que celle qui le serait par un autre observateur disposant de mesures horaires, car la journée pluvieuse du premier sera constituée pour le second d'heures pluvieuses et d'heures qui ne le sont pas et qu'il ne comptabilisera donc pas.

Pendant longtemps les hydrométéorologues se sont peu préoccupés de ces effets d'échelle. Le plus souvent, ils se sont contentés, en fonction des besoins s'exprimant selon une certaine échelle de temps, de mettre au point des outils ad hoc leur permettant de proposer des solutions aux problèmes pratiques qui leur étaient soumis. C'est ainsi que l'on a vu, dans le domaine des statistiques, fleurir des myriades de distributions, chacune étant spécifique d'une échelle de temps, sa seule justification étant toujours in fine la qualité de son ajustement aux données empiriques. Au cours de ces dernières années, de nouvelles mesures (radar, images satellitaires, pluviographes digitaux) ont donné une image renouvelée de la variabilité de la pluviométrie dans le temps et l'espace et de nouveaux besoins, d'agrégation de données ponctuelles et/ou instantanées ou au contraire de désagrégation de données moyennes, sont apparus qui ont conduit les chercheurs à se préoccuper des effets d'échelle.

Dans la nature la pluie n'est ni horaire, ni journalière ni annuelle. C'est un phénomène se déroulant au cours du temps selon ses lois propres. Maîtriser l'effet d'échelle consistera à retrouver des paramètres invariants d'échelle caractérisant ces lois, à déterminer comment s'organisent les traces que laisse ce phénomène, qui existe indépendamment de toute observation, selon différentes échelles de temps. La figure 1 (d'après Raudkivi, 1979) nous permettra d'illustrer très simplement ce propos. Elle représente, sur un diagramme log-log les records de précipitations enregistrés de par le monde pour différentes durées allant de la minute à deux ans. Ces records ne se distribuent pas au hasard mais

s'organisent très correctement autour d'une droite de pente voisine de 0.5. Bien que purement empirique cette observation nous offre un exemple de loi régissant le fonctionnement de l'atmosphère caractérisée par des paramètres invariants d'échelle qui nous permet de relier les manifestations d'un même phénomène selon différentes échelles de temps. C'est dans cet esprit qu'ont été conçues et développées les approches fractales et multifractales dont nous aborderons maintenant quelques aspects.

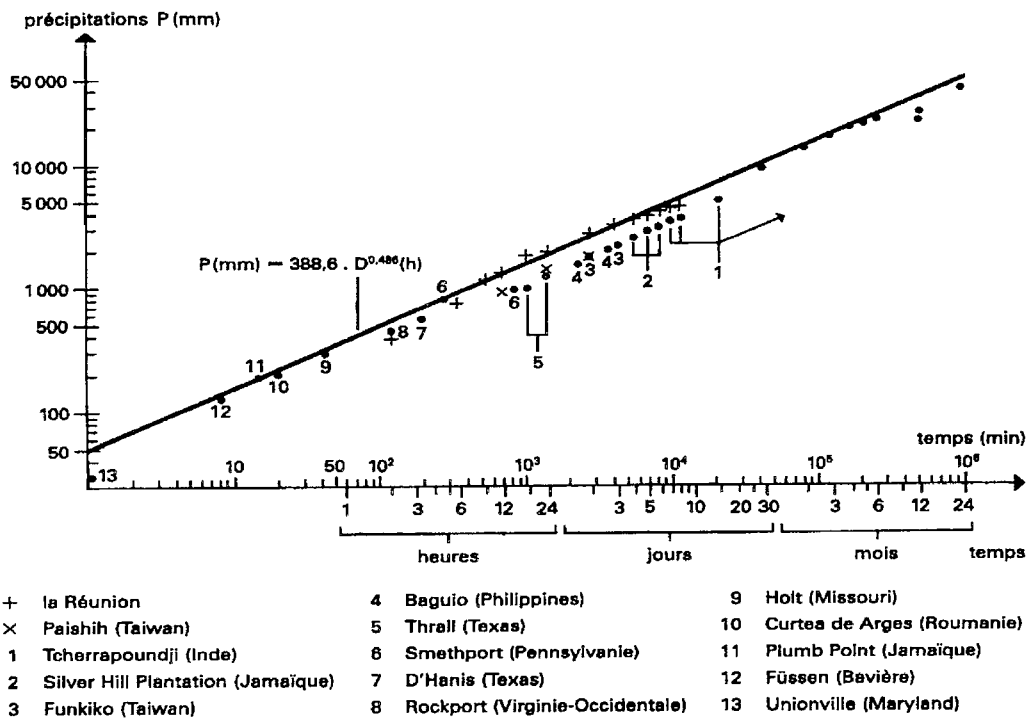

Figure 1 : Records des précipitations de par le monde en fonction de la durée (Raudkivi, 1979)
 Figure 1 : Precipitation records in the world, according to their duration (Raudkivi, 1979)

Les fractals ont d'abord été considérés sous un angle purement géométrique (Mandelbrot, 1975; 1977). Nous avons appliqué une telle approche pour étudier l'intermittence des pluies de la station de Dédougou au Burkina Faso (Hubert et Carbonnel, 1989) à partir de 45 ans de mesures journalières (16284 jours commençant le 1er janvier 1922). L'intermittence exprime le fait que l'on peut observer au cours du temps une succession d'états secs et pluvieux. Etats secs et pluvieux doivent être définis ; ils ne peuvent l'être rigoureusement que relativement à une aire (qui sera ici la surface de captation du pluviomètre), à un intervalle de temps (qui sera ici la journée) et à un seuil de précipitations (que nous avons dans un premier temps fixé à 0.1 mm). Une journée sera donc dite pluvieuse si une quantité de pluie supérieure à 0.1 mm a été recueillie dans le pluviomètre, et sèche dans le cas contraire. Sur l'axe du temps l'occurrence de pluie peut alors être représentée par l'ensemble des segments associés aux journées pluvieuses. C'est un objet géométrique discontinu évoquant une poussière de Cantor, objet classique de la géométrie fractale de Mandelbrot. Nous avons estimé la dimension fractale de cette occurrence de pluie grâce à la méthode du comptage de boîtes (Lovejoy et al, 1987). Etant donné un objet de dimension fractale D, inclus dans un espace de dimension euclidienne E, si on réalise un maillage de cet espace en boîtes de côté a (selon la valeur de E=1, 2 ou 3, les boîtes seront des segments, des carrés ou des cubes), le nombre N de boîtes nécessaires pour recouvrir l'objet fractal considéré est une fonction de a telle que :

$$\text{Log}[N(a)] = - D \text{Log}[a]$$

Dans le cas de l'ensemble que nous nous proposons d'étudier, inclus dans un ensemble de dimension 1, les boîtes sont réduites à des segments et la dimension fractale de l'occurrence de pluie sera nécessairement comprise entre 0 et 1. $N(a)$ étant déterminé pour différentes valeurs de a , D sera estimé comme l'opposé de la pente de la régression de N en a tracée sur un diagramme log-log. On trouvera, sur la figure 2, les résultats de cette procédure pour la série de Dédougou. On peut y observer deux alignements de points.

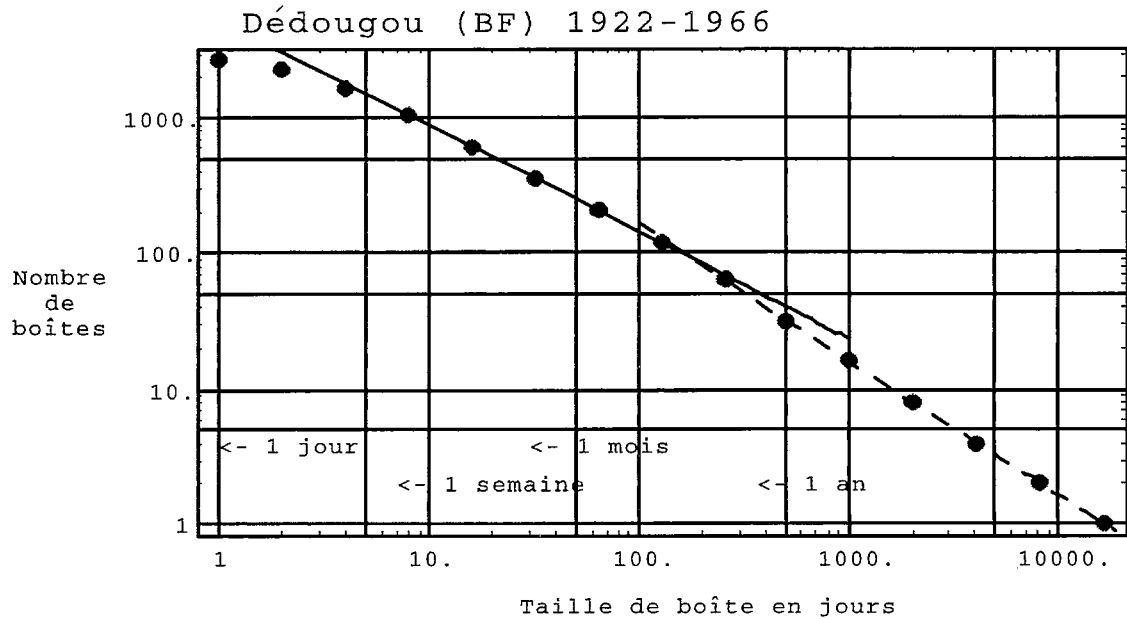

Figure 2 : Résultats de la procédure de comptage des boîtes pour les pluies à Dédougou.
Figure 2 : Results of the box counting procedure for the rainfalls in Dédougou

L'alignement observé pour les longues durées selon une droite de pente -1 (trait interrompu) est trivial. En effet, pour une échelle de temps assez longue (ici au delà de 256 jours), tout intervalle de temps est considéré comme pluvieux puisqu'on y a observé au moins une journée pluvieuse. L'occurrence de pluie se confond alors avec l'axe du temps et sa dimension fractale est égale à 1.

L'autre alignement (trait plein), observé pour des échelles de temps allant de 8 à 128 jours (de quelques jours à quelques mois), selon une droite de pente -0.79, est plus intéressant car il confère à l'occurrence de pluie, sur cette plage d'échelles de temps, une structure autosimilaire dont la dimension fractale est égale à 0.79. Cette structure et sa dimension peuvent être rapprochées de la place qu'occupe la saison des pluies dans l'année en Afrique soudano-sahélienne soit environ 7 mois (d'Avril à Octobre) sur 12. Une poussière de Cantor ayant un tel générateur (Mandelbrot, 1975) aurait une dimension fractale égale à $\text{Log}7/\text{Log}12$ soit 0.783, valeur très proche de celle que nous avons déterminée empiriquement.

La région soudano-sahélienne a connu au cours de ce siècle une succession de phases sèches et humides (Hubert et al, 1989). Calculée non plus sur l'ensemble de la série disponible, mais sur des sous-ensembles secs ou humides, la dimension fractale de l'occurrence de pluie apparaît cependant remarquablement stable (Tableau I).

Tableau 1 : Dimension fractale de l'occurrence de pluie à Dédougou**Table 1 : Fractal dimension of the rainfall occurrence in Dédougou**

Début de la séquence de 4096 jours	Nature de la période	Dimension fractale de l'occurrence de la pluie
01/01/1924	Humide	0.77
01/01/1937	Sèche	0.78
01/01/1953	Humide	0.78
01/01/1969	Sèche	0.77

La géométrie fractale nous fournit donc encore ici un paramètre invariant d'échelle caractéristique de la série pluviométrique dans son ensemble, au delà même des aléas climatiques, et ceci sur une gamme d'échelle de temps allant de quelque jours à quelques mois.

Ces résultats ne doivent cependant pas nous faire oublier qu'un phénomène complexe tel que la précipitation ne se résume pas à occurrence ou non occurrence et qu'il conviendrait de se préoccuper de la notion d'intensité de la pluie selon l'échelle de temps considérée. Cette notion est d'ailleurs implicitement présente dans la définition du seuil de référence définissant l'occurrence de pluie et on peut remarquer (Hubert et al, 1995) que la dimension fractale de l'occurrence de pluie est une fonction décroissante du seuil de référence (pour un seuil de l'ordre de 50 mm elle n'est plus que de l'ordre de 0.1). Cette dépendance de la dimension d'un ensemble à la valeur de son seuil de référence, déjà notée par Schertzer et Lovejoy (1984) ou par Halsey et al (1986), amène à rejeter en pratique dans ce type d'étude la notion d'objet fractal au profit de celle de champ multifractal.

L'approche multifractale vise à relier échelle et intensité pour des processus en cascade concentrant la matière et/ou l'énergie dans des domaines spatio-temporels de plus en plus ténus (Lovejoy et Schertzer, 1986). Les modèles que nous évoquerons ici ont d'abord été conçus comme des modèles phénoménologiques de la turbulence, spécifiquement construits pour reproduire les principales propriétés des équations de Navier et Stokes (invariance d'échelle, conservation d'un flux et dynamique locale). Ces propriétés devraient se retrouver dans les équations encore inconnues régissant d'autres phénomènes atmosphériques et en particulier les précipitations (Schertzer et Lovejoy, 1987a).

Dans l'étude des cascades multifractales on distingue soigneusement leurs propriétés nues et leurs propriétés habillées. Les propriétés nues correspondent à la construction d'une cascade jusqu'à une certaine échelle d'homogénéité liée au phénomène. Au contraire les propriétés habillées sont obtenues par intégration à l'échelle d'observation d'une cascade totalement développée. Par définition les observations pluviométriques horaires, journalières et bien sûr annuelles, sont des propriétés habillées puisqu'elles résultent de l'intégration (au cours du temps) de processus se développant jusqu'à une échelle temporelle beaucoup plus fine. Un des résultats les plus significatifs des recherches sur les multifractals concerne la divergence des moments statistiques d'ordre suffisamment élevé, qui peut apparaître dans certains cas de figures (Mandelbrot, 1974; Schertzer et Lovejoy, 1987b). Cette divergence qui trouve sa source dans une "transition de phase multifractale" (Schertzer et Lovejoy, 1991) est équivalente à la chute algébrique (hyperbolique) de la distributions des intensités au delà d'un certain seuil, chute lente qui correspond en fait à une variabilité maximale. Il est remarquable que, selon la théorie, le paramètre qD caractérisant la décroissance algébrique de la probabilité au dépassement d'un seuil soit indépendant de l'échelle d'observation. Nous avons étudié ce qui n'est a priori qu'une conjecture sur la série chronologique de Dédougou déjà étudiée plus haut. On trouvera sur la figure 3, tracées sur un diagramme log-log, les courbes représentant les probabilités empiriques au dépassement d'un seuil (calculées selon la formule de Weibull) en fonction de ce seuil pour trois échelles de temps à savoir jour, mois et année. Dans les trois cas on observe effectivement une cassure sur la courbe et les droites que l'on peut caler sur les points situés au delà de la cassure ont approximativement la même pente (3.77, 3.42 et 3.42 respectivement estimés à partir de 3, 6 et 15

points). L'hypothèse d'une décroissance algébrique des probabilités au dépassement, identique pour une large gamme d'échelles d'observation, ne semble donc pas irrecevable. Ce résultat peut être rapproché de celui d'une étude multifractale sur la série pluviométrique de Nîmes (Ladoy et al, 1993), où la valeur de l'exposant critique qD a été estimée à $qD = 3.0 \pm 0.2$.

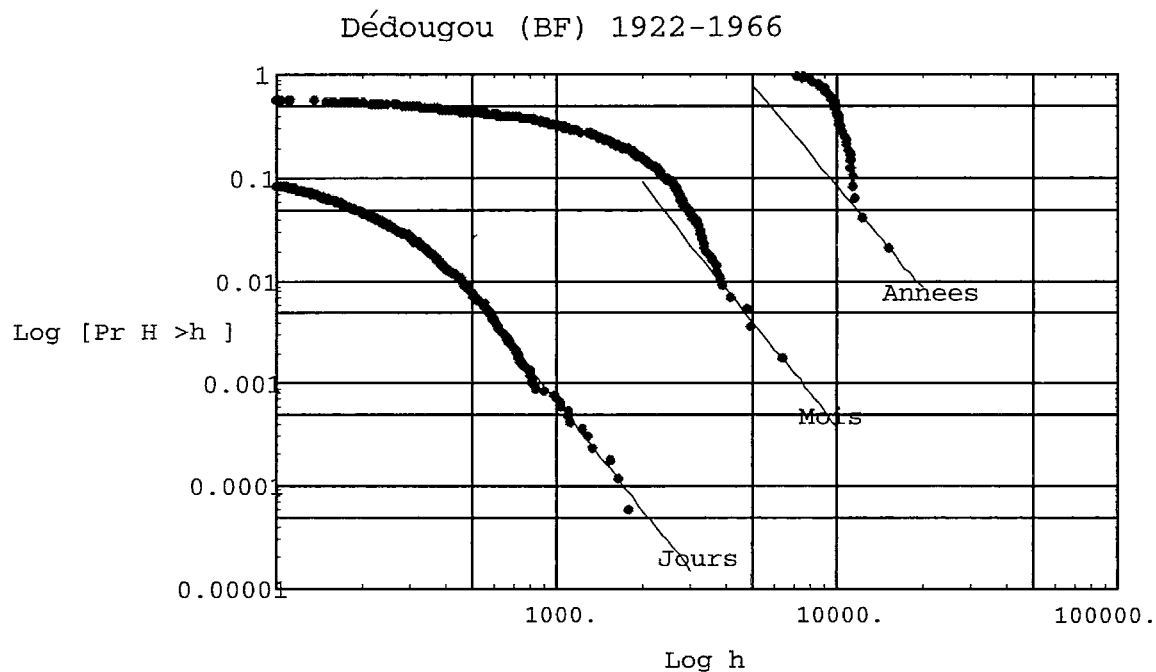

Figure 3 : Probabilités de dépassement d'un seuil en fonction de ce seuil.

Figure 3 : Threshold exceeding probabilities, according to different thresholds

Nous n'avons pu présenter ici qu'une très brève introduction aux méthodes fractales et multifractales et à leur application à l'étude des séries pluviométriques. Nous espérons cependant avoir fait sentir au lecteur que l'invariance d'échelle n'est pas une inaccessible pierre philosophale, mais qu'il s'agit d'un concept qui peut se révéler très fécond. Les conséquences théoriques et pratiques de lois de probabilité à décroissance algébrique sont en particulier considérables, tant en ce qui concerne l'échantillonnage que la prédétermination. Bien sûr il s'agit d'un domaine neuf dont les outils, en particulier en ce qui concerne l'analyse des données, doivent être affinés, mais il ouvre très certainement de nouvelles perspectives à la recherche et à ses applications.

Longues séries pluviométriques en Afrique de l'Ouest et Centrale non sahélienne

Long rainfall series in non Sahelian Western and Central Africa

J.E. Paturel, H. Lubès-Niel, E. Servat, J.M. Fritsch

1 Introduction

Le programme ICCARE (Identification et Conséquences d'une variabilité du Climat en AfRIque de l'ouest non sahélienne) s'inscrit dans le thème 4, intitulé « variabilité climatique », du projet FRIEND-AOC du PHI de l'UNESCO. Il a pour objet l'identification d'une éventuelle fluctuation climatique en Afrique non sahélienne au cours de ces dernières décennies, vers les années 1970. Cette évolution du climat peut se traduire par des changements notables au sein de séries chronologiques pluviométriques.

La sécheresse observée au sahel (Sutcliffe et Knott, 1987; Olivry *et al.*, 1993) depuis 25 ans se fait également ressentir dans les pays plus au Sud qui bordent le Golfe de Guinée. Dans ces régions plus équatoriales et à pluviométrie encore importante, ses conséquences sont moins sévères quoique de nature à pénaliser les projets de développement liés en particulier à l'agriculture, et à nuire au bon fonctionnement d'aménagements (hydroélectriques par exemple) réalisés à partir de données enregistrées lors de périodes pluviométriquement plus favorables (Servat et Sakho, 1993).

La question à laquelle cette étude essaye d'apporter une ou plusieurs réponses est : comment peut-on situer la diminution de la pluviométrie observée depuis 25 ans au sein de la chronologie pluviométrique de ce siècle ?

La zone étudiée couvre 16 pays qui sont, de l'Afrique de l'Ouest vers l'Afrique Centrale, le Sénégal, la Gambie, la Guinée Bissau, la Guinée Conakry, la Sierra Leone, le Liberia, le Mali, le Burkina Faso, la Côte d'Ivoire, le Ghana, le Togo, le Bénin, le Nigeria, le Cameroun, le Tchad et la Centrafrique. Nous n'avons, cependant, considéré que la partie non sahélienne de cette zone. Pour ce, l'étude s'est limitée au Sud du 14ème parallèle.

L'identification d'une variabilité de la pluviométrie a été abordée par l'analyse des séries chronologiques de données de pluie annuelle.

2 Données

Un grand nombre de postes pluviométriques a été utilisé pour constituer les séries chronologiques pluviométriques. Les postes choisis relèvent de la gestion des différents services nationaux des pays concernés. La sélection des postes s'est faite selon les critères suivants :

- information pluviométrique la plus longue possible
- pas plus de 3 années consécutives en lacune
- moins de 10% de lacune sur la série totale
- information suffisamment dense sur la zone d'étude

Ces critères ont conduit à choisir une centaine de postes avec des séries chronologiques qui remontent au moins aux années 1920-1930.

3 Cartographie de la variabilité pluviométrique annuelle

Dans un premier temps, nous n'avons retenu que la période 1930-1990 sur laquelle nous avons une information suffisamment dense. Sur chacun des postes, nous avons déterminé un indice pluviométrique défini comme une variable centrée réduite (Nicholson *et al.*, 1988; Servat, 1994) :

$$\frac{(X_i - \bar{X})}{S}$$

avec X_i : pluviométrie de l'année i ,

\bar{X} : pluviométrie moyenne interannuelle sur la période de référence,

S : écart-type de la pluviométrie interannuelle sur la période de référence.

L'indice pluviométrique, ainsi défini, traduit donc un excédent ou un déficit pluviométrique pour l'année considérée par rapport à la période de référence choisie.

Une cartographie de la moyenne par décennie des indices pluviométriques a été dressée (Figure 1). La carte ainsi obtenue présente des zones à déficit ou excédent pluviométrique plus ou moins marqué. On observe :

- durant les décennies 1930 et 1940 (en particulier cette dernière), des zones ponctuellement déficitaires; les valeurs des indices sont, cependant, faibles en valeur absolue,
- durant les décennies 1950 et 1960, des zones excédentaires; ce caractère s'observe d'abord dans le Nord puis se généralise à l'ensemble de la zone d'étude au cours de la décennie suivante,
- durant les 2 dernières décennies, des zones déficitaires; ce caractère s'accroît au cours de la décennie 1980 et est très marqué au Nord du 10ème parallèle et à l'Ouest du 5ème méridien Ouest; les valeurs des indices sont beaucoup plus élevées, en valeur absolue, qu'auparavant.

4 Application d'une méthode statistique de détection de rupture au sein de séries chronologiques pluviométriques

Dans un second temps, nous avons traité les séries pluviométriques dans leur totalité puisque nous disposons pour certaines stations de mesures qui remontaient au siècle dernier (pays anglophones en particulier).

L'étude a été menée par l'application de tests statistiques de détection de rupture en moyenne des séries chronologiques de pluviométrie annuelle. Plusieurs tests ont été utilisés mais nous ne présentons, ici, que les résultats du test de Pettitt (Pettitt, 1979).

4.1 Formulation du test de Pettitt

Le test de Pettitt est non-paramétrique et dérive du test de Mann-Whitney. L'absence d'une rupture dans la série (x_i) de taille N constitue l'hypothèse nulle.

Pettitt définit la variable $U_{t,N}$:

$$U_{t,N} = \sum_{i=1}^t \sum_{j=t+1}^N D_{ij}$$

où $D_{ij} = \text{sgn}(x_i - x_j)$ avec $\text{sgn}(Z) = 1$ si $Z > 0$, 0 si $Z = 0$ et -1 si $Z < 0$

Il propose de tester l'Hypothèse nulle en utilisant la statistique K_N définie par le maximum en valeur absolue de $U_{t,N}$ pour t variant de 1 à $N-1$.

A partir de la théorie des rangs, Pettitt montre que si k désigne la valeur de K_N prise sur la série étudiée, sous l'hypothèse nulle, la probabilité de dépassement de la valeur k est donnée approximativement par :

$$Prob(K_N > k) \approx 2 \exp(-6 k^2 / (N^3 + N^2))$$

Pour un risque α de première espèce donné, si la probabilité de dépassement estimée est inférieure à α , l'hypothèse nulle est rejetée. La série comporte alors une rupture localisée au moment τ où est observé K_N .

4.2 Analyse des résultats

Les résultats du test montrent que dans une grande majorité des cas, une « rupture » (diminution de la pluviométrie annuelle dans ce cas) au sein de la série chronologique s'observe entre 1960 et 1979 avec un niveau de signification qui varie d'un poste à un autre. Dans seulement 5 cas, la rupture a été observée en dehors de cette période (bien souvent autour des années 1940). Il faut noter, également, que pour 6 postes, le test révèle une augmentation de la pluviométrie annuelle.

Le tableau 1 présente la probabilité associée à la statistique du test calculé pour chacun des postes. Un classement qualitatif a été effectué en tenant compte des valeurs de cette probabilité.

Tableau 1 : Probabilité associée au Test de Pettitt - Rupture entre 1960 et 1979

Table 1 : Pettitt-test associated probability - Breaking date of the 1960 and 1979 period

Probabilité associée	Classe	Dénombrement
< 1%	rupture très significative	32
entre 1 et 5%	rupture significative	10
entre 5 et 20%	rupture peu significative	11
> 20%	série homogène	32
< 5%	excédent pluviométrique	6
< 1%	rupture très significative en dehors de la période 1960-1979	5

Les résultats par classe de cette probabilité ont été reportés sur une carte de la région d'étude (Figure 2).

Cette carte confirme les observations faites auparavant : le phénomène de déficit pluviométrique est plus marqué aux alentours des années 1970, en particulier à l'Ouest du 5ème méridien Ouest et au Nord des 8-10èmes parallèles. Ailleurs, ce phénomène est moins accentué.

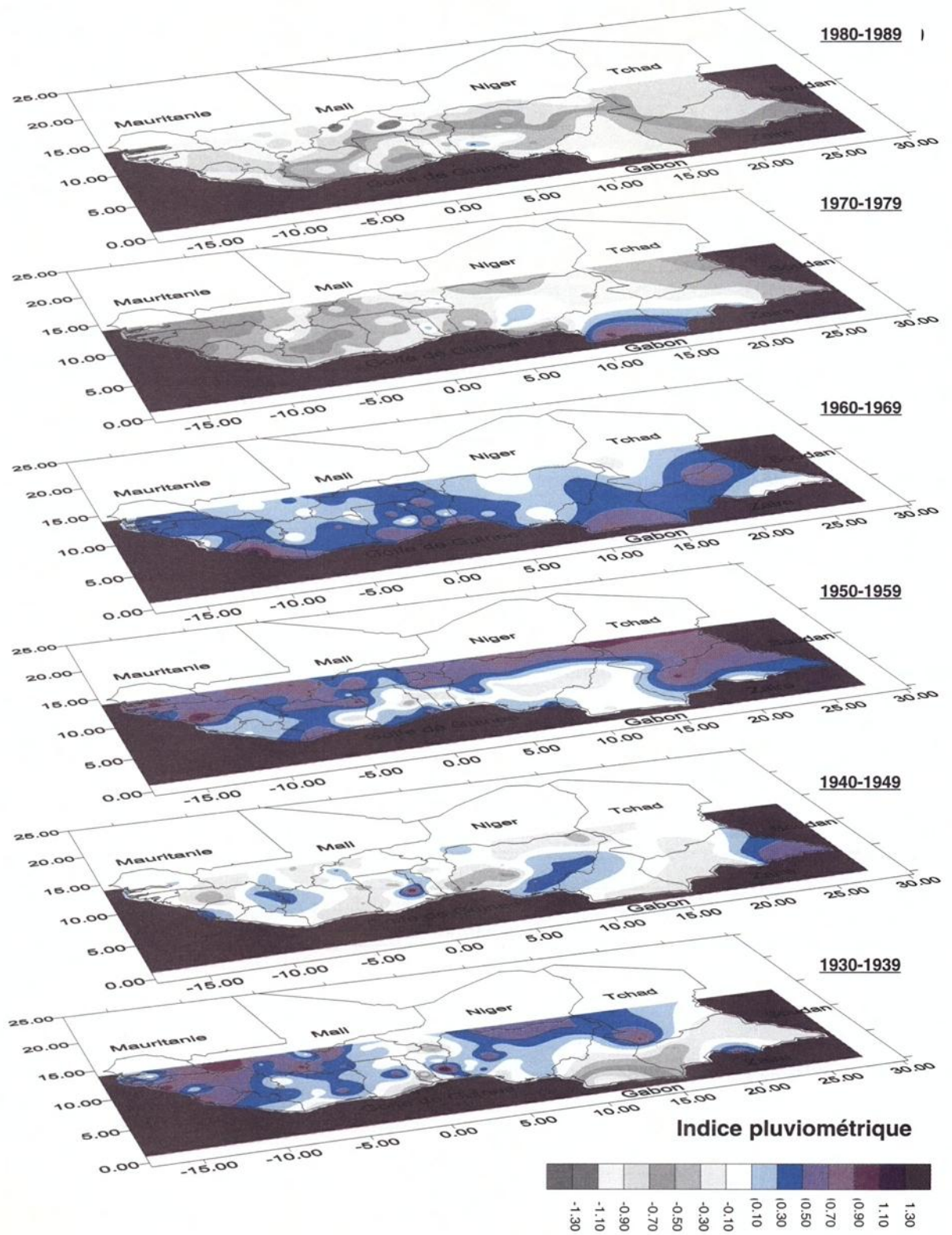

Figure 1 : Indices pluviométriques sur la période 1930-1989
 Figure 1 : Pluviometric rates during the period 1930-1989

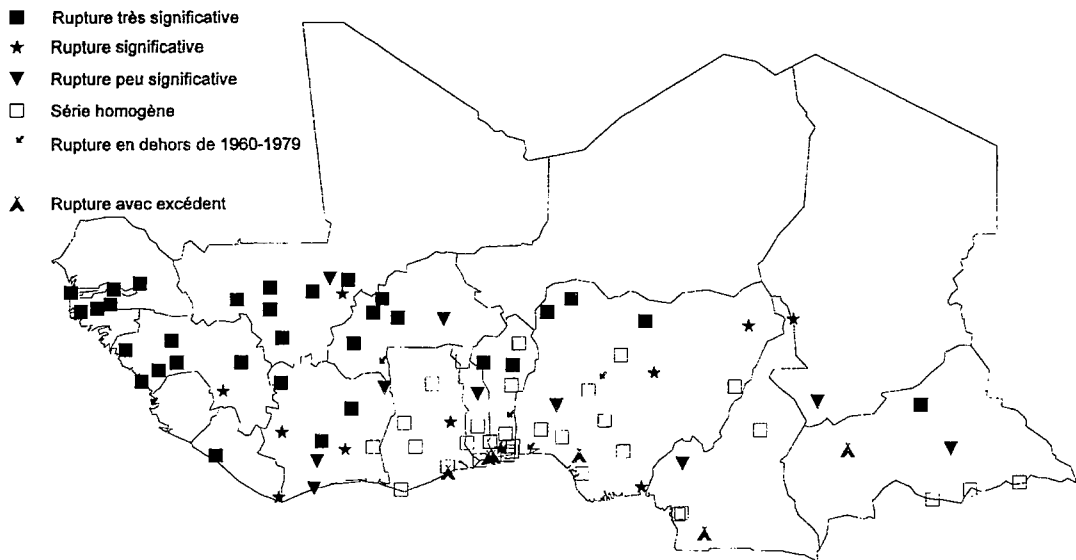

Figure 2 : Niveaux de signification des résultats du Test de Pettitt

Figure 2 : Levels of meaning for the Pettitt Test results

5 Conclusion

Cette étude montre qu'au cours du XX^{ème} siècle, la sous-région a connu une succession de périodes à déficit et de périodes à excédent pluviométrique. Toutefois, autour des années 1970, il y a eu une diminution plus ou moins brutale de la pluviométrie annuelle.

L'étude des séries longues, qui aurait pu masquer ce phénomène en le resituant dans une description plus complète des alternances du climat, confirme bien la réalité et l'importance de cette baisse des précipitations survenue il ya environ 25 ans et toujours d'actualité.

A l'Est de la région étudiée, ce phénomène semble s'inscrire dans l'histoire des « variations naturelles » des séries de cette sous-région sans revêtir le caractère d'exception que l'on observe plus à l'Ouest et au Nord.

Le programme ICCARE s'est efforcé de pouvoir répondre à d'autres interrogations sur les manifestations possibles de cette variabilité de la pluviométrie (Servat *et al.*, 1997; Paturel *et al.*, 1997). Des travaux similaires ont également été menés sur les séries chronologiques débitométriques (Aka *et al.*, 1996) qui confirment une diminution des écoulements.

Remerciements

Les auteurs souhaitent remercier Mme M.O. Delattre et Mr B. Kouamé pour leur très large contribution à cette étude.

Longues séries disponibles dans la base AMHY

Long series available in AMHY database

H. Bendjoudi, P. Hubert

C'est à la réunion annuelle de septembre 1995 du projet UNESCO d'hydrologie régionale, FRIEND-AMHY, que le thème « Longues séries hydrométéorologiques » a été créé.

Ces séries concernent aussi bien les précipitations, les débits ou la piézométrie que la qualité des eaux ou les paramètres météorologiques. Par longues séries il faut entendre une chronique ininterrompue d'une centaine d'années au moins quelque soit son pas de temps (journalier, mensuel ou annuel).

Nous avons donc cherché à rassembler de telles séries et à les mettre en forme dans une base de données conviviale. Après une année cette base a pris forme comme nous allons le voir ci-dessous.

La base de données

La base regroupe actuellement (novembre 1996) 92 séries (tableau 1) :

- 84 stations pluviométriques dont 9 au pas journalier, 51 au pas mensuel et 24 au pas annuel.
- 7 stations hydrométriques dont 3 au pas journalier, 3 au pas mensuel et une au pas annuel.
- une série de taches solaires.

Les dates de début des chroniques s'échelonnent entre 1700 et 1938.

Les dates de fin des chroniques s'échelonnent entre 1915 et 1995.

La série la plus courte est longue de 42 ans et la plus longue atteint 296 ans. La longueur moyenne étant de 119 ans.

On constatera que nous avons dû restreindre nos ambitions initiales (séries de cent ans au moins). Nous y avons été contraints pour tenter de garder une couverture spatiale satisfaisante. Quelques séries « courtes » sont également présentes pour des tests logiciels

Les entrées de la base sont les suivantes :

- Numéro de la série
- Nom de la station de mesure
- Code ISO en deux lettres du pays concerné (AFNOR, 1994)
- Année du début de la série
- Année de fin de la série
- Durée de la série en années
- Nature de la grandeur mesurée :
 - P, précipitation en mm
 - D, débit en m³/s
 - A, autre grandeur

Tableau 1 : liste des stations avec code pays, année de début, année de fin, durée, type et pas de temps**Table 1** : station list, with country code, year of beginning, year of end, duration, type, and time step.

1	Korce	AL	1931	1990	60	P	M	47	Saint-Sever	FR	1880	1993	114	P	M
2	Shkoder	AL	1931	1990	60	P	M	48	Strasbourg	FR	1803	1991	189	P	A
3	Tirane	AL	1931	1990	60	P	M	49	Toulon	FR	1852	1993	142	P	M
4	Salzburg	AT	1881	1993	113	P	M	50	Toulouse	FR	1809	1993	185	P	M
5	Wien	AT	1882	1993	112	P	M	51	Verdon	FR	1874	1915	42	D	A
6	Chiflik	BG	1892	1995	104	P	M	52	Quinson						
7	Ihtyman	BG	1893	1990	98	P	M	53	Gibraltar	GI	1791	1992	202	P	A
8	Pleven	BG	1894	1995	102	P	M	54	Athinai	GR	1871	1990	120	P	J
9	Sadovo	BG	1892	1995	104	P	M	55	Budapest	HU	1841	1994	154	P	M
10	Shipka	BG	1893	1989	97	P	M	56	Debrecen	HU	1854	1994	141	P	M
11	Sliven	BG	1894	1995	102	P	M	57	Kecskemet	HU	1897	1994	98	P	M
12	Bex	CH	1901	1995	95	P	M	58	Keszthely	HU	1871	1994	124	P	M
13	Bourg-Saint-Pierre	CH	1901	1995	95	P	M	59	Sopron	HU	1893	1994	102	P	M
14	Grand-Saint-Bernard	CH	1901	1995	95	P	M	60	Tokaj	HU	1880	1994	115	P	M
15	Lausanne	CH	1901	1995	95	P	M	61	Beer-Sheva	IL	1921	1993	73	P	M
16	Leukerbad	CH	1901	1995	95	P	M	62	Beit Jimal	IL	1919	1993	75	P	M
17	Montreux-Clarens	CH	1901	1995	95	P	M	63	Bra	IT	1862	1991	130	P	J
18	Rhein Basel	CH	1869	1994	126	D	J	64	Fiumicino	IT	1871	1985	115	P	A
19	Zermatt	CH	1901	1995	95	P	M	65	Genova	IT	1833	1987	155	P	J
20	Larnaca	CY	1882	1993	112	P	J	66	Linate	IT	1929	1985	57	P	A
21	Limassol	CY	1883	1993	111	P	J	67	Napoli	IT	1833	1990	158	P	A
22	Nicosia	CY	1882	1993	112	P	J	68	Padova	IT	1725	1990	266	P	M
23	Labe Decin	CZ	1888	1992	105	D	J	69	Palermo	IT	1807	1991	185	P	A
24	Praha	CZ	1876	1995	120	P	M	70	Roma	IT	1782	1984	203	P	A
25	Alger	DZ	1846	1993	148	P	A	71	Kufr Awan	JO	1938	1993	56	P	J
26	Constantine	DZ	1876	1993	118	P	A	72	Beyrouth	LB	1915	1969	55	P	J
27	Oran	DZ	1877	1993	117	P	A	73	Skopje	MK	1926	1994	69	P	M
28	Kom El Nadura	EG	1868	1957	90	P	A	74	Valetta	MT	1865	1960	96	P	M
29	Alicante	ES	1856	1993	138	P	A	75	Portela	PT	1864	1974	111	P	A
30	Barcelona	ES	1850	1991	142	P	M	76	Bistrita	RO	1875	1993	119	P	M
31	Murcia	ES	1863	1986	124	P	M	77	Dunarea Orsova	RO	1840	1993	154	D	M
32	Ajaccio	FR	1885	1993	109	P	M	78	Filaret	RO	1865	1993	129	P	J
33	Avignon	FR	1871	1993	123	P	M	79	Mures Arad	RO	1877	1993	117	D	M
34	Besancon	FR	1885	1984	100	P	A	80	Sibiu	RO	1852	1993	142	P	M
35	Bordeaux	FR	1842	1993	152	P	M	81	Sulina	RO	1876	1993	118	P	M
36	Cahors	FR	1851	1993	143	P	M	82	Ljubljana	SI	1851	1994	144	P	M
37	Castelnaudary	FR	1829	1993	165	P	M	83	Dunaj	SK	1901	1994	94	D	M
38	Gap	FR	1861	1993	133	P	M	84	Bratislava						
39	Joyeuse	FR	1900	1993	94	P	M	85	Ain Draham	TN	1885	1994	110	P	A
40	Lille	FR	1801	1979	179	P	A	86	Gafsa	TN	1897	1994	98	P	A
41	Loire Montjean	FR	1863	1990	128	D	J	87	Tunis	TN	1887	1994	108	P	A
42	Marseille	FR	1749	1993	245	P	M	88	Ankara	TR	1929	1993	65	P	A
43	Montpellier	FR	1851	1993	143	P	M	89	Bilecik	TR	1929	1993	65	P	A
44	Nice	FR	1865	1993	129	P	M	90	Bursa	TR	1929	1993	65	P	A
45	Paris	FR	1873	1993	121	P	A	91	Edirne	TR	1929	1993	65	P	A
46	Perpignan	FR	1851	1993	143	P	M	92	Eskisehir	TR	1929	1993	65	P	A
								93	Beograd	YU	1888	1992	105	P	M
								94	Taches Solaires	**	1700	1995	296	A	A

- Pas de temps selon lequel la série est disponible (la mobilisation des données n'est actuellement possible qu'au pas de temps annuel) :
- A, pas de temps annuel
- M, pas de temps mensuel
- J, pas de temps journalier
- Latitude de la station en degrés et minutes
- Longitude de la station en degrés et minutes
- Altitude de la station en m
- Surface du bassin versant, en km², à la section de mesure pour les séries de débits

Nous avons par ailleurs commencé à introduire des entrées graphiques telles que les tracés des cours d'eau jaugés ou la carte de leur bassin versant.

D'un point de vue informatique à chaque série correspondent au moins deux fichiers. Le nom de ces fichiers est constitué des huit premiers caractères du nom de la station. Un fichier d'extension « .dat » contient les données proprement dites et un fichier d'extension « .txt » contient les commentaires sur la série, sa longueur, son origine, etc... Pour les séries de débits un fichier d'extension « .bv » contiendra la carte du bassin versant.

Les premiers traitements

La base de données telle qu'elle vient d'être définie, est indépendante de tout logiciel de traitement ou de représentation. Nous avons pour notre part commencé à travailler sur « Mathematica » qui possède une bibliothèque très fournie de primitives pour le calcul, le graphisme et la cartographie. Nous pouvons aisément dans ce cadre, lire le fichier décrivant les stations et les fichiers « .dat » pour en faire deux listes, « stations » et « valeurs ». Nous disposons alors de l'ensemble des caractéristiques et valeurs permettant d'effectuer tous les traitements et représentations que nous pouvons imaginer.

Les premiers traitements ont consisté à visualiser le contenu de la base (figure 1) et à tracer la courbe de distribution des années d'observation.

La figure 2 donne la représentation spatiale des différentes stations prises en compte dans la base de données. Celles ci couvrent ce qu'on pourrait appeler les pays de la Méditerranée avec une acception très large de ce terme. L'extension spatiale des stations correspond en fait à celle du réseau AMHY. L'examen de cette carte montre les lacunes et donc les prospections à entreprendre pour les combler, en particulier en direction de l'Afrique du Nord, de la péninsule Ibérique, de l'Italie et de l'ex-Yougoslavie.

La figure 3 donne une première vision, encore assez grossière, de la structure des données pluviométriques annuelles. Elle représente le coefficient de corrélation de la partie commune des séries pluviométriques prises deux à deux en fonction de la distance. On constate une extinction de la corrélation aux alentours de 1500 km.

Bien d'autres traitements seront à mettre en place, tant au niveau de chaque station qu'au niveau spatial. Nous présentons seulement à titre d'illustration l'ajustement des tendances (contradictoires !) des séries de Bucarest-Filaret et de Palerme (figure 4).

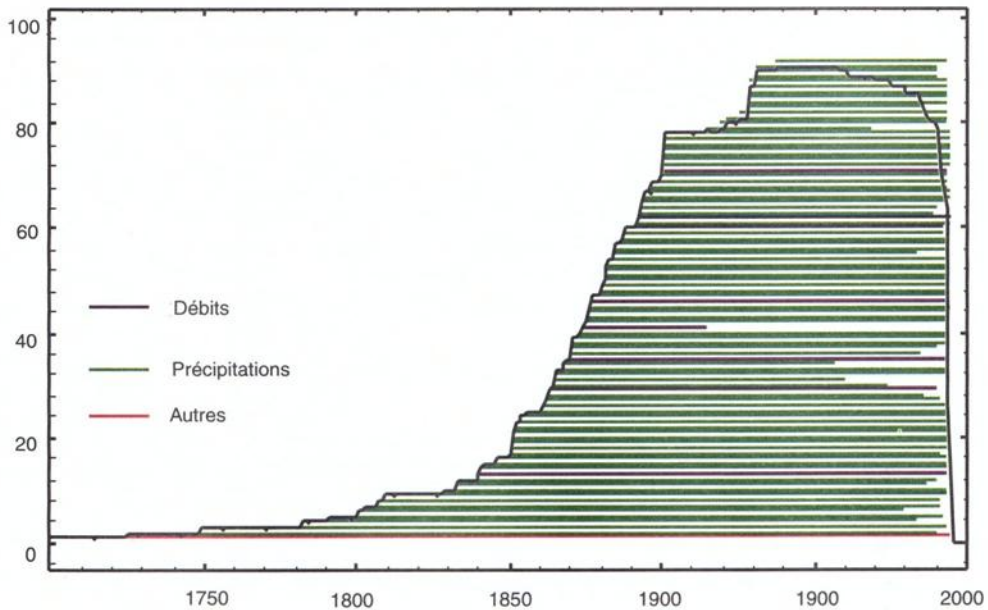

Figure 1 : Visualisation de la base de données (92 séries)
Figure 1 : Display of the database content (92 series)

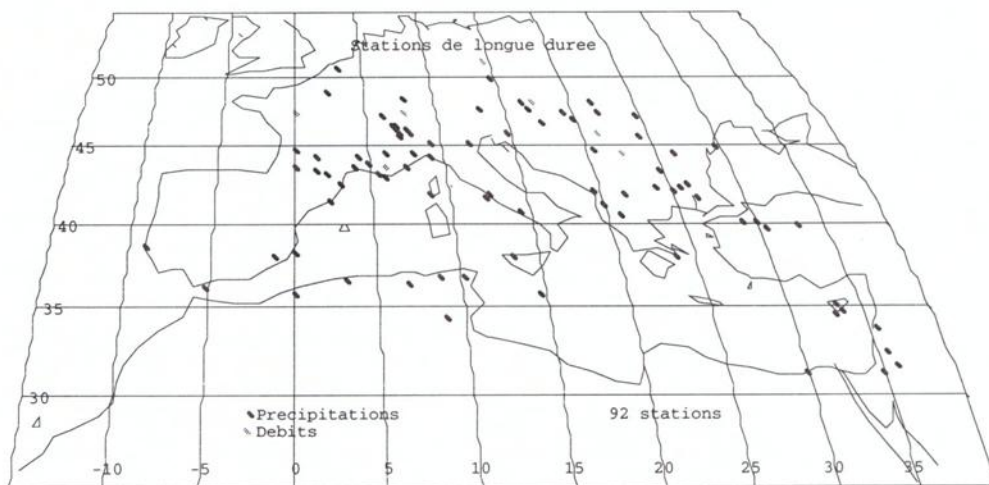

Figure 2 : Représentation spatiale des stations
Figure 2 : Spatial representation of the stations

Perspectives

Outre la recherche de nouvelles séries longues et le développement de nouveaux outils de traitement, notre projet est de mettre cette base de données ainsi que les outils qui l'accompagnent à la disposition de tous. Nous envisageons donc de les placer, dès que possible sur le site WEB de FRIEND-AMHY auquel tous les membres du réseau peuvent accéder grâce à un mot de passe.

Pour réaliser ces objectifs nous avons besoin de la coopération de l'ensemble des membres du groupe AMHY auxquels nous lançons ici un appel pressant pour enrichir ce travail en nous communiquant notamment d'autres séries relatives à tous les paramètres hydrométéorologiques.

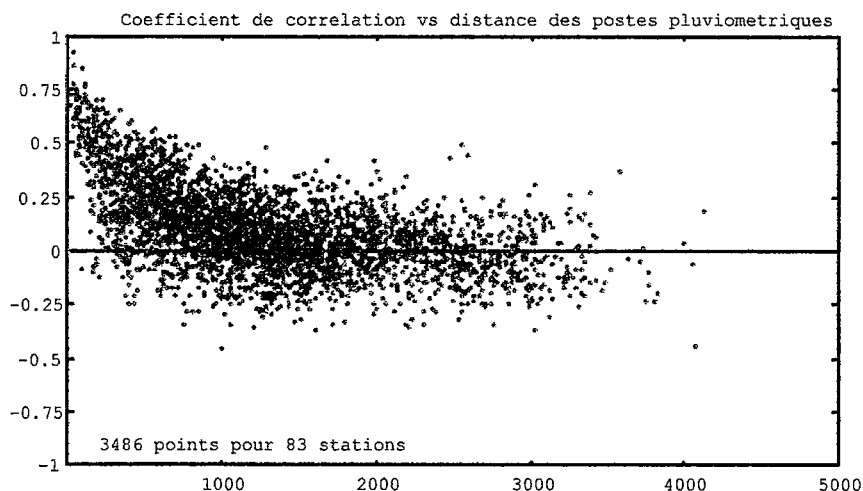

Figure 3 : Variation du coefficient de corrélation en fonction de la distance

Figure 3 : Spatial correlation coefficient variation, according to the distance

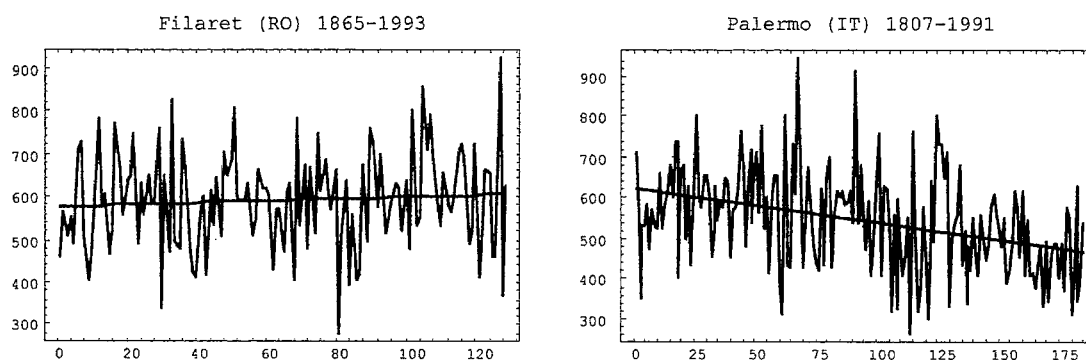

Figure 4 : Tendances comparées à Bucarest-Filaret (RO) et Palermo (IT)

Figure 4 : Compared trends at Bucarest-Filaret (RO) and Palermo (IT)

Remerciements

Nous souhaitons enfin remercier ceux et celles qui nous ont apporté leurs concours pour rassembler les longues séries réunies dans la base de données :

Aureli A. (Catane, Italie) ; Bargaoui Z. (Tunis, Tunisie) ; Barthe P. (Budapest, Hongrie) ; Ben-Sarah R. (Bet-Dagan, Israël) ; Benzarti Z. (Tunis, Tunisie) ; Bocquillon C. (Montpellier, France) ; Breil P. (Lyon, France) ; Brilly M. (Ljubljana, Slovénie) ; Bulu A. (Istanbul, Turquie) ; Camuffo D. (Padova, Italie) ; Carbonnel J.P. (Paris, France) ; Cernesson F. (Aix, France) ; Cole G. (Wallingford, Grande-Bretagne) ; Criminisi A. (Montaldo, Italie) ; Dakova S. (Sofia, Bulgarie) ; Denmak A. (Alger, Algérie) ; Duranyildiz I. (Istanbul, Turquie) ; Feissel M. (Paris, France) ; Fugaciu L. (Bucarest, Roumanie) ; Gustard A. (Wallingford, Grande-Bretagne) ; Guttierrez A. (Orléans, France) ; Hladny J. (Prague, République Tchèque) ; Iacovides I. (Nicosie, Chypre) ; Lantos P. (Meudon, France) ; Iiritano G. (Montaldo, Italie) ; Llasat C. (Barcelone, Espagne) ; Lopez-Arechavala G. (Madrid, Espagne) ; Malafosse A. (Lyon, France) ; Mangioti F. (Rome, Italie) ; Marochini E. (Algrange, France) ; Mercado A. (Rishon-Lezion, Israël) ; Merlier C. (Toulouse, France) ; Minarik B. (Bratislava, Slovaquie) ; Molnar L. (Bratislava, Slovaquie) ; Nobilis F. (Wien, Autriche) ; Nuri M. (Tirana, Albanie) ; Oancea V. (Bucarest, Roumanie) ; Olive P. (Thonon, France) ; Payen M. (Toulouse, France) ; Pretorian R. (Bucarest, Roumanie) ; Quintas L. (Madrid, Espagne) ; Radic Z. (Belgrade, Yougoslavie) ; Skoklevski Z. (Skopje, Macédoine) ; Spreafico M. (Berne, Suisse) ; Starosolsky O. (Budapest, Hongrie) ; Vafiadis M. (Thessalonique, Grèce) ; Vez E. (Lausanne, Suisse).

En espérant n'en avoir pas trop oubliés.

Brève Conclusion

Short Conclusion

A. Afouda

La présentation des séries longues fournit à l'hydrologue l'occasion de s'interroger sur l'importance de la notion d'échelle dans les phénomènes hydrologiques et sur celle des structures sous-jacentes. L'utilisation des méthodes fractales ouvre la perspective d'un approfondissement de la connaissance de ces structures. Comme l'ont montré ici *Hubert & Bendjoudi*, l'approche multifractale vise à relier échelle et intensité pour des processus en cascade concentrant la matière et / ou l'énergie dans un domaine spatio-temporels de plus en plus ténu. Cette nouvelle avancée dans la compréhension des phénomènes hydrologiques par l'utilisation de l'approche multifractale, d'abord conçue comme modèle phénoménologique de la turbulence, permet de rapprocher les structures des séries hydrologiques du fonctionnement dynamique des phénomènes météorologiques qui les ont générées. La dépendance de la dimension fractale du seuil de références définissant l'occurrence des pluies est une direction de recherche qui devrait, dans les prochaines années, permettre d'explorer les échelles spatio-temporelles de plus en plus fines et de répondre à des interrogations sur les manifestations possibles de la variabilité de la pluviométrie.

Le problème de la variabilité climatique et de la prédiction du climat est aujourd'hui au centre de préoccupation de toutes les grandes Organisations Internationales. La disponibilité des séries longues constituait un préalable incontournable pour la mise en évidence du caractère transitoire des régimes climatiques dans différentes régions. L'ensemble des communications rassemblées dans ce Chapitre 7 montre que les différentes bases de données des groupes FRIEND peuvent contribuer à lever ce préalable. En particulier, la mise en évidence des ruptures pour toutes les séries hydroclimatiques de l'Afrique de l'Ouest et du Centre, renforce l'hypothèse de l'existence d'états stables de régime de précipitations entre lesquels transiterait le système climatique par suite des fluctuations internes ou des perturbations aléatoires externes. Le modèle des séries hydrométéorologiques correspondant à ces états pourrait, comme ont eu à le souligner plusieurs auteurs auparavant (*Hubert & Carbonnel, 1987, Klemes 1974*), se traduire par la superposition de trois processus aléatoires dont l'un concernerait la longueur des durées de stabilité, l'autre le niveau moyen de stabilité, et le dernier un bruit autour de ce niveau moyen. Une exploitation rationnelle des séries longues pour la vérification de ces hypothèses pourrait fournir l'occasion de contribution majeure de l'Hydrologie scientifique à la compréhension de l'évolution des systèmes climatiques discontinus et à l'effort commun de recherches au niveau mondial.

oooo

Long series presentation gives the hydrologist the opportunity to reflect on the importance of the notion of scale in hydrological phenomena as well as that of subjacent structures. The use of fractal methods paves the way for a deepening of the knowledge of these structures. As shown here by Hubert and Bendjoudi, the multifractal approach aims at linking together scale and intensity for a chain of processes concentrating matter and/or energy in the spatiotemporal domain. This new advance in the understanding of hydrological phenomena by the use of the multifractal approach which is initially devised as a phenomenological pattern of turbulence helps to put together the hydrological series structures and the dynamic process of the meteorological phenomena which generate them. The fractal size dependence on the reference values that define rain occurrence is a research trend that should help in the coming years to explore reduced spatiotemporal scales and to answer questions about the possible phenomena of rainfall variability.

Nowadays, the major international organizations are very concerned with the climatic variability and prediction issue. The existence of long series constitutes a prerequisite for underscoring the transitional nature of climatic regime in different regions. All the papers collected in the current Chapter 7 show that the FRIEND groups' various databases can contribute towards meeting this prerequisite. Especially, the underscoring of disruptions in all West and Central Africa hydroclimatic series confirms the hypothesis of the existence of stable states in the precipitation regime through which the climatic system would be in transit as a result of internal fluctuations or random external disturbances. The model of hydrometeorological series corresponding to those states might, as underlined previously by many authors (Hubert and Carbonnel, 1987, Klemes 1974), find expression in the superposition of three random processes, one of which would deal with the length of stability duration, the second with the average level of stability and the last would deal with noises around that average level. A rational utilization of long series to confirm these hypotheses could give scientific Hydrology the opportunity to contribute significantly to the understanding of the evolution of discontinuous climatic systems and to the worldwide common research effort.

*References of chapter 7**Références bibliographiques du chapitre 7*

- AFNOR (1994) Codes pour la représentation des noms de pays ; Norme NF EN 23166, ISO 3166.
- Aka A., Lubes H., Masson J.M., Servat E., Paturel J.E., Kouame B. (1996) : Analysis of the temporal trends of runoffs in Ivory Coast - Statistical approach and phenomena characterization. accepté à Hydrological Sciences Journal
- Angot A. (1897) : Premier catalogue des observations météorologiques faites en France depuis l'origine jusqu'en 1950 ; Annales du Bureau Central Météorologique, année 1895, Paris.
- Boyland P. (1991) Guide to standard Mathematica packages, Wolfram Research, 306 p.
- Collectif (1991) Les données pluviométriques anciennes ; un patrimoine culturel et scientifique à mettre en valeur, ISBN 2-11-085 167-8, Météo-France et Ministère de l'Environnement, Paris, 59 p.
- Dhérent C., Petit-Renaud G. (1994) Using Archival Resources for Climate History Research, SC-94/WS.6, UNESCO, Paris, 72 p.
- Halsey T.C., Jensen M.H., Kadanoff L.P., Procaccia I., Shraiman B.I. (1986) Scaling measures and singularities, Phys. Rev. A, 33, p 1141.
- Hubert P., Carbonnel J.P. (1987) : Approche Statistique de l'Aridification de l'Afrique de l'Ouest. Journal of Hydrology, Amsterdam, 95, pp 165 - 183.
- Hubert P., Carbonnel J.P. (1989) Dimensions fractales de l'occurrence de pluie en climat soudano-sahélien, Hydrologie Continentale, Paris, 4, pp 3-10.
- Hubert P., Carbonnel J.P., Chauuche A. (1989) Segmentation des séries hydrométéorologiques, application à des séries de précipitations et de débits de l'Afrique de l'Ouest, Journal of Hydrology, Amsterdam, 110, pp 349-367.
- Hubert P., Friggit F., Carbonnel J.P. (1995) Multifractal structure of Rainfall Occurrence in West Africa, Z.W. Kundzewicz ed, New Uncertainty Concepts in Hydrology and Water Resources, Cambridge University Press, pp 109-113.
- Jones P.D. (1990) : Le climat des milles dernières années. La Recherche n°219 p 304-312
- Klemes (1974): The Hurst Phenomenon : a puzzle ? Water Resour. Res. 10 (4), pp. 675 - 688
- Kuusisto E., Lemmelä R., Liebscher M., Nobilis F. (1994) Climat and Water in Europe ; some recent issues, Technical Report of Rapporteurs, World Meteorological Organization, RAVI (Europe), W.G. on hydrology, Geneva, 30 p.
- Ladoy P., Schmitt F., Schertzer D., Lovejoy S. (1993) Analyse multifractale de la variabilité pluviométriques à Nîmes, C.R.A.S. Paris, Série II, 317, pp 775-782.
- Lovejoy S., Schertzer D. (1986) Scale invariance, symmetries, fractals and stochastic simulations of atmospheric phenomena, Bulletin of the AMS, 67, pp 21-32.
- Lovejoy S., Schertzer D., Tsonis A.A. (1987) Functional box-counting and multiple elliptical dimensions in rain, Science, 235, pp 1036-1038.
- Mandelbrot B.B. (1974) Intermittent turbulence in self-similar cascades : divergence of high moments and dimension of the carrier, J. Fluid Mech., 62, pp 331-350.
- Mandelbrot B.B. (1975) Les objets fractals, forme, hasard et dimension, Paris, 192 p.
- Mandelbrot B.B. (1977) The fractal geometry of nature, San-Francisco, 461 p.
- Nicholson S.E., Kim J., Hoopingarner J. (1988) : Atlas of African rainfall and its interannual variability. Department of Meteorology, Florida State University Tallahassee, Florida, USA.
- Olivry J.C., Bricquet J.P., Mahé G. (1993) : Vers un appauvrissement durable des ressources en eau de l'Afrique humide. Hydrology of Warm Humid Regions, IAHS Publ. 216, pp 67-78.
- Olsson J. (1996) Scaling and Fractal Properties of Rainfall, Department of Water Resources, Lund University, Report 1014.
- Paturel J.E., Servat E., Kouame B., Lubes H., Ouedraogo M., Masson J.M. (1997) : Climatic variability in humid Africa along the Gulf of Guinea - Part two : an integrated regional approach. Accepté à Journal of Hydrology
- Petit-Renaud G. (1991) : Variation de la pluviométrie en France depuis le siècle; dernier. Les données pluviométriques anciennes ; Météo-France, Paris
- Pettitt A.N. (1979) : A non-parametric approach to the change-point problem. Applied statistics, 28, n°2, pp 126-135.

- Raudkivi A.J. (1979) Hydrology, Pergamon Press, Oxford New-York, 479 p.
- Raulin V. (1864) Observations pluviométriques faites dans le sud-ouest de la France de 1714 à 1860, Chaumas-Bordeaux et Savy-Paris.
- Raulin V. (1881) : Observations pluviométriques faites dans la France septentrionale de 1688 à 1870, Ve Chaumas, Bordeaux.
- Réménieras C. (1976) : L'Hydrologie de l'Ingénieur. Eyrolles, Paris, 456 pp.
- Schertzer D., Lovejoy S. (1984) On the dimension of atmospheric motions, Turbulence and chaotic phenomena in fluids, T. Tatsumi ed., North-Holland, pp 505-508.
- Schertzer D., Lovejoy S. (1987a) Physical modeling and analysis of rain and clouds by anisotropic scaling and multiplicative processes, J. Geophys. Res., 92, D8, pp 9693-9714.
- Schertzer D. et Lovejoy S. (1987b) Singularités anisotropes et divergences des moments en turbulence, Ann. Sc. Math. du Québec, 11, pp 139-181.
- Schertzer D. et Lovejoy S. (1991) Scaling nonlinear variability in geodynamics: Multiple singularities, observables, universality classes; Non-linear variability in Geophysics, Scaling and fractals, D.Schertzer and S. Lovejoy eds, Kluwer, pp 41-82.
- Schmeltz F. (1891) : Observations météorologiques faites à Lille de 1757 à 1888, L. Daniel, Lille
- Servat E., Sakho M. (1993) : Incidences de l'instabilité des ressources en eau sur la gestion d'un système d'eau aménagé - Cas du Sassandra en Côte d'Ivoire. Hydrology of Warm Humid Regions, IAHS Publ. 216, pp 107-116.
- Servat E. (1994) : Identification et Conséquences d'une variabilité du Climat en AfRIque de l'ouest non sahélienne (ICCARE) - Présentation du programme. Antenne Hydrologique ORSTOM, Abidjan, Côte d'Ivoire.
- Servat E., Paturel J.E., Lubes H., Kouame B., Ouedraogo M., Masson J.M. (1997) : Climatic variability in humid Africa along the Gulf of Guinea - Part one : detailed analysis of the phenomenon in Côte d'Ivoire. Accepté à Journal of Hydrology.
- Sutcliffe J.V., Knott D.G. (1987) : Historical variations in African water resources. Influence of Climate Change and Climatic Variability on the Hydrologic Regime and Water Resources, IAHS Publ. N°168, pp 463-475.
- UNESCO (1974) : Débits de certains cours d'eau du monde. Paris
- Wolfram S. (1995) Mathematica, deuxième édition, Addison-Wesley, Paris, 1018 p.

Chapter 8

Regional hydrology, integrated water management, and some futures for FRIEND

Short introduction

P. Givone, A. Gustard, G. Oberlin

- What is the future of FRIEND?
- Are the current world-wide constraints on science and business too great for FRIEND projects to continue?
- Is a regional approach in hydrology, one that is both scientifically strong and operationally effective, now too great a challenge?

The answers to such questions are many and diverse and we have no wish to swamp readers with unnecessary conjecture. This volume's main goal is to report on the results achieved so far within the FRIEND initiative but we also wish to take the opportunity to give a preview of what might be expected from within FRIEND in the future. This has been done, by adopting both a thematic approach and by outlining proposed programmes, with an overall aim of developing hydrological sciences within FRIEND.

Future progress in regional hydrology will depend — as ever — on better knowledge of water regimes and improved modelling strategies, available throughout complete basins and at any scale, so that we can understand the whole hydrological network, from the headwaters to the estuaries.

ooooo

Brève introduction

P. Givone, A. Gustard, G. Oberlin

Quel futur pour FRIEND ?

Quelles conditions offriront à FRIEND les futures contraintes mondiales de développement scientifique et économique ?

Le pari d'assurer aux approches régionales en hydrologie, à la fois une forte base scientifique et une forte utilité socio-économique, est-il assuré d'être demain aussi réussi qu'aujourd'hui ?

Qui peut savoir ?

Les réponses à ces questions sont probablement diverses, et pourraient prendre autant de temps et de place que disponibles ..., mais ce rapport se doit de rendre compte des acquis de FRIEND, et non égarer le lecteur dans d'incertaines conjectures.

Cependant, il a tout de même été choisi de sélectionner ici quelques regards possibles sur ce qui est attendu pour demain dans FRIEND. Cela a été fait, soit via des aspects thématiques, soit via des aspects

de programmation. Parce que l'objectif de servir la gestion intégrée des eaux et de leurs milieux est une des motivations pour développer les sciences hydrologiques dans FRIEND, il a aussi été choisi de présenter ici quelques pistes futures possibles pour une telle gestion.

Il apparaît que ces pistes exigeront des progrès significatifs en hydrologie régionale, et en connaissance et modélisation des régimes. En outre, mais ceci est connu de longue date, ces progrès devront concerner tous les points d'un bassin versant, et à toutes échelles, de manière à réellement comprendre le fonctionnement de tout le réseau hydrographique, des ultimes parcelles amont jusqu'aux estuaires.

Le concept de ralentissement dynamique, en gestion intégrée des eaux

The concept of dynamic slowing down, in water integrated management

G. Oberlin, O. Gilard, E. Sauquet, E. Desbos

1 Introduction

Bien que l'aménagement et la gestion des eaux continentales dans leurs milieux naturels (sols, versants, bassins et réseaux hydrographiques) aient toujours existés, clairement explicités ou non, ils ont rarement fait l'objet d'une réflexion bien intégrée, mais plus souvent d'une approche sectorielle. Certaines réalisations, comme des barrage-réservoirs de grandes tailles dont le coût exigeait la coopération de plusieurs responsables de secteurs, ont vu émerger des approches pluri-sectorielles, mais le plus souvent limitées à l'ouvrage sensu stricto et non à l'ensemble du bassin et du cours d'eau concerné. Même dans ces cas, un seul secteur était le plus souvent dominant ou structurant, et le pluri-sectoriel restait souvent marqué, soit par des besoins de ressources en eaux insatisfaits, soit par des besoins en évacuation des eaux en excès. Les éléments concernés du cycle de l'eau étaient aussi le plus souvent bien typés, sinon en exclusivité mais au moins à dominante superficielle, ou souterraine, ou hydro-pédologique (irrigation). Hors ouvrage, et en particulier sur les milieux aquatiques continentaux par excellence que sont les cours d'eau (de toutes tailles), il n'y avait généralement pas de stratégie générale, d'objectif ou de vocation bien affichés, tout au plus des aménagements localement ciblés (moins d'inondations, hydroélectricité, etc...), et parfois une gestion minimale de type entretien/nettoyage. Le plus souvent, la cible était la simple évacuation des eaux pour limiter au maximum la présence d'eaux en excès en dehors des lits mineurs. Il est résulté de l'omni-présence de cette dernière réalité, une culture généralisée d'évacuation des eaux, perceptible jusque dans la législation (Code Rural en France, par exemple), et une vocation principale des cours d'eau, certes implicite mais néanmoins réelle, de réseau de drainage des eaux, celles-ci considérées le plus souvent comme étant plutôt en excès, et principalement indésirables.

Bien que les aspects positifs des eaux continentales et de (certains de ...) leurs milieux aient bien sûr toujours été pris en compte, et malgré un fort et récent développement de ces aspects, cette prise de conscience n'a encore jamais fait le poids vis-à-vis des réflexes fonciers de la société, fondamentalement hostiles aux eaux continentales et à leurs territoires. Les réseaux hydrographiques restent donc encore très majoritairement perçus comme des drains, et donc gérés et aménagés pour évacuer le plus rapidement (le plus loin ...) possible des eaux, très vite considérées comme en excès insupportable dès que leur niveau dépasse le minimum vital, ou dès qu'elles sortent de leurs lits mineurs, ou des quelques rares zones plus ou moins humides répertoriées et tolérées comme telles.

Cette vision trop sectorielle, et donc souvent trop marquée par les seuls besoins d'évacuation des eaux, a évolué très lentement, et on peut discriminer plusieurs étapes chronologiques qu'il a fallu franchir avant d'en arriver à un stade réellement concrétisable, et donc à une gestion intégrée faisable et non plus seulement intentionnelle.

2 L'émergence du concept de gestion intégrée des eaux et de leurs milieux

La première étape, déjà bien ciblée mais fort ambitieuse et encore très difficile à concrétiser, a été celle de l'émergence du concept lui-même. Cette émergence a été rapidement suivie par une pseudo-traduction opérationnelle : l'énoncé des liens internes au bassin versant, et donc de ce qui relie l'état d'un milieu aquatique à l'état de son bassin versant (gérer à l'échelle du bassin, etc...). Cette forte réalité est évidemment incontournable, et son rappel est d'un intérêt indiscutable. Il faut tout de même observer que sa traduction concrète est infiniment complexe : d'une part, elle interpelle la totalité des

comportements de la société et, d'autre part, elle concerne l'ensemble des éléments du cycle des eaux. La tâche est donc gigantesque et, au-delà de la satisfaction intellectuelle, cet énoncé est pour la gestion intégrée des eaux ce que le préambule d'une constitution est pour la vie quotidienne d'une démocratie : aussi fondamentalement indispensable que totalement insuffisant.

Un détail est révélateur de certains non-dits en la matière : une interprétation simplifiée de cette "gestion à l'échelle du bassin", et à traduction opérationnelle beaucoup plus simple (mobilisant moins d'acteurs, et moins d'éléments du cycle de l'eau), est de considérer le seul continuum du cours d'eau. On peut par exemple y exploiter dans une large mesure la simple conservation (relative ..., et aux apports/pertes latéraux près) des volumes d'eau s'écoulant vers l'aval, qui ouvre déjà de très larges perspectives d'aménagements et de gestion, comme le bien connu laminage des crues en aval s'il y a beaucoup de stockages ou de ralentissements en amont (Oberlin, 1994). Or cette réalité a été parfois, sinon ignorée du moins pas affichée, et par beaucoup des initiateurs de cette gestion intégrée. Sans doute la complexité même, et la largeur de l'assiette sociale, de l'échelle "bassin" évitaient-elles les traductions opérationnelles et foncières trop directement accessibles de cette échelle "cours d'eau". !

Cette limite étant rappelée, le développement de ce concept à l'échelle de tout le bassin n'est pas sans effet positif, mais il sert surtout à mobiliser progressivement la société, et non pas à lui donner des éléments concrets d'actions. Et comme il est dangereux de mobiliser des forces sociales sans leur donner assez rapidement, sinon en concomitance stricte mais au moins à terme proche, des moyens de concrétiser cette mobilisation (sous peine de faire retomber le soufflet, et pour longtemps), il était urgent de creuser le concept dans ses implications opérationnelles.

3 La redécouverte des liens entre ressources et crues

Une étape intermédiaire essentielle a été alors de rappeler l'existence, pour une société, des deux faces du Janus des eaux continentales : la face positive de la ressource, et la face négative des risques qui peuvent être induits par certains aspects des excès d'eau (inondations dommageables et alter). Mais ce rappel est en lui-même non porteur. Qu'en faire?

C'est là qu'intervient de façon majeure l'approche scientifique des eaux continentales, c'est-à-dire l'hydrologie. Une vision complète du cycle de l'eau, que ce soit via les bilans, ou via les cheminements de l'eau, ou via toute modélisation pourvu qu'elle soit complète (tout le cycle de l'eau, pas seulement un de ses aspects), montre une continuité fondamentale entre hautes et basses eaux, crues et étiages : il n'y a que des précipitations qui tombent, qui s'évaporent, qui se stockent et qui s'écoulent, selon divers cheminements et milieux, et avec des comportements qui se modélisent (se représentent) tous, même si cela peut être différent selon les approches spatiales ou temporelles et leurs échelles, ou selon qu'on s'intéresse aux "dentelles" en temps courant (chroniques $x(t)$ historiques) ou aux tempéraments/caractères/typologies (régimes en probabilités, comme dans FRIEND). Tout ceci est certes terriblement complexe, et avec des temps de réponse extrêmement différenciés, mais procède d'une remarquable cohérence et unité d'ensemble, avec des lois fondamentales (mécaniques, thermodynamiques, chimiques, biologiques, etc...) tout à fait solides et universelles. Et l'extrême complexité en analyse n'empêche fort heureusement pas de remarquables émergences en synthèse (cf par exemple nombreux travaux de FRIEND).

Cette unité au niveau des processus hydrologiques conduit donc le scientifique à proposer à la société de voir les crues, les apports et les étiages (les eaux en excès, celles en quantité convenable, et les rares) d'une manière aussi liée que possible : toute action sur l'une entraîne une action sur l'autre. Fort heureusement, cette étape semble assez aisément admise par la société en général. Peut-être que la culture hydrologique partielle apportée par les barrage-réservoirs, aménagements connus de tous de longue date et y compris pour certains de leurs principes (bilans entrées/sorties, fonctionnements saisonniers, etc...), explique l'appropriation relativement rapide de ce continuum parmi les non spécialistes. Il faut même parfois modérer les enthousiasmes, certaines traductions opérationnelles de

ces liens entre hautes et basses eaux étant parfois fortement exagérées (par ex. le rêve de faire disparaître toute sécheresse par de simples épandages de crues ... même à 9 mois d'intervalle).

On a déjà abordé plus haut (§ 2) la traduction rapidement opérationnelle de ces liens entre crues, moyennes eaux et étiages, à l'occasion de l'échelle intégrée de gestion concernant l'ensemble d'un cours d'eau sensu stricto (sans nécessairement impliquer son bassin versant sensu stricto). Mais l'application de la conservation (relative ..., aux entrées/sorties latérales près) des volumes le long d'un cours d'eau a posé également un problème aux scientifiques : les relations nappes/rivières, surtout en périodes de débordements, ont été longtemps mal connues (lacunes de connaissance) et jugées peu maîtrisables (lacunes de moyens de gestion).

4 La découverte de l'importance des liens entre eaux superficielles et souterraines

Un autre corollaire du cycle de l'eau, également lié aux processus générateurs d'écoulements superficiels, concerne donc ce relatif continuum entre eaux superficielles et eaux souterraines. Cette étape, encore balbutiante y compris chez certains scientifiques, a été plus laborieuse à faire émerger et reste longue à franchir. C'est moins la société qui s'est ici révélée sourde ou inconsciente, que les scientifiques et les spécialistes qui ont mis beaucoup de temps à analyser ce qui se passait réellement dans les sols. Il faut dire que c'est peu visible, que les modélisations validables ne peuvent concerner que des surfaces assez limitées, et que c'est le domaine où l'hétérogénéité est reine : le rôle majeur des macro-porosités dans les flux d'infiltration, ou le rôle prioritaire des lits mineurs dans les processus d'infiltration de cours d'eau pourtant (même largement) inondants, ou l'importance des flux hypodermiques (longtemps ridiculisés), ou les réalités concomitantes des refus à l'infiltration (Horton) et des surfaces contributives saturées (Cappus/Hewlet), ou les constantes de temps tout à fait différentes entre eaux de surface et eaux souterraines (mêmes très proches l'une de l'autre : par exemple celles d'une interface de berge de cours d'eau), etc..., ont fait bien des soucis aux hydrologues qui ont mis des dizaines d'années à commencer à y voir clair dans des processus aussi multiples qu'intriqués, et de surcroît souvent non stationnaires, y compris dans l'état des milieux (matrices) concernés.

De récents progrès, tant en approches analytiques (modèles couplés nappes/rivières) que synthétiques (régimes, cf travaux FRIEND), permettent aujourd'hui de quantifier (estimations ...) l'évolution des régimes influencés par des échanges nappes/rivières, y compris ceux modifiés par des mesures d'aménagement ou de gestion, comme par exemple la modification des zones inondables. Les résultats sont assez inattendus (voir par ex. Heydarizadeh, 1996, et fig. 1) : les flux d'échanges sont beaucoup plus importants et généralisés que prévus, tant en infiltration sensu stricto (avant que les écoulements ne soient organisés et concentrés) qu'en échanges nappes/rivières (lorsque les écoulements sont déjà concentrés dans les réseaux), avec des effets d'états antérieurs (rendement de l'écoulement selon l'état des sols et nappes) à beaucoup plus long terme que prévu (jusqu'à l'échelle interannuelle). S'ouvrent donc des perspectives de gestion intégrée, non seulement au titre de l'obligation sociale de ne pas dissocier eaux de surface et souterraines, mais aussi au titre des processus physiques concernés, et aussi au titre des impacts réciproques d'aménagements qui vont influencer des compartiments du cycle de l'eau parfois éloignés de ceux a priori envisagés : par ex. une politique de modification des épandages de crues, développée pour minimiser des dégâts dus aux inondations, va avoir (cela peut être positif ou négatif) de forts impacts sur l'état des nappes, ces dernières jouant en retour un rôle non négligeable sur ... les inondations !

5 L'obligation d'aménagement et de gestion dès les premiers milieux naturels parcourus par les eaux

Pour compléter ce tableau, et moins à titre d'étape chronologique que d'éclairage complémentaire, il faut dire quelques mots sur la gestion des eaux dans leurs milieux naturels. Malgré l'acceptation rapide (mais toutefois théorique : cf § 2) du concept de gestion à l'échelle d'un bassin, celui-ci n'a pas éliminé

pour autant une conviction encore assez répandue : on ne gère réellement les volumes d'eau que dans des structures artificielles, du barrage-réservoir au ... château d'eau. Outre le réflexe foncier à l'origine de cette conviction, qui souhaite n'avoir aucune contrainte de gestion des eaux sur une parcelle donnée (ou alors il faudrait exproprier pour affecter la parcelle à la gestion des eaux : le périmètre de la cuvette de retenue d'un barrage-réservoir), il y a sans doute la relative ignorance de l'importance potentielle des échanges avec le sol et le sous-sol (cf § 4), et du caractère souvent très transitoire de ces présences d'eaux. En effet, beaucoup de volumes d'eau peuvent être concernés, et donc gérés, même sur des terres non dévolues à l'eau, et donc la plupart du temps hors eau, voire sèches (drainées, etc...).

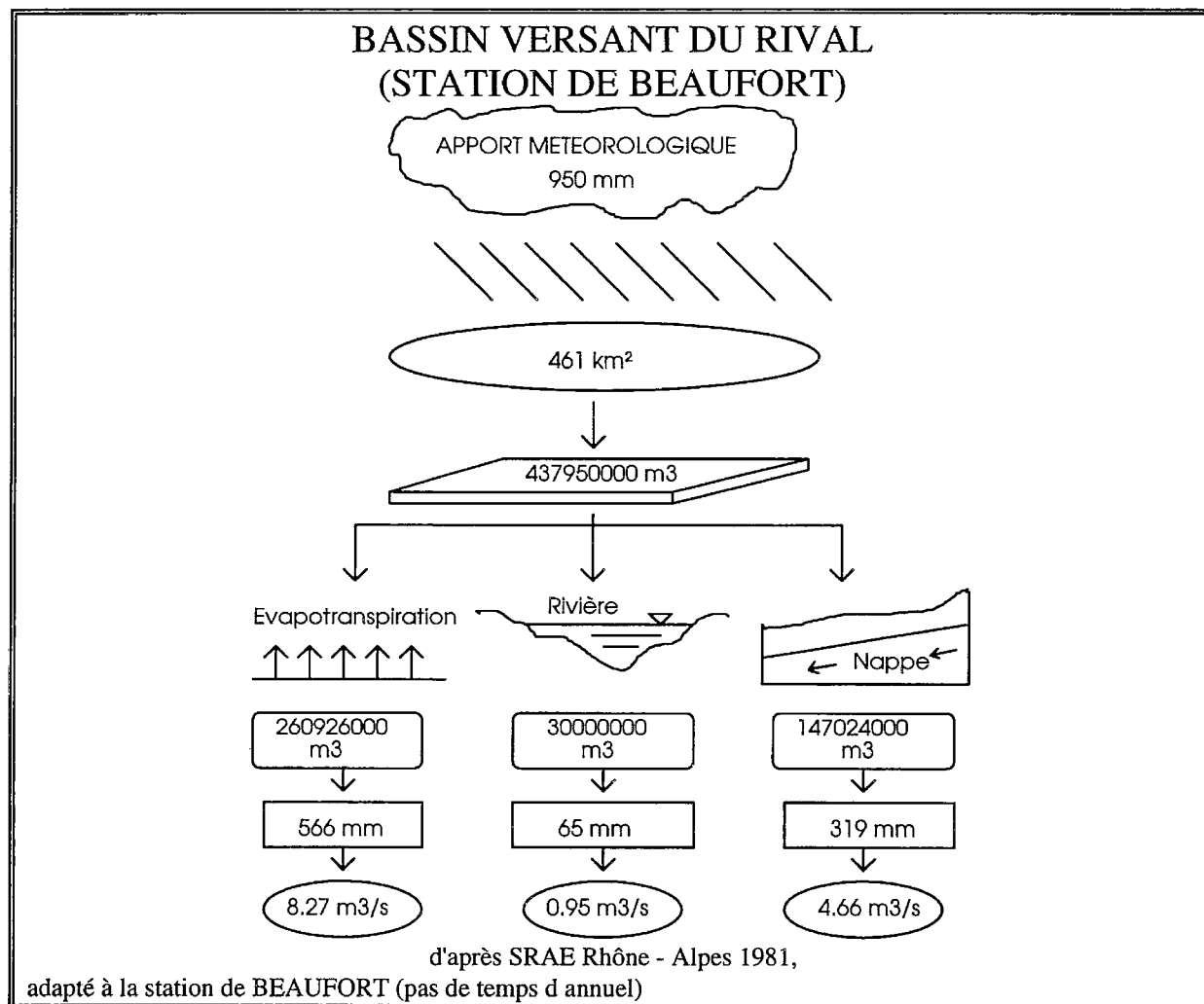

Figure 1 : Exemple d'un bassin versant assez grand (jusqu'au-delà de 650 km²) où plus de 80% de l'écoulement annuel (moyenne interannuelle) est souterrain.

Figure 1 : An example of medium-size basin (more than 650 km² downstream) where the underflow represents more than 80% of the annual runoff (interannual mean).

On retrouve là une conséquence directe et qui serait donc opérationnelle, au moins potentiellement, du concept de gestion intégrée à l'échelle des bassins (§ 2). On la cite ici volontairement en dernier car, hors cours d'eau et zone riveraine (lit majeur, espace de liberté, plaine alluviale, etc...), cette gestion sur "toute" (n'importe quelle) parcelle d'un bassin n'est pas sans poser des problèmes de faisabilité socio-économique, juridique, et tout simplement de bonne gestion (par exemple le respect de règles relativement subtiles par d'innombrables intervenants). C'est néanmoins un domaine qu'il faut obligatoirement explorer pour la gestion intégrée, sans doute en commençant par les terres riveraines des cours d'eau (en remontant de l'aval vers l'amont), en continuant par celles riveraines des structures à

rôles hydrauliques (fossés, talus, haies, ...) et en terminant par les versants sensu stricto, c'est-à-dire par la totalité du territoire restant : celle où les eaux météoriques arrivées au sol suivent leurs premiers processus hydroatmosphériques et hydro-pédologiques, bien avant ceux liés aux écoulements déjà plus ou moins concentrés.

6 Le ralentissement dynamique, comme règle d'or quasi-universelle pour fonder la gestion intégrée

Vis-à-vis de ces réalités physiques et sociologiques, le scientifique ne peut rester indifférent, s'il a le souci civique de la bonne valorisation des connaissances que la société lui permet de développer en soutenant ses travaux. Il faut donc se préoccuper de la finalité des connaissances en hydrologie, et de la manière dont ces connaissances sont exploitées par la société. En outre, compte tenu des forts enjeux fonciers de l'aménagement et de la gestion des eaux (depuis la fonction de production jusqu'à l'impact des régimes hydrologiques sur les terrains qui les subissent), il est également prudent que les scientifiques se préoccupent de cette contrainte, afin de développer les concepts et modèles pertinents pour que les connaissances hydrologiques soient bien utilisées là où c'est réellement utile ("là où cela fait mal" ...), et qu'elles ne soient ni incomprises, ni dévoyées.

A la lumière des points analysés ci-dessus, il est apparu que le couple "laminage/rétention" des eaux pouvait représenter un point d'ancrage initial de beaucoup de politiques de gestion des eaux et de leurs milieux. En effet, les eaux continentales étant une ressource précieuse pour de multiples usages, il est a priori légitime d'essayer de les retenir pour en prolonger les effets. Comme en outre toute rétention (épandages, etc...) est de nature à laminier peu ou prou le régime des crues, il y a corrélativement une modération potentielle des risques liés. Enfin, la plupart des milieux aquatiques bénéficient de la présence prolongée des eaux. Mais un tel couple, dédié plus ou moins à un "stockage" des eaux, ne doit pas casser les très nombreuses dynamiques qui accompagnent les cycles des eaux : dynamiques fluviales (transports solides, et les érosions/dépôts associés), dynamiques épuratrices, dynamiques biologiques (milieux lotiques), etc... Il serait pervers de pousser aux barrage-réservoirs, en ne voyant que les aspects volumiques de la rétention. Il faut donc obligatoirement qualifier ce couple avec une caractéristique forte, susceptible d'éviter des effets pervers. C'est ainsi que sont simultanément apparus le terme "ralentissement", qui sous-entend un stockage et une rétention qui ne soient pas "statiques", et le terme "dynamique", qui renforce ce sous-entendu, et renvoie aux nombreuses dynamiques des eaux.

Ce concept de Ralentissement Dynamique (R.D. ; Oberlin, 1994) paraît adapté à de très nombreux régimes. Il est plus facile à mettre en oeuvre en zones à faibles pentes, et à talwegs disposant d'un lit majeur large. Il peut également se développer en zone à pentes significatives, et à fond de talweg plus étroit, mais il faut alors davantage d'ouvrages et de moyens, et recourir souvent à des retenues transitoires mobilisant le lit mineur et ses abords immédiats (Sauquet, 1996).

Mais il y a une réserve, des précautions d'usages et l'obligation d'introduire un concept de vulnérabilité raisonnée.

- La réserve concerne les pertes par évaporation : ralentir signifie prolonger le séjour des eaux sur le continent, donc les exposer plus longtemps aux processus d'évaporation. Si c'est acceptable, voire souhaité (effets bénéfiques sur la végétation, les cultures, le climat local, etc...), et sans effets pervers (assez d'eau), le concept de R.D. devient généralisable. Si par contre des pertes par évaporation sont indésirables (pas assez d'eau), le R.D. peut se retrouver en contradiction avec d'autres objectifs et il faut alors, soit l'aménager en minimisant ces pertes, soit en user avec modération, et éventuellement très exceptionnellement y renoncer.

- Les précautions d'usage concernent surtout les modalités physiques et techniques du ralentissement. A base d'augmentation des rugosités, et de mise en place d'obstacles et ouvrages divers (seuils, etc..., plutôt petits mais nombreux et répartis), ces divers "freins" doivent au moins pouvoir "tenir" lors des fortes crues, à défaut de pouvoir être encore efficaces.

- Quant au concept de vulnérabilité (Desbos, 1995), il s'agit tout simplement de tenir compte du fait que si les inondations (ou les excès d'eau temporaires) sont incontournables, y compris d'ailleurs hors mise en oeuvre du R.D., elles n'en sont pas moins craintes, et le réflexe primaire en la matière est d'essayer localement de les éviter à tout prix. Pour dépasser cette contradiction, il s'agit avant tout de qualifier tout terrain vis-à-vis de cet aléa, et de définir des niveaux de risque (ceux induits par les excès en eaux) plus ou moins acceptables ou tolérables. C'est le concept de vulnérabilité qui peut répondre à cette question. Une fois défini et quantifié partout, il permet de répartir les eaux en excès selon une règle d'équité : "à chaque terrain toute la protection demandée, mais seulement cette protection" (voir dans ce Chapitre la contribution d'O. Gilard et alter).

Le propos de cette note n'est pas de développer les aspects d'aménagements et de génie civil induits par une mise en oeuvre du R.D. (voir fig. 3). On peut juste préciser qu'ils commencent au niveau des rugosités des sols, des choix de la végétalisation et du type d'entretien de la végétation, qu'ils se poursuivent par les structures en versants et celles des réseaux hydrographiques élémentaires amont (haies, talus, levées, fossés, cheminements favorisés en contrepentes topologiques, etc...), et qu'ils se terminent en aval par le dimensionnement réduit des lits mineurs, et par le développement des parcours transitoires des eaux de crues dans les lits majeurs. Mais l'essentiel ici est de présenter les aspects hydrologiques du R.D.. On peut situer un régime hydrologique issu d'un R.D. comme modéré par rapport au régime antérieur : les pointes de crues sont laminées (à des degrés divers selon leur fréquence/importance), et le volume ainsi retardé se retrouve, soit peu de temps après (décalage de l'ordre de quelque(s) fois le temps de réponse antérieur) si le ralentissement est modéré, soit jusqu'à fort longtemps après (effets jusqu'à des mois plus tard) si les eaux ralenties ont eu le temps de recharger les nappes (souvent via un lit mineur décolmaté, car actif pour motif de non-surdimensionnement). La figure 2 résume ces effets, dans une représentation de synthèse type xdf (variable-durées-fréquences), où la variable x est ici un débit-seuil dépassé continuellement (sigle QCXd(T)).

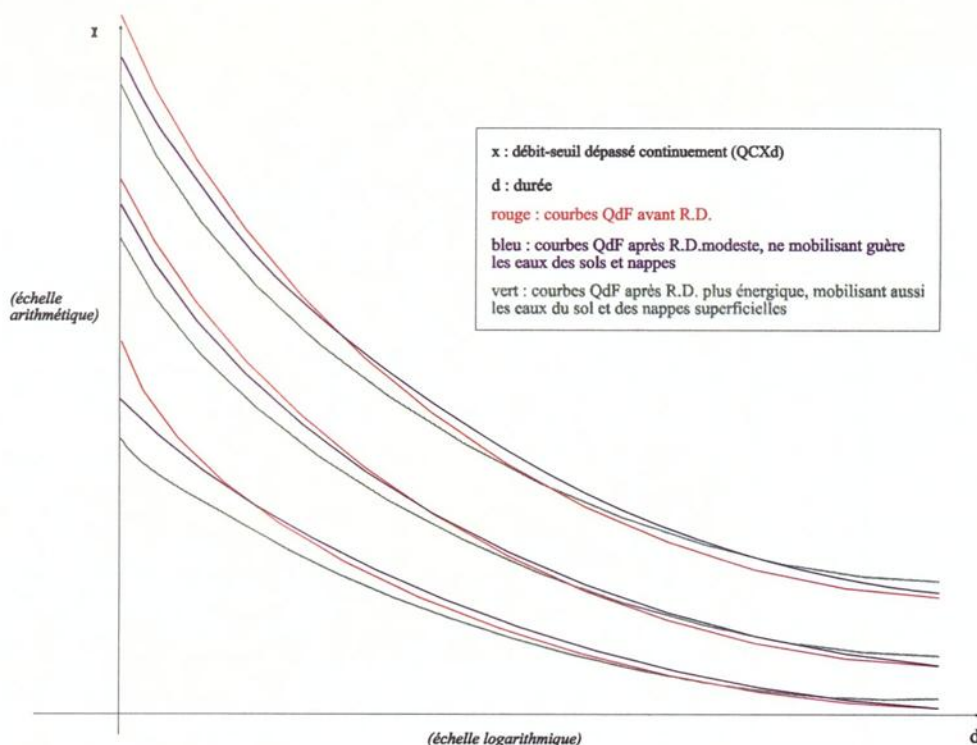
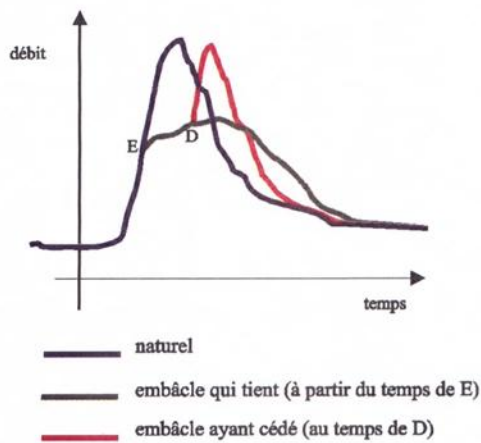
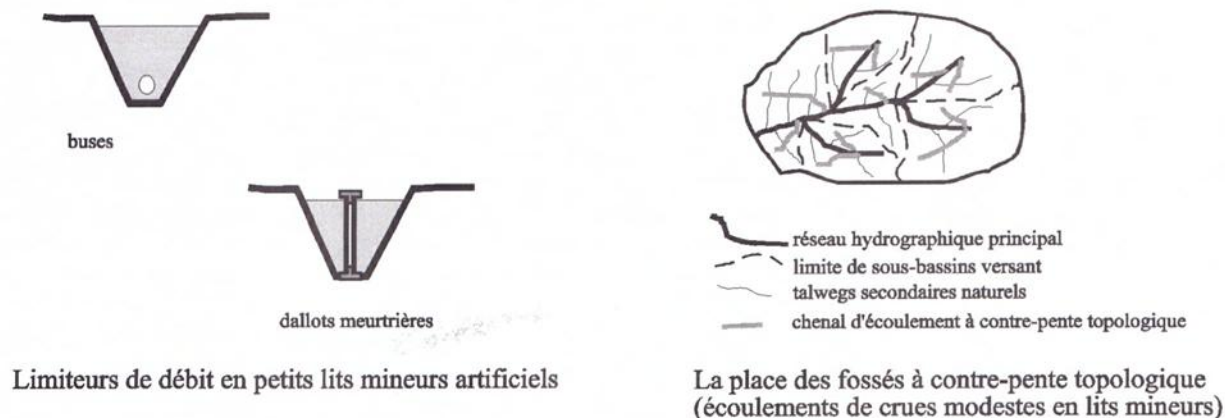

Figure 2 : Effets du Ralentissement Dynamique sur un modèle de synthèse de type "Débit (seuil)-durée-Fréquence".

Figure 2 : Effects of a Dynamic slowing down on a synthesis model "Discharge (threshold)-duration-Frequency".

Une fois établis des outils hydrologiques de qualification (modèles hydrologique sensu stricto, mais aussi modèles et/ou indices hydrauliques, hydrobiologiques, hydrochimiques, hydrogéomorphologiques, etc...), ce Ralentissement Dynamique peut servir de critère de pré-qualification du service général attendu de tout aménagement ou règle de gestion des eaux et de leurs milieux. Un préjugé favorable est attribué à ce qui favorise le R.D., et réciproquement. Ceci encourage structurellement nombre de mesures favorables, même lorsqu'elles sont d'intérêt peu démontrable économétriquement (avec des indicateurs monétarisés) à court terme et, réciproquement, aide à mieux analyser les conséquences de nombre de mesures n'allant pas dans le bon sens pour les eaux, et pourtant encore si fréquemment mises en oeuvre.



Embâcles sauvages et semi- contrôlées

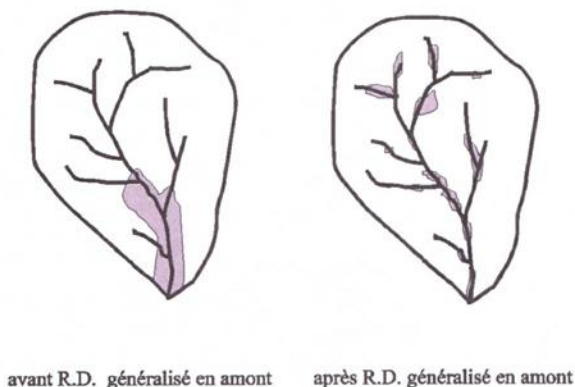

Localisation des eaux en excès dans un bassin

Figure 3 : Schémas présentant quelques uns des aménagements susceptibles de favoriser le Ralentissement Dynamique, et leurs effets spatiaux et temporels.

Figure 3 : Schemes presenting some hydraulic structures able to develop a Dynamic Slowing down, and their spatial/temporal effects.

7 Conclusion et perspective

L'avenir dira si cette règle d'or du Ralentissement Dynamique a vocation à devenir réellement structurante, voire peu ou prou contraignante au sens d'une règle réellement appliquée, qui passe dans

la culture des aménageurs, des gestionnaires, des riverains et des usagers. On peut d'ores et déjà constater que nombre de mesures récentes, qu'elles soient seulement incitatives, déjà règlementaires ou même légales, procèdent de facto de cette règle (De Lanay, 1995). Sa généralisation, et son éventuelle "imposition" a priori, ne sont donc pas hors de portée (Gilard et al., 1996). L'avantage principal de sa généralisation serait de renverser les tendances par rapport à la situation actuelle. Aujourd'hui, la norme reste l'évacuation, et son développement se fait spontanément, et souvent même sans avoir à argumenter. Par contre, retenir des eaux de manière dynamique, c'est-à-dire leur faire emprunter, même très transitoirement, des parcours fonciers non attribués exclusivement à l'eau, reste difficile, et demande à être fortement argumenté (même si l'intérêt en est évident), et reste toujours à la merci d'une annulation ultérieure, du moins dans le cadre culturel actuel.

Si le R.D. devenait la règle, tous ces aménagements et gestions favorables à l'eau et à ses usages, se verraient reconnus a priori. Ce seraient, à l'inverse, les accélérations d'évacuation qui exigeraient des justifications à argumenter sérieusement. Cette règle favoriserait l'intérêt général, et l'intérêt à terme de la société, de par une meilleure qualité des milieux, une meilleure disponibilité de la ressource, et une réduction des risques d'inondations dommageables via une répartition plus judicieuse des eaux en excès.

Il faudrait alors que la science hydrologique soit préparée aux enjeux de ce R.D.. Nombre de travaux menés en hydrologie de synthèse, et en hydrologie régionale, paraissent bien adaptés à servir en connaissances hydrologiques, en concepts et en modèles, cette règle d'or. Et c'est particulièrement le cas de nombre de travaux menés dans le cadre de FRIEND.

An hydrological definition of flood vulnerability.

Une définition hydrologique de la vulnérabilité aux inondations.

O. Gilard

1 Le risque d'inondation.

La notion de risque d'inondation est une notion complexe [Chastan et al. 1995] faisant intervenir de multiples facteurs dont le premier reste, bien entendu, l'eau, apportée généralement par la pluie tombée sur un bassin versant et la crue qui en résulte dans la rivière qui le draine. Ce comportement physique n'est cependant pas suffisant pour justifier une situation de risque, et, par exemple, l'inondation d'une forêt alluviale ne débouche pas sur un risque. Celui-ci dépend de l'interférence entre le débordement de la rivière et la valorisation par les activités humaines du territoire concerné. La notion de risque traduit en fait un conflit entre "la part de l'eau" traduisant une variabilité naturelle du système hydrologique constitué par un bassin versant et la "part de l'homme" traduisant l'usage que la société fait de son territoire. De ce "conflit" résulte à l'occasion des crues les plus fortes des dégâts économiques parfois considérables qui nous amènent à essayer de mieux comprendre les causes de ces dommages afin d'en réduire l'impact économique. Pour essayer de clarifier cette notion afin d'en faciliter l'analyse nous faisons appel à deux concepts bien différenciés que sont l'aléa et la vulnérabilité [Molin Valdes 1994] [Gilard et al. 1996].

1.1 Le concept d'aléa (figure 1).

L'illustration de ce concept est donné par l'exemple suivant : considérons une maison individuelle qui peut être construite soit en bordure immédiate d'un cours d'eau, soit à quelques centaine de mètre de celui-ci. Intuitivement, il apparaît que l'on attribue un "risque" plus grand à la première localisation proche de la rivière qu'à la seconde. Pourtant, l'hypothèse d'une maison identique se traduit aussi par le fait qu'en cas d'inondation de l'une ou de l'autre, les dégâts seraient de même nature dans les deux maisons. Ce qui les différencie est en fait uniquement les caractéristiques de l'éventuelle inondation : sa profondeur, sa durée, sa probabilité ...

C'est ce concept que traduit le terme d'aléa : il dépend uniquement du fonctionnement hydrologique et hydraulique du bassin versant et de son réseau hydrographique et peut être analysé avec les méthodes hydrologiques et hydrauliques. Toute parcelle du territoire peut être caractérisée par son propre niveau d'aléa.

1.2 Le concept de vulnérabilité (figure 2).

Imaginons cette fois une même parcelle de terrain à proximité d'un cours d'eau et les usages différents que l'on peut en faire, depuis une friche agricole jusqu'à un centre urbain en passant par une culture de céréale, une maison isolée et une petite usine. Intuitivement, nous dirons là encore que le risque n'est pas le même pour ces différentes situations et qu'il va croissant de la friche au centre urbain, en passant par les différents exemples cités. Pourtant, la dynamique des crues de la rivière ne peut pas être influencée par les modifications d'usage de cette seule parcelle et leurs caractéristiques physiques en sont totalement indépendantes. C'est en fait le niveau de dommages potentiels qui différencie ces simulations, dommages directs ou indirects, ainsi que leur perception sociale.

C'est ce concept que traduit le terme de vulnérabilité : il ne tient pas compte de la probabilité de cette inondation ni de ses caractéristiques physiques mais seulement des enjeux et de la perception sociale. C'est donc un concept essentiellement socio-économique et non hydrologique ou hydraulique, qui lui aussi peut caractériser chaque parcelle de terrain en tenant compte de l'usage que l'on en fait.

même occupation du sol et site différent

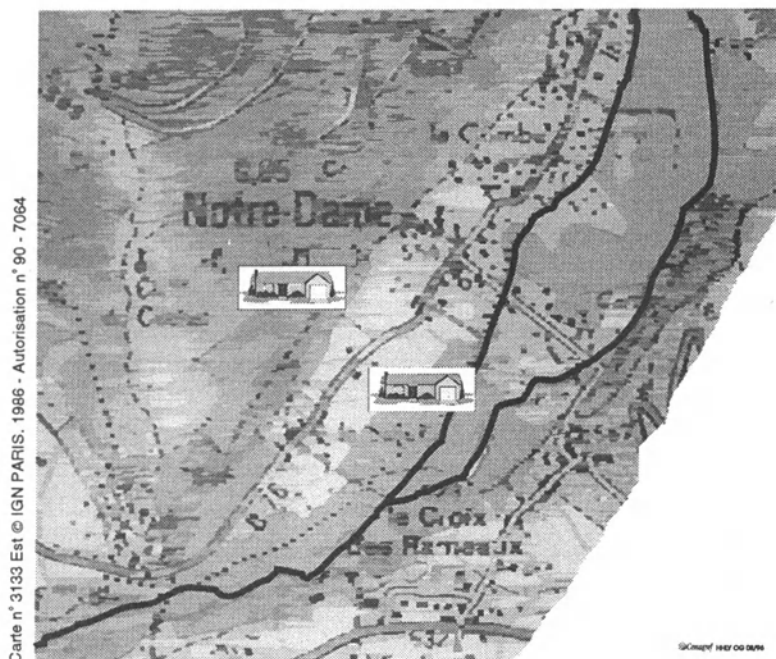

Figure 1 : Illustration du concept d'aléa
Figure 1 : Hazard concept illustration

même site et occupation du sol différente

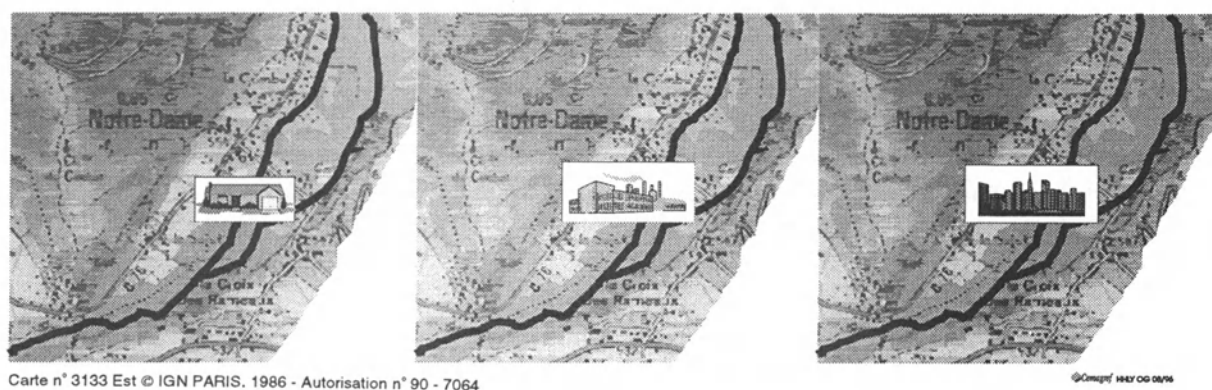

Figure 2 : Illustration du concept de vulnérabilité
Figure 2 : Vulnerability concept illustration

1.3 La modélisation conceptuelle du Risque.

Pour analyser une situation de risque sur un territoire donné, il faut combiner les deux facteurs précédents que sont l'aléa et la vulnérabilité au droit de chaque parcelle et il en résulte une définition du risque comme étant la confrontation sur une même parcelle d'un certain niveau d'aléa, défini par les caractéristiques physiques des crues, et d'un certain niveau de vulnérabilité, défini par les caractéristiques socio-économiques de l'occupation du sol. Cela induit tout de suite le fait qu'il peut

exister des risques positifs ou négatifs, ces derniers exprimant en fait une "marge de sécurité" disponible, remarque qui débouche sur l'identification de possibles aménagements pour résoudre la situation et qui viseront à utiliser ces "marges de sécurité" pour réduire le risque ailleurs. De même, cette analyse du risque implique que les aménagements qui permettent de maîtriser le risque peuvent être soit des aménagements qui modifient l'aléa (ce sont les classiques travaux d'aménagement de rivière comme les recalibrages ...) soit des aménagements qui modifient la vulnérabilité (correspondant à la maîtrise de l'occupation des sols ...).

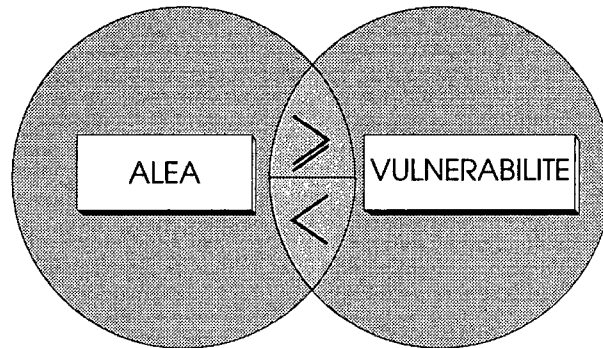

Figure 3 : Modélisation du risque

Figure 3 : Risk modelisation

2 Quantification hydrologique de la vulnérabilité.

Le concept de vulnérabilité ayant été défini, nous allons analyser comment il est possible de le modéliser et de le quantifier pour permettre une étude quantifiée du risque d'inondation.

2.1 Les approches classiques.

L'analyse de la dimension socio-économique du risque d'inondation a fait l'objet de nombreux travaux essentiellement orientés vers la quantification économique et monétaire des dommages, procédure retenue dans le cadre de l'application des textes réglementaires en la matière [Min. Environnement 1990]. " Cela suppose en particulier que ... chaque individu peut exprimer ses préférences, ou changement d'utilité, sous forme d'équivalents monétaires " [Torterotot 1994]. Cette approche, pour intéressante qu'elle soit, se heurte pourtant à des difficultés difficilement surmontables et ne débouche pas toujours sur une prise en compte appropriée du risque dans les choix d'aménagements ultérieurs. L'une des difficultés est liée au caractère difficilement monétarisable de certains dommages liés aux inondations. Sans parler des vies humaines[♠], il existe de nombreuses valeurs non monétaires qui peuvent être affectées par une inondation comme la valeur affective accordée à certains objets qui peuvent être détruits. De même le stress psychologique subi par les victimes est difficilement quantifiable monétairement, sauf pour partie par les troubles de santé qui en découlent, mais rentre pourtant dans la perception sociale du risque partagée par les habitants d'une vallée alluviale. Le caractère probabiliste et aléatoire des crues crée une difficulté supplémentaire puisque, s'il est relativement facile de quantifier les dommages dus à un événement de référence donné (une crue historique observée, une crue de référence, décennale ou centennale), il est plus difficile de tenir compte de tout le régime hydrologique du cours d'eau et de tous les événements possibles depuis les

[♠] les causes de décès liées à des inondations relèvent plus d'une mauvaise culture individuelle du risque que d'un problème d'aménagement du territoire, sauf dans certaines situations assez particulières et peu nombreuses. Cette "inculture" se traduit par une sous-estimation systématique des risques qui peut déboucher sur des comportements dangereux en période de crise et entraîne une mauvaise réception et compréhension des messages d'alerte et de prévention.

plus courants jusqu'aux plus extrêmes. La seule notion de coût annuel moyen des dégâts ne suffit pas en général à donner une information pertinente pour déterminer des choix d'aménagement judicieux. Enfin, ce type d'approche ne permet d'aboutir in fine qu'à une répartition spatiale de l'aléa et, en particulier, ne permet pas de qualifier au niveau de chaque parcelle la vulnérabilité. Or, la gestion du risque d'inondation étant de manière évidente liée à une problématique d'aménagement du territoire, il est nécessaire de donner aux acteurs de cet aménagement (riverains, décideurs locaux, administrations...) des arguments qui leur permettent de choisir entre différents choix d'aménagement et d'usage des sols.

2.2 La quantification hydrologique.

Une nouvelle approche peut être proposée pour ce problème. Elle consiste à choisir des paramètres de nature plutôt hydrologique pour exprimer la vulnérabilité. C'est à dire que, à l'inverse de l'approche classique qui cherche à utiliser une certaine connaissance de l'hydrologie et de l'hydraulique pour l'exporter dans le champ de l'économie et la valoriser dans ce contexte disciplinaire, il est possible en sens inverse d'exporter une connaissance disponible dans le champ de l'économie, voire de la socio-économie, et de la convertir en variables de nature hydrologique. C'est ce que traduit la notion de Risque maXimal Acceptable (RXA).

La définition d'un risque maximal acceptable repose sur le constat que les moyens d'interventions à notre disposition ne permettent pas de supprimer totalement le risque. Cela étant reconnu, il faut donc être capable de définir un niveau de risque acceptable, et ce d'une manière collective puisque l'incidence spatiale des inondations et les coûts mis en jeu rendent inopérante toute analyse individuelle. Ce risque acceptable doit d'une part tenir compte des seuils qui conditionnent l'apparition des dégâts, seuils qui peuvent s'exprimer en terme de hauteur d'eau, durée des inondations, éventuellement vitesse du courant. Et d'autre part il doit qualifier en terme de fréquence ce que la société est prête à accepter en la matière : cela revient à donner explicitement une "fréquence de tolérance" à certains dégâts. Cela est fait de toute façon implicitement dans les processus d'aménagement classique où, par exemple, le dimensionnement d'ouvrages hydrauliques pour une crue de projet donnée traduit en fait l'acceptation des dommages pour une crue plus forte que la crue de référence. Le Risque maximal Acceptable se traduit donc par une expression en Fréquence, durée, profondeur et vitesse de l'inondation "acceptable", ces caractéristiques étant définies pour toute occupation du sol et donc pouvant être affectées à chaque parcelle de terrain.

On peut proposer des normes-guides de vulnérabilité [Desbos 1995] en fonction de l'occupation des sols, qui servent de base de départ à une négociation locale de la vulnérabilité, permettant de tenir compte des spécificités locales qui conditionnent la perception du risque : histoire, type de crue, culture locale . . .



Figure 4 : Exemples de Risque maXimal Acceptable

Figure 4 : maXimal Tolerable Risk Examples.

2.3 La mesure de la vulnérabilité.

Une fois définis ces paramètres qualifiant la vulnérabilité d'une parcelle, il est possible de les traduire en une "mesure" objective de la vulnérabilité en s'appuyant sur la connaissance des régimes hydrologiques que donnent les modèles synthétiques en Débit-durée-Fréquence [Galéa et al. 1993]. Ces modèles déterminent en fait l'unité de mesure locale de vulnérabilité que traduit une année de période de retour.

En effet, grâce aux propriétés de biunivocité entre débits, durées et fréquences, et donc entre profondeurs, débits, durées et fréquences (grâce aux lois de tarages locales qui permettent de relier de manière biunivoque débit et profondeur) une succession de projections mathématiques permet de définir un "équivalent" en terme de période de retour de tout couple (durée, fréquence) ou de tout triplet (profondeur, durée, fréquence) exprimant la vulnérabilité d'une parcelle. Il suffit de se ramener à un équivalent "durée nulle" et "profondeur nulle" et de définir la période de retour de la crue qui apporte cette inondation "quasi-nulle" sur la parcelle concernée. Cette période de retour, définie de manière non équivoque et dotée d'une unité, constitue réellement une mesure de la vulnérabilité de chaque parcelle.

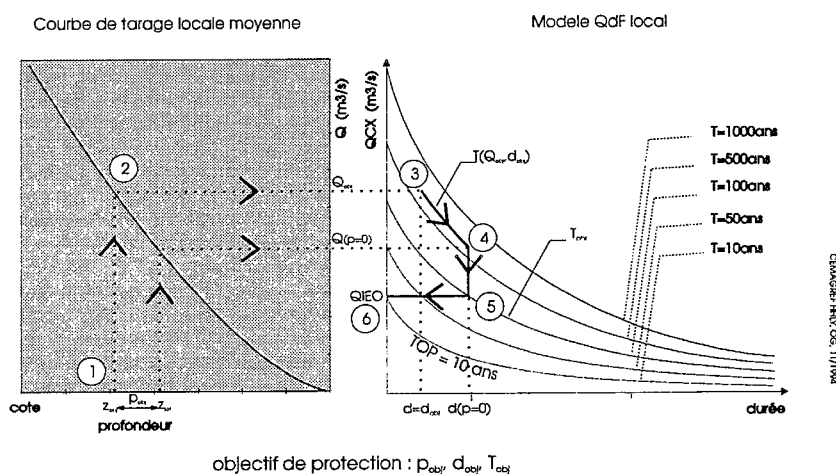

Figure 5 : Calcul de la période de retour équivalente à l'objectif de protection

Figure 5 : Calculation of protection objective equivalent return period

3. Utilisation et conclusion.

Cette définition de la vulnérabilité hydrologique et la quantification qu'elle propose permettent de dresser des cartes de vulnérabilité tout à fait similaires aux cartes d'aléas, plus classiques, qui décrivent l'incidence spatiale des zones touchées par des crues plus ou moins fortes. La comparaison de ces deux types de cartes traduit cartographiquement la situation de risque de chacune des parcelles concernées. Cette démarche d'analyse du risque en le décomposant en ces deux éléments que sont l'aléa et la vulnérabilité, quantifiés de manière compatible pour pouvoir être comparés entre eux, ainsi que le formalisme cartographique qui en découle est le fondement la méthode "inondabilité" [Gautier 1991] [Cemagref 1996]. Appliquée de manière généralisée à l'analyse des risques d'inondation, elle devrait permettre de réconcilier les approches "maîtrise du risque" et les approches "gestion de la ressource en eau" et de généraliser la règle d'or du ralentissement dynamique dans les processus d'aménagement du territoire avec de nombreux effets bénéfiques, outre sur la maîtrise du risque et la ressource en eau disponible, sur la qualité des milieux aquatiques, le maintien des équilibres naturels et, en conséquence, la baisse des charges récurrentes d'entretien des ouvrages hydrauliques.

Remerciements : ce travail a bénéficié des premiers résultats du projet de recherche FLOODAWARE financé par le 4^e PCRD de la Communauté Européenne. Il a aussi profité du soutien du ministère de l'Environnement par le biais du programme de recherche sur les risques naturels.

Regional hydrological determinants for instream ecology

Déterminants hydrologiques régionaux de l'écologie des rivières

P. Breil

1 Why develop regional 'EcoHydrology' inside general hydrological science?

The instream ecosystem balance is assumed to be a good measure of 'river health', in the sense that it is a result of all influences on the running water. For sustainable river management which maintains the renewable surface water resource, there is a need to qualify and quantify such 'river health levels'.

One idea is that for the ecological community, local assemblage organization is constrained not only by local processes, but also by larger scale environmental factors and available species pool characteristics (Poff & Allan, 1995). This means that regional determinism is partly linked to watershed characteristics which determine both flow response to rainfall and local instream morphology. Regionally synchronised observations in community assemblage variations could sustain this idea.

Main ecological theories like the 'habitat template concept' (Southwood, 1977), the 'intermediate disturbance hypothesis' (Connell, 1978), the 'disturbance-productivity-diversity model' (Hildrew & Townsend, 1987) and the 'patch dynamics concept' (Townsend, 1989) state a conceptual relationship between species richness and disturbance frequency in environmental conditions (see comparison in Statzner & Resh, 1993). These are dynamic equilibrium based theories. This suggests that for lotic (running water) ecosystems, species abundance and distribution may be explained by the spatial and temporal distribution of physical and temporal conditions and trophic resources. To verify such theories, stream ecologists often use biological data sets coupled with statistical flow characteristics to express temporal variability in aquatic habitat. The main results for ecohydrological perspectives are given below.

Using 15 river systems and 1065 fish sampling sites, Horwitz (1978) verified that the gradient of species richness was shown to be correlated with patterns of flow variability and noted a general increase in the variability of flow toward the headwater. These conclusions confirmed many previous results from other authors and sustain the variability basis of ecological theory. He also found that no single factor, such as flow, is responsible for all the variations in the distributions of stream fishes, although the variability relation between discharge and other factors may be stronger in rivers with more variable flows.

Increase in richness of fish species from upstream to downstream was often noted during large scale studies (Changeux & Pont, 1995). Such a general trend is thought to be dependent on aquatic habitat evolution from headwaters to rivers. For this reason many authors use classic statistics like range and skewness coefficients to summarise the frequency distribution of flow series when correlating between temporal variability and instream community patterns. However, to address the specific question of periodic phenomena in ecological theories, Colwell (1974) developed a contingency table procedure to separate the predictability of temporal conditions into contingency and constancy measures. This procedure was checked by Stearns (1981) to assess its performance on the metric, nominal and ordinal data often met in ecological data set descriptions. Overall performance in determining periodic phenomena was judged to be good enough. As environmental periodic fluctuations are assumed to structure long term fish community patterns (knowing existing regional historical pools), the predictability of predefined hydrological characteristics is included in many correlation studies between fish diversity and the temporal variability of hydrological variables.

For stream ecologists, the broad scale importance of hydrologic variability on lotic community

structure needs to be quantified in order to reliably determine the temporal and spatial scale(s) appropriate in generalizing patterns and processes in lotic communities. Poff & Ward (1989) proposed for North America, a three-dimensional flow representation based on flood frequency, flood predictability and overall flow predictability. For that purpose they used long-term discharge records from 78 streams. The ecological consistency of 3-D flow space was discussed at the population and community levels, pointing out that only multi-year sampling effort will allow confirmation of its relevancy. However, the position of streams in 3-D flow space provide a conceptual framework for evaluating *a priori* the relative importance of abiotic and biotic factors in regulating population and community processes and patterns. The same rivers were used by Poff (1992) to assess the potential effect of climate change at the regional scale from an ecological perspective. Two important descriptors in this case seem to be the frequency of bankfull discharge and the seasonal predictability with which flooding occurs. These factors will be represented locally, but also need to be assessed at a regional scale. More realistic representation will come from critical habitat elements called refugia which are defined as reservoirs of biodiversity. Past floods affect the channel form and substrate stability, which in turn influence the refugia. Spatial and temporal connectivity of refugia will influence local and regional persistence of species and depend largely on the hydrologic regime, in particular the timing and duration of appropriate flows at and over bankfull discharge. Hydrological variability descriptors were also used on 34 sites in northern USA by Poff & Allan (1995) to explain functional organization of stream fish assemblages. They achieved 85% accuracy of the correct ecological groups and concluded that anthropogenic disturbances could modify stream fish assemblages in this region.

Another New Zealand study (Jowett & Duncan, 1990), based on 130 sites, found that flow variability indices are correlated to morphological and hydraulic characteristics: the longitudinal variability of water depth and velocity increased with flow variability, indicating a more pronounced pool/riffle structure in rivers with high flow variability. Mean annual water velocity at different flow levels was higher in rivers of low flow variability. This was correlated to periphyton communities and trout distribution and abundance. Weighted usable area, a micro-habitat measure, tended to increase with flow variability. Hydrological variability regionalization factors were in order of: climate, water storage and transmissivity, catchment area and lakes, where variability decreased by the slowdown effect.

Hughes & Barry (1989) wrote that recent stream ecological research has stressed the importance of hydrological processes in explaining spatial and temporal distributions of lotic biota at the regional, catchment, stream-reach and micro scale. In a quantitative approach, these authors used 138 stream gauges to regionalize 16 hydrological characteristics in Victoria, Australia. Their objective was to provide a hydrological framework where stream-ecologists could choose sample sites in order to examine the spatial and temporal distribution of biota. In addition, a regional hydrological framework enables the detection of representative rivers (or parts of rivers) for catchment conservation, although the scale of the ecological hypothesis must be compatible to the scale of regionalization.

This short review of the main regional ecohydrological studies clearly establishes the multiscale hydrological variability effects on physical aquatic habitat characteristics and regional scale ecological coherency. A cartographic assessment of instream physical habitat will aid the ecological management of streams and rivers, enabling important areas to be targeted. Instream biological characteristics sampled over a few years are judged to provide too variable data for statistical analysis. To overcome this constraint of limited long term regional instream biological data, stream-ecologists would instead like to use long term discharge records. To meet this objective better, data on hydrological-ecological linkages are currently required, although important progress in stream ecology could come from adequate knowledge of ecohydrological variables. A major current problem seems to be the definition of temporal and spatial scales of disturbance. For this reason disturbance definition is a polemical and fundamental question in community ecology (Poff, 1992; Resh *et al.*, 1988); as written by Poff: '*specification of disturbance is scale-dependant and is guided by the ecological question(s) of interest*'. Relevant ecohydrological variables must have identified roles on specific and key aquatic ecosystem subsets like stages of biological developments (Jowett & Richardson 1989). Another difficulty will be the definition of hydrological thresholds (Capra, *et al.*, 1995) which regulate aquatic community dynamics at a managed reach or at the human influenced scale. We have to consider that space and

time function together to shape lotic communities at scales ranging from short term/local to evolutionary/global (Minshall, 1988). To answer this question efforts must focus both on local and regional scale hydrological-biological linkage analysis. Local scale analysis will focus on functional relationships between physical habitat constraints and population dynamics using long term available records. A better definition of the fluvial morphology response to hydrological regime is needed using bankfull discharge concept and 'morphological flows' (Herouin *et al.*, 1995), in conjunction with physical macro-habitat model development (Lamouroux *et al.*, 1996). Development of ecohydrological variables is a challenge for hydrologists, river morphologists and stream-biologists.

2 A conceptual framework for definition of ecohydrological variables

New hydrological variables must be developed to describe flow conditions in terms of the limiting conditions which explain natural instream population dynamics. This means that hydrologists should consider some new theoretical aspects like resilience population capability and population robustness to flow disturbances. First research in this field (Blandin & Lamotte, 1985; Resh *et al.*, 1988; Ward & Stanford, 1983) led to a definition of frequency flow domains in relation to population dynamics (as shown in Figure 1).

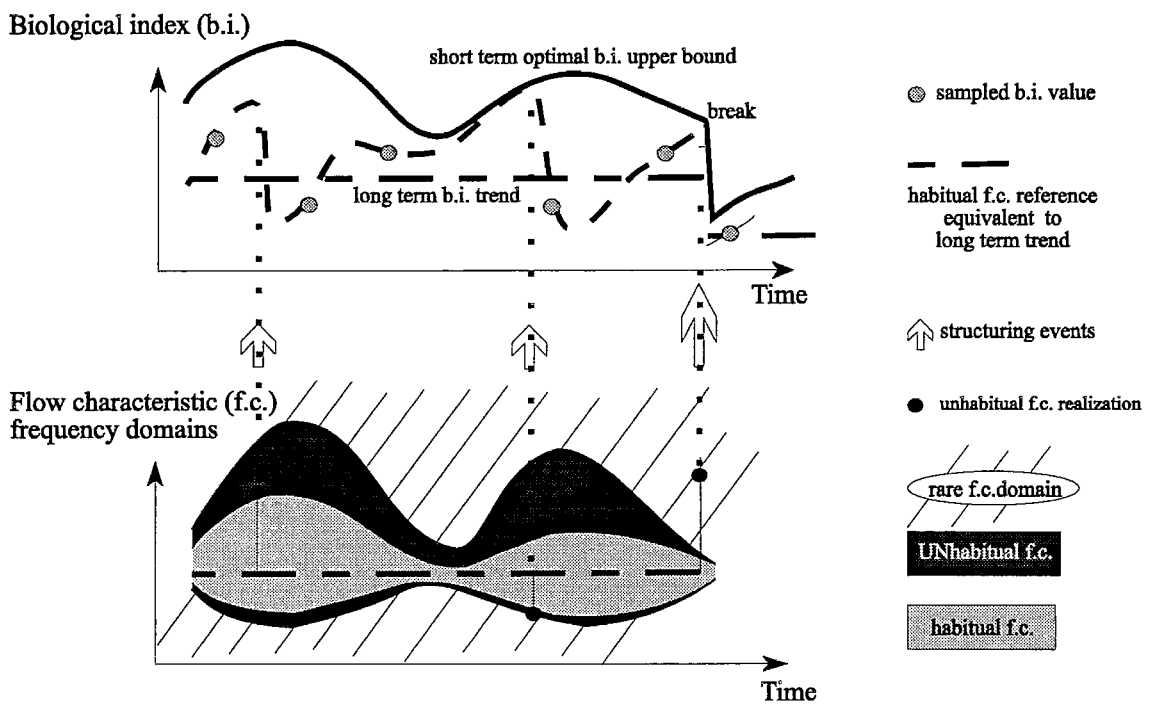

Figure 1 : A conceptual based biological-hydrological relationship to develop ecohydrological flow characteristics.

Figure 1 : Une conceptualisation des relations biologie-hydrologie qui appelle des caractérisations écohydrologiques de l'écoulement

It can be seen that the sampled biological index, like fish diversity or abundance by stage, are temporal observations which stream ecologists have to link in time (dashed line) using functional relationships with environmental conditions. Linkage of biological index fluctuations to flow conditions is supported by the overall agreement that frequent environmental conditions define the long term trend in aquatic community characteristics. A second assumption is that an optimal biological index reach capacity is time dependent on seasonal variations with a characteristic optimal short term capacity. The long term trend in biological index could be under such an optimal capacity, depending on the frequency of flow

characteristics. Flow characteristics have to be determined in a relevant manner for biological purposes. In natural conditions and without any disturbance effect, the aquatic community could grow freely up to its optimal reach capacity. Main ecological theories state that temporal flow variability could explain species richness and biomass along a reach of river and across reaches. One could wonder if the frequency of nonhabitual flow characteristics could explain why a biological index stays under its optimal capacity. In such a case, ecohydrological events could affect long term biological indices, depending on the resilience capacity limit and structuring of event frequency. In this figure we consider that nonhabitual but not rare events are structuring events in such a way as to induce a continuous dynamic ecosystem balance. In the case of a rare event, the balance could be broken as a result of a major river bed material transport by floods, for example. It is important to note that the temporal axis is not scaled, as it depends on the biological species of interest: fishes have an annual reproduction cycle with seasonal important steps and invertebrates could have monthly reproduction cycles. To refine the temporal axis scale, stream ecologists will have to produce a hierarchy of controlling and limiting factors for an overall (impacted) stream ecosystem. The main components have been widely discussed in the light of ecological theories.

Such a conceptual framework allows stream ecologists to check ecohydrological characteristics against biological data in time. The first task will be to define a set of ecohydrological characteristics to support regionalization approaches. The hydrologist would first have to verify how ecohydrological variables can distinguish between smooth and rough flow regimes which are known to be linked to quite different aquatic ecosystems. Such comparisons were conducted in a PhD project (Malafosse, 1996), in which a set of 55 stream gauges was selected in the Rhone basin and classified into seven categories from dominant ice-melt to strictly rainfall fed flow regimes.

Applying the principle in Figure 1, a frequent flow characteristic was determined from flow statistics. A moving average of thirty daily flows was retained observing that 60% of the discharge was grouped around it, and not more than 10% of variance for each hydrological regime. A new time series of daily flow characteristics, called $DQ(t)$ was then calculated, subtracting daily flows from the moving average. These new time series were assumed to represent 'continuous nonhabitual events time series' with regard to their actual frequent seasonal flow conditions. Absolute values were retained making the assumption that both positive and negative values could affect a supposed natural biological index. As the objective was to quantify a nonhabitual event with structuring effects probabilistic distributions of monthly seasonal maximum DQ were analysed, using a classical empirical distribution on a time axis expressed in terms of mean return period in yearly units. It was found that a two parameter exponential law provided a good fit to sampled distributions. Parameter (A) represents the slope of the exponential law and parameter (B) the one year mean return period DQ . A high value in parameter (A) means great variability for nonhabitual conditions and can be related to unpredictable situations in the season. In reverse, low values mean more predictable values for nonhabitual conditions in the season. A high value in parameter (B) means frequent conditions have a wide spectra and vice-versa. That kind of information could be related to the structuring effect on the lotic ecosystem. (A) and (B) parameters were checked against 16 more classically used statistical parameters to describe hydrological variability. A normalized principle component analysis (npca) revealed three groups with habitual conditions describing the first axis, nonhabitual conditions and skewness coefficients (sc) describing the second axis and intermediate position for coefficient of variation (cv). The first two axes accounted for 70% of the variance. Hence, considering that cv and sc were intermediate measures of habitual/nonhabitual conditions 8 parameters were finally retained. To avoid the influence of a variable number of stations of each flow regime, mean monthly parameter values by flow regime were calculated. Routing npca on mean values, led to the observation that parameters (A) and (B) make a clear distinction between habitual and nonhabitual flow characteristics and have high loadings respectively on axis 1 and 2, which accounted for 84% of the variance. Monthly seasons were then plotted in ordination space 1,2 (see Figure 2).

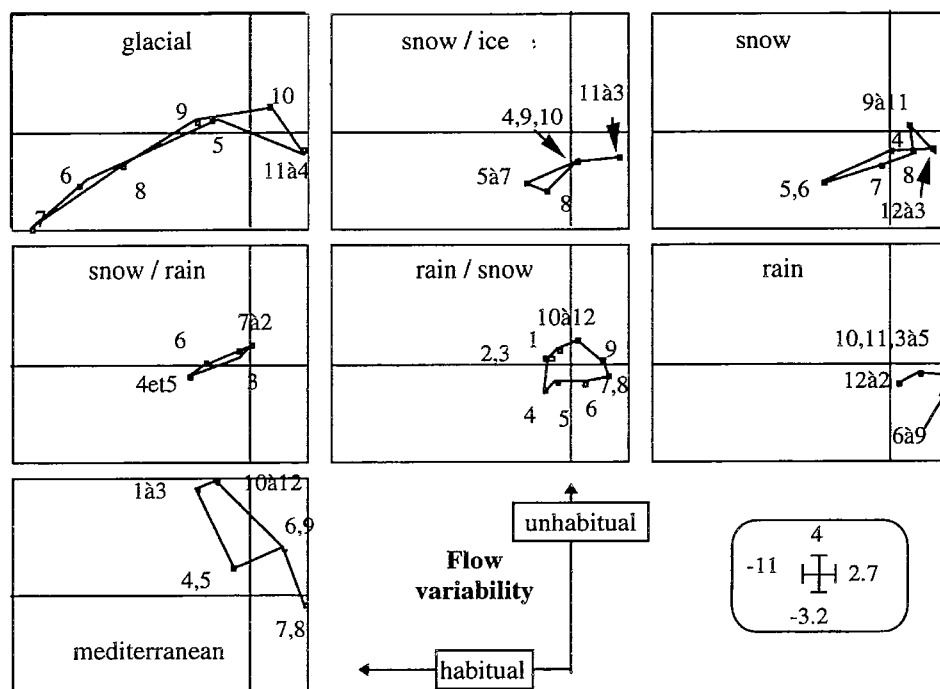

Figure 2 : Position of monthly seasons (1 to 12) for seven flow regimes into frequent and less frequent hydrological variability dimensions mainly represented by A and B parameters (Malafosse, 1996)
Figure 2 : Positionnement des 12 saisons mensuelles, pour 7 régimes, selon deux axes de variabilités (fréquente et peu fréquente), représentés par A et B (Malafosse, 1996)

Note that very different seasonal successions in flow variability, as defined in the conceptual framework (Figure 1), characterize each flow regime. A glacial fed flow regime presents low nonhabitual DQ values for months 6 to 8 and stays around mean values (normalized analysis) for the rest of the year. In reverse, the it presents highest range in habitual DQ values. In that sense the required seasonal conditions for biological activities are very predictable. A Mediterranean rain fed flow regime is highly unpredictable with a narrow range in habitual DQ and a high range in nonhabitual DQ. Using such a ‘disturbance framework’, a first rough regionalization was performed on the Loire basin (117000 km²) using GIS climatic and geological information. The objective is now to refine the spatial scale of this ecohydrological approach.

3 Operational perspectives

A sustainable development in surface flowing waters needs to assess trends and impacts of anthropogenic activities on aquatic communities. From a practical point of view, these activities could be considered as disturbance zones located at several points in the hydrographic network. Such disturbance sources must lie in acceptable ranges to ensure aquatic community dynamics. This is an operational objective because regional hydrology is often combined with local hydraulic works which impact a variable length of river. Another objective is to assess how flow variability could influence the aquatic community balance for river restoration or preservation. In that sense regional hydrology could provide a natural reference situation on regulated sites and in turn allow an impact assessment on the aquatic ecosystem.

Future directions for Northern European FRIEND

Orientations futures pour le projet FRIEND Europe du Nord

A. Gustard

The NE FRIEND project has seen rapid growth both in geographical extent and the acquisition of data since its inception in 1985. This section presents proposals for the future development of research, for each of the main project groups in turn.

Following the extension of the European Water Archive into central and eastern Europe there are several recommendations which would lead to improvements in the data for subsequent regional and modelling studies. It is recommended that the lengths of the series on the FRIEND database are extended to obtain a more homogeneous dataset in terms of a common period of record. Evidence of artificial influences in some of the national network series should be investigated, assisted by the use of automated screening procedures. The use of data from larger catchments will also provide longer time series for studies of temporal variability. For the sites in the resulting dataset, a complete coverage of consistent catchment characteristics across the entire region should be derived. This should include a range of thematic data held in vector or gridded form on a Geographical Information System. There is a need for consistent European data sets which should include hydrogeology, land use, digital river networks and digital elevation models. This would then enable consistent basin parameters and catchment modelling approaches to be applied across Europe.

There is a need for further research to improve the understanding of the interaction between hydrogeology and low flows. It is recommended that groundwater models are applied to a number of European catchments with contrasting climate, land use, soil type and hydrogeology using observed precipitation, evaporation, streamflow and estimated transmissivity and storativity. A subsequent sensitivity analysis would enable a better understanding of the dominant processes which influence the low flow regime of rivers in different climate and hydrological regions of Europe. Improvements in indexing the influence of storage characteristics (hydrogeology and lakes) on low flows is one of the main areas of research which will lead to improvements in relating low flows to basin properties and enable practical design techniques to be used with greater confidence. Further work needs to be done on defining indices of drought, describing the temporal variability of these indices and their spatial coherence. The estimation of drought frequency with a non stationary climate is also a high priority research area.

The flow regime classification needs further refinement to discriminate better between Atlantic and South European flow regime types. It will be necessary to use daily data - or at least some key statistics derived from daily data - and to explore further the use of statistical clustering tools. Second, the theoretical and practical issues posed by the use of objective methods for the interpolation of runoff along a river network need to be further addressed. This requires the development of digital river network and basin boundary data sets for a large part of the FRIEND project area. Third, the method for producing grid maps based on overlaying a grid on a mosaic map of catchment runoff needs to be refined and applied to seasonal and monthly data. It could also be used to present time series of monthly or seasonal data in order to portray the spatial evolution of, for example, a drought. There is also a clear need for investigations into the links between atmospheric circulation patterns and hydrological regimes. The work of FRIEND Project 3 has emphasised that both the spatial and temporal patterns in river flow regimes in Europe are dominated by climatic characteristics. Studies are needed into the linkages between particular atmospheric circulation conditions and hydrological response, and these can use either observed data or, with the application of macro-scale hydrological models, the output from numerical weather simulation models. The results from such studies will lead to an improved scientific understanding of hydrological variability, will help in the assessment of the

implications of atmospheric anomalies or climate change for European flow regimes, and may even lead to the development of seasonal river flow forecasts.

The flood studies in the FRIEND project focused initially on identifying and describing characteristic regional patterns in the flood regimes of North West Europe, with the index flood method as the basic analytical approach. The present project period has been devoted to the description and comparison of some of the different methods and approaches in development and use in the region. The logical continuation of the work is to systematically test and compare the methods on the regional data set. Such comparisons will throw more light on the strengths and weaknesses of the different methods, and would be an important step in the difficult process of establishing optimal methodologies for combining information from flood and rainfall series, catchment characteristics and regional information. The development of continuous simulation models for flood frequency estimation offers opportunities for improving the physical basis of flood estimation techniques and the ability to estimate the impact of environmental change on flood frequency distributions. Methods that combine all available information hold greater potential for the difficult task of reliable extrapolation of flood frequency curves to high return periods, and for flood estimation at ungauged sites.

To enhance process understanding of hydrological response, it is recommended that closer links are established between field workers and physical hydrologists and mathematical modellers. It is very important that contact be encouraged between those whose work is 'data-driven' and those whose approach is rather more conceptual. The development of models (and the correct interpretation of their results) requires a proper understanding of the physical processes operating in the system of interest. Similarly, there is little point in site-specific empirical studies without the development of conceptual (even if not mathematical) models of the processes operating and how they change and interact. Most process research in Europe has been based on investigation of impermeable catchments. With increased water resource demands in permeable lowlands there is a need to extend hydrological process research to investigate groundwater-surface water interaction. This will assist in the sustainable water resource development and environmental protection of river systems increasingly under threat from water resource development.

The future of Southern Africa FRIEND project

L'avenir du projet FRIEND Afrique Australe

S. H. Mkhandi

1 Introduction

The first phase of the FRIEND Southern Africa project came to an end in December 1996. This phase was concluded by publication of the end of project Final Report. The report presented research findings on the following research themes:

- Low flow studies
- Flood frequency analysis
- Rainfall-runoff modelling

In addition, the report presented a description of the data bases developed for Southern Africa and the summary of the hydrological and spatial data bases. After the successful completion of phase one, it is expected that the Southern Africa FRIEND project will continue into the second phase. This will allow consolidation of the research work already started. New research theme initiatives are also anticipated depending on the interests expressed by the participating countries. The direction of the future research activities for the Southern Africa FRIEND project will be made by the Steering Committee of the project and the following proposals represent the personal views of the author.

2 Research activities

Research activities during the next phase are likely to be developed along the following themes:

- Drought analysis
- Sediment transport
- Rainfall-runoff modelling
- Flood studies

These aim to solve some of the problems related to the assessment and management of water resources. The research themes on rainfall-runoff modelling and flood studies will be a continuation of research activities carried out during the previous phase. Drought analysis and sediment transport will be new research initiatives. The occurrence of frequent droughts in Southern Africa puts the efficient utilization of water resources under considerable constraints. The objective of the research on drought analysis therefore will be to develop suitable techniques to assess the severity of droughts. This will help in the more efficient management of the limited water resources in the event of a drought. Sediments seriously affect reservoir capacity. A research study to estimate sediment accumulation in reservoirs is important, taking into consideration that there are a lot of reservoirs constructed in the Southern Africa region.

3 Training

Apart from carrying out the research activities training of local personnel, aimed at capacity building in the region, will be an important task to be undertaken during the next phase. Lack of trained personnel hinders the processing, analysis and management of hydrological information in Southern Africa. Lack

of expertise in the field of research also hinders the development of hydrological research activities. In order to improve the situation in the region, there is an imminent need for developing appropriate capacity-building programmes. The methodology for achieving this will include providing short training courses at post graduate level or long term courses at M.Sc. or PhD levels.

The short training courses will most likely be organized by the FRIEND project under the research themes to be pursued. The emphasis in training during the second phase will probably concentrate on the following areas:

- Rainfall-runoff modelling
- Drought analysis
- Sediment analysis

In the light of the new techniques developed to assess water resources by using geographical information system (GIS), there will be a need to provide training on the application of GIS in water resources studies. The target group for the short training courses will be the Hydrologists/Water Resource Engineers that will be involved in the FRIEND project. Opportunities for the long term training courses (M.Sc. and PhD.) hopefully will be arranged with the training institutions available in the region, depending of course on the availability of funds for fellowships.

Hydrologie régionale et développement durable en Afrique de l'Ouest et Centrale

Regional hydrology and sustainable development in Western and Central Africa

E. Servat, J.M. Fritsch, A. Afouda

1 Introduction

Les programmes de recherche en *hydrologie régionale*, tels qu'ils sont menés aujourd'hui dans le cadre des différents programmes FRIEND africains occupent une position stratégique dans l'ensemble des recherches portant sur le cycle de l'eau sur ce continent. Au delà de l'acquisition de connaissances, ils visent explicitement au renforcement des capacités de recherche des institutions des pays du sud et au développement de produits transférables pour la planification et la gestion des ressources en eau. En effet, la prise en compte simultanée d'un cycle de l'eau "naturel" et d'un cycle de l'eau "anthropique" (caractérisé par des stockages, des modifications de régime des écoulements, des prélèvements, des rejets, des pollutions) apparaît clairement dans les grandes orientations des programmes d'hydrologie régionale en cours ou prévus :

- Identification et conséquences des fluctuations climatiques.
- Relation eau-environnement.
- Gestion régionale et intégrée des ressources en eau.
- Impacts des aménagements et planification des ressources en eau.

L'échelle régionale, qui considère le fonctionnement des systèmes hydrologiques et les usages des ressources en eau à l'échelle du bassin versant, parfois sur des ensembles transnationaux, correspond aux contraintes de la planification et de l'action, pour un continent caractérisé par l'existence de très grands systèmes fluviaux (Congo-Zaïre, Zambèze, Nil, Volta, Niger, Sénégal, etc.). Que ce soit sous forme de bases de données et de connaissances, de synthèses, de méthodologies ou d'outils logiciels, les "produits" de la recherche en *hydrologie régionale* devront apporter des éléments de réponse aux questions que posent l'estimation, la planification et la gestion des ressources en eau.

Ces considérations sont particulièrement pertinentes pour la zone Afrique de l'Ouest et Centrale, caractérisée par un secteur d'hydrologie opérationnelle relativement structuré au plan institutionnel mais en difficultés chroniques par suite de la conjoncture budgétaire, et par un secteur scientifique émergeant, encore très diffus, qui ne pourra atteindre une masse critique viable à moyen terme que dans le contexte d'une collaboration régionale. D'autre part, dans cette région où l'accès à l'eau reste encore problématique, que ce soit au niveau individuel (domestique) ou au niveau des infrastructures du développement économique, la Recherche hydrologique doit montrer aux acteurs du développement que ses représentants les plus brillants veulent s'impliquer fortement dans ces problèmes de ressources en eau et mettre leur énergie et leurs capacités au service de cette cause. Le projet FRIEND AOC se donne pour objectif de jouer un rôle moteur et d'apporter une contribution significative dans cette voie.

Dans cette région d'Afrique, d'importantes études ont déjà été conduites avec pour objectif la connaissance de la variabilité spatiale et temporelle des régimes hydrologiques à partir d'ensembles de données régionales. Cette caractérisation du régime des écoulements, associée à la modélisation de phénomènes tels que les relations "pluie-débit", constitue le fondement des projets FRIEND du PHI de l'UNESCO. Ces études doivent cependant être revisitées et complétées, les conditions hydrologiques ayant considérablement évolué sur la plupart des bassins de la zone AOC, que ce soit à cause de la variabilité climatique ou par suite de l'action anthropique. Cette réactualisation, envisagée dans le cadre

de FRIEND AOC permettra une plus juste estimation des ressources en eau, avec éventuellement une modification des normes hydrologiques en usage dans la région, facteur de succès et de pertinence de tout programme de développement en relation avec l'usage de l'eau.

Pour être en mesure de réaliser ces projets, les groupes de recherche impliqués en Hydrologie régionale doivent pouvoir s'appuyer sur un ensemble d'informations, exhaustif et de qualité. Ceci concerne les banques de données constituées par les *séries chronologiques* de différentes variables hydroclimatologiques. La banque hydropluviométrique du programme FRIEND AOC déjà constituée devra donc être développée, en y intégrant d'autres variables de type climatologique ou relatives à la qualité des eaux. D'autre part un effort particulier devra être fait pour faciliter l'agrégation et la manipulation de données de type géographique (tracé des réseaux hydrographiques, géologie, pédologie, végétation, occupation des sols, répartition et densité de population, etc.). Il s'agit d'un travail important et prioritaire pour lequel des collaborations étroites seront établies avec d'autres projets FRIEND, particulièrement le projet FRIEND Afrique Australe. La banque de séries chronologiques, couplée avec les S.I.G. qui viennent d'être évoqués, constituera le support pour la mise au point et la diffusion de différents outils de simulation et d'aide à la décision.

Depuis la réunion de Cotonou en décembre 1995, six thèmes existent dans le cadre de FRIEND AOC, outre le thème "Banque de données". Leurs niveaux d'activité sont cependant inégaux et dans les années à venir un des objectifs sera de promouvoir et de soutenir les recherches menées par les groupes thématiques les plus récemment constitués ou qui ont éprouvé le plus de difficultés à se mettre en place. Hormis les thèmes classiques des projets FRIEND tels que "modélisation pluie-débit", "régionalisation des paramètres hydrologiques" ou encore "étiages", trois thèmes du programme AOC touchent spécifiquement au domaine des ressources en eau et en abordent la "qualité", la "variabilité" et la "gestion intégrée". Ces thèmes constituent une des spécificités du programme. Ils recoupent certaines préoccupations de la communauté scientifique internationale et sont de nature à susciter l'intérêt des acteurs du développement des pays de la région et des bailleurs de fonds. Il est donc à la fois souhaitable et prévisible que ces pôles thématiques soient appelés à se développer très significativement dans l'avenir.

Le projet FRIEND AOC, outre ses objectifs de recherche, doit jouer un rôle important de catalyseur et de soutien vis à vis de la communauté des scientifiques d'Afrique de l'Ouest et Centrale, en concertation avec les organisations internationales, régionales et les programmes de coopération bilatérale. A cette fin, plusieurs résolutions ont été prises dans le domaine de l'animation scientifique et dans celui de la formation. Il est acquis que ce projet permettra aux universitaires et aux chercheurs africains de se rencontrer régulièrement. C'est dans cette optique que seront organisés chaque année des ateliers scientifiques, tels que celui de Cotonou (décembre 1995). La participation à des conférences internationales est également un objectif retenu pour lequel des moyens financiers devront être recherchés. Dans le domaine de la formation, des sessions organisées chaque année sur divers aspects thématiques ou méthodologiques, permettront aux participants de compléter leurs connaissances dans leurs domaines de recherches respectifs. Ces actions très concrètes d'animation et de formation contribueront notablement à la visibilité et au renforcement des communautés scientifiques de la région AOC. Certaines de ces sessions pourront être organisées en concertation avec l'AISH ou l'AHA (*Association des Hydrologues Africains*).

Enfin, les relations déjà initiées avec les autres Groupes FRIEND seront renforcées. Au plan institutionnel, les équipes et le comité de pilotage de FRIEND AOC pourront bénéficier de l'expérience de la pratique d'un mode de fonctionnement du réseau scientifique FRIEND. Certains thèmes de recherche tels que "Modélisation pluie-débit" ou "Etiages" feront l'objet de travaux interconnectés avec les autres Groupes FRIEND africains (Afrique Australe et Nil), avec l'intérêt que l'on devine tant au plan des échanges méthodologiques qu'à celui de résultats obtenus à partir d'une base d'informations continentales.

Prevention and management of environmental hazards in the Hindu Kush-Himalayas - HKH FRIEND

Prévention et gestion des risques environnementaux dans le Groupe Hindu Kush-Himalayas de FRIEND

S.R. Chalise

1 Background

Extending about 3500 km from Afghanistan in the west to Myanmar in the east, the Hindu Kush-Himalayas (HKH) are home for nearly 120 million people who influence the life of more than three times as many people living in the downstream basins and plains. As the largest storehouse of fresh water in the lower latitude, these tallest mountains and the Tibetan plateau are important water towers for nearly 500 million people on this earth and are the sources of such mighty rivers as the Indus, the Ganga, the Yarlung-Tsangpo, the Brahmaputra, the Nu-Salween and the Mekong.

The Hindu Kush-Himalayas, as the youngest mountains, are also tectonically very active and hence inherently vulnerable to hazards. In addition, these mountains are exposed to intense seasonal precipitation annually during the four months (June-September) of summer monsoon, particularly in the eastern parts, which acts as a trigger for various types of natural hazards in different elevation zones. If snow avalanches and glacial lake outburst floods (GLOFs) predominate at very high elevations (> 3500 m), then landslides, debris flow and flash floods are common in the middle mountains (500-3500 m), and floods are the principle hazards in the lower valleys and plains. The combination of inherently weak geology and intense precipitation which characterizes these mountains make it extremely vulnerable to hazards even in normal climatic conditions. During extreme weather events the consequences are disastrous. Hundreds of lives and billion of dollars worth of properties and investments in high cost infrastructures are lost in the region every year due to landslides, debris flow and floods along with the destruction of scarce agricultural lands. For example, in China landslides alone are estimated to cost 15 billion US \$ in economic losses and 150 deaths annually (Li, 1996) and in Nepal landslides and flood hazards cause destruction of important infrastructures worth US \$ 2.5 million and about 400 deaths annually (Khanal, 1996).

Despite the fact that climate and hydrology are the principal causes as well as contributing factors for natural hazards in the HKH, scientific research in these have not received enough attention. This is primarily because the establishment of reliable monitoring systems to collect data on climate and hydrology is not easy and involves very high cost in these high mountains with poor accessibility. In addition to these physical difficulties and the huge costs, which are not easily affordable to the countries of the region, hydrometeorological services and research in the HKH mountains have also a short history in many countries of the region. (Afghanistan is an extreme case where the civil war has virtually destroyed the hydrological and meteorological stations). Although hydrological and climatic data for operational and forecasting purposes is regularly collected in many countries of the region, the sharing of such data for research is virtually non-existent.

2 Hazards and uncertainties

Much of the discussion regarding environmental degradation in the HKH which started in mid-70's (Eckholm, 1975 and 1976) has focused primarily on ecological concerns, particularly on deforestation caused by the fast growing human and animal population and its impact on local and regional ecology and economy, particularly concerning erosion and sedimentation. Since then the bulk of the research

work, whether field-based or based on available data, has been primarily concerned and focused in ascertaining in quantifiable terms the relative role, impact and contributions of human and natural processes in causing environmental degradation in the region. However, it is seen that with the existing and available data and evidence, it is difficult to quantify the relative contribution of Man and Nature in environmental degradation of the HKH and much of the 'uncertainty' and 'dilemma' originate due to the absence of long term and reliable data which could be used to understand the governing processes at micro-, meso-, and macro-scales (Ives and Messerli, 1989). A recent study has shown that human processes are more important for micro-basins whereas natural processes predominate in macro-basins, and without a fuller understanding of the processes occurring at the meso-scale and the linkages between these processes on different scales, it is not possible to be certain of the roles of Man and Nature (Grosjean *et al.*, 1995).

These preoccupations with the roles of Man and Nature have somewhat overshadowed the fact that the HKH environment is not only inherently (geologically) fragile but also subjected to two powerful triggering factors - earthquakes and climate. Of these climate affects regularly, and more intensely, during extreme weather events which are found to occur more frequently. Therefore, the long-term average annual loss of life and property due to floods and landslides associated with abnormal weather conditions becomes significantly high as compared to the loss from earthquakes. Although extreme weather events could be associated within the normal fluctuations of climate, it is important to ascertain whether or not the increasing frequency of extreme weather events in the HKH are within these normal fluctuations. Again, despite uncertainties, potential impacts of global warming which could affect the HKH region include increased monsoon rainfall, enhanced precipitation and shrinking of areas under snow and permafrost (Chalise, 1994). The implications are therefore towards an increase in hazardous events, particularly in the hydrological aspects since both accumulation and ablation of snow occur in the summer in the HKH. In any case, it is obvious that both the inherent and triggering factors contribute towards the hazardous nature of the HKH environment and the incidences of natural disasters are likely to increase rather than decrease.

3 Hydrology and sustainable development in the HKH

There is yet another important aspect of water management in the HKH which needs to be emphasized. Water is not only a principal contributory factor for environmental hazards. It is also a critical resource not only because of its rapidly growing demand due to rural, urban and industrial development in the HKH, but also because it is the single most important resource which if harnessed properly could generate enormous power, control floods and irrigate millions of hectares of land and could radically transform the economy of the region towards prosperity for all (Verghese, 1990).

Although water has also been a contentious issue in the region in the past, more recently there have been important and encouraging agreements between different countries in the region in the sharing and development of water resources for mutual benefit. The theoretical power potential of the region exceeds 310,000 MW and even smaller countries like Bhutan and Nepal are considered to possess hydropower potential of 20,000 MW and 83,000 MW respectively (Chalise *et al.*, 1994). These estimates will be much greater if all the potential sites for mini and microhydro sites could be assessed. Hence high expectations from water are not unnatural. However, sustainable harnessing of such enormous potential requires adequate scientific understanding of the hydrology of the region which will also help develop regional cooperation in the management and optimal utilization of water resources for multifarious benefits on scientifically sound and objectively realistic terms. Although reliable rainfall data, even for the past 50 years, are generally not available for many areas of the HKH region, it is seen that smaller watersheds or subwatersheds (<50 km²) are more affected than the bigger ones by disasters caused by flash floods and debris flow triggered by intense rainfalls associated with extreme weather events, as was seen in Central Nepal during July, 1993 (Dhital *et al.*, 1993) and in eastern Nepal during July and August 1996 (ICIMOD, 1996, DPTC, 1996). It has also been seen that new settlements, which are often located on old landslide deposits or the debris fan in such small

watersheds, close to the recently constructed roads, are the worst affected by flash floods and debris flow. Again, hydrological monitoring and measurements in such watersheds are difficult particularly because big boulders often roll down the rivers and streams and can damage or destroy hydrological monitoring and measuring stations during the monsoon. In addition, the river beds are normally unstable due to very high volume of sediments discharged from upstream mountain slopes. These problems demand innovative and intensive hydrological monitoring systems in the HKH mountains. Smaller watersheds are also often inhabited by poor and marginalised farmers who have to live with the local environmental hazards. Adequate understanding of the hydrology of such watersheds will be a first step towards helping such vulnerable people.

From the foregoing discussion it is obvious that management of environmental hazards essentially depends on management of water. Similarly, management of water is also critical for utilizing the huge potential of water for power, irrigation and rural, urban and industrial supply for sustainable economic development of the region. Adequate understanding of hydrology of the region is therefore the starting point to developing a sustainable operational system for the management of water for its multifarious use in the region.

4 Regional cooperation on hydrological research and the HKH-FRIEND project

A hazardous combination of weak geology, intense monsoon precipitation and high relief within short distances has also hindered the growth of knowledge and understanding of the hydrology of the region. Again transfer of hydrological models and techniques of measurement developed in the temperate region for use in the HKH mountains is difficult and could also be inappropriate. Hence, development of adequate understanding of hydrology of the HKH mountains depends very much on studies carried out in the region itself. Such studies must be based on reliable and adequate data on hydrology, meteorology and other relevant parameters. Thus generation of such reliable data and sharing of such data among the researchers of the region are of fundamental importance.

For various reasons outlined above, hydrological research in the region has either a weak base or is carried out in isolation. Modern techniques and methods and instruments used for hydrological studies are also not within the reach of researchers in hydrology. Thus development of human capacity is a must and should be the first step to embark on the challenging task of developing adequate knowledge of hydrology to solve the problems of management of environmental hazards and optimal and sustainable development of the rich water resources of the HKH region.

The HKH-FRIEND, which was launched during the Regional Workshop in March 1996 (Chalise & Khanal, 1996), has already been endorsed officially by six of the eight countries of the region. It is expected that it will be endorsed by all the countries of the region soon. UNESCO and ICIMOD have been collaborating jointly with all the regional countries and the WMO since the very beginning to extend the FRIEND concept to this region and to develop a regional hydrological research programme for the HKH.

As it has evolved through a series of regional consultations within the framework of UNESCO's International Hydrological Programme (IHP) since December 1989, it is based on the real needs of researchers of hydrology in the region. Its priorities have also evolved accordingly. It is therefore expected to provide an active forum and institutional base for intensifying hydrological research through exchange and sharing of knowledge, experience and data among researchers in the region.

The principal tasks ahead are to develop a data base and to enhance human capacity in the region for undertaking hydrological research through appropriate training programmes. Considering the extreme vulnerability of small watersheds, it would be appropriate to focus research on such watersheds in diverse climatic and altitudinal settings and develop a regional data base on participating watersheds. Watersheds which are presently under study and have monitoring systems should be considered instead

of new watersheds for this research network.

For all who are, and will be, associated with the HKH-FRIEND it is encouraging that apart from the existing close collaboration between regional countries, UNESCO, ICIMOD and WMO, active support for this project has also been received and is expected to continue from the German IHP/OHP Committee, the Global Run-off Data Centre (GRDC), the Institute of Hydrology, UK and the Slovak IHP Committee. The challenges of preventing and managing environmental hazards and sustainable development and management of water resources in the HKH are enormous and complex but a beginning has been made by launching the HKH-FRIEND.

Short conclusion

Brève conclusion

P. Givone, A. Gustard, G. Oberlin

Even a sceptic reader, who knows only too well the difference between intention and actual achievements, must acknowledge that the developments expected within FRIEND are impressive. They are both mature and feasible. There is an underlying fear however: is society yet motivated to move away from the present short-term and frequently irresponsible management of water resources to a more reliable long term approach, focusing on more sustainable development with greater equality between populations exploiting water and those who must bear induced risks?

The first contribution (Oberlin *et al.*) shows clearly that the old, but rarely taken up, idea of developing water bodies in the opposite direction to traditional channelisation, seems now to have a real future, and could progressively overcome the weakness mentioned above. From this recent evolution has arisen the 'golden rule' named "dynamic slowing down of water". This rule now seems to be correctly understood, and is being taken into account by an increasing number of water managers and decision-makers. Several conditions have made this possible: among them, many relate to FRIEND, either through past contributions or through its original targets and perspectives. Among the former, the progress made in synthesis modelling (floods, low flows, mapping available resources, etc.) at a large range of scales, were key achievements.

The second contribution (Gilard) details another achievement also necessary for implementation of the 'golden rule'. This was the hydrological quantification of the societal and economic vulnerability to flood waters, a key interface between hydrology and society. Here also, the contribution made by regional hydrology was essential, especially the so-called xdf models (where x is a hydrological time series variable, generally a threshold). The development prospects are particularly encouraging in this area, with the techniques already having been tested for biological populations in connection with minimum water requirements and also protection against excess water (Coudert, 1996).

Such an approach is also evident in the third contribution (by Breil *et al.*) which presents an example of some ecohydrological approaches developed recently by some FRIEND teams (particularly the NEF and AMHY groups). These show that some of the new micro-habitat models such as PHABSIM, EVAH, etc. have given low priority to the hydrological conditions which influence the structure of biological populations and the global quality of water bodies. One reason for such a gap is that until now no relevant regime or synthesis models existed within hydrology.

The fourth contribution (by Gustard) concerns the future of the NEF group and clearly shows the relevant advantages brought about by time and experience. Here the proposed actions are based on both previous successes and recognised deficiencies, with the targets now identified likely to deliver on the basis of data already available. It is useful to recall here the relevant programmes:

- consolidation of data sets in time and space (EWA);
- relating low flow response to hydrogeology and evaluating the growth and decay of droughts and long term trends;
- the contributions made on regime concepts including scale problems, modelling and links with basin and climate characteristics;
- improvements in rare and extreme flood estimation;

and finally, continuing the struggle to bring process and regional hydrologists closer, to allow a better physical interpretation of regional features and for the physical modellers to take better account of large scale effects.

The fifth contribution (Mkhandi) shows that, even for a 'junior' FRIEND group such as SADC, it is possible to have new ambitions. Due primarily to the regional conditions of SADC, the group aims to focus on three aspects: droughts, sediment transport and large regional scale training for hydrologists and for hydrological services.

The sixth contribution (Servat *et al.*) recalls, in a mature and impressive way, the large initial ambition of this young AOC group. Covering all hydrological topics, including persistent trend problems of both anthropogenic and natural origin, this group proposes to integrate water management features from the very beginning, despite a relative paucity of scientific hydrologists. The AOC group aims to develop such scientific capacities and will be managed, together with the young association of African hydrologists, and will establish links with two other African groups, SADC and Nile.

The last contribution (Chalise) is an example of an initial and future FRIEND programme built around a strong environmental objective, within a perspective of sustainable development, as is expected in the HKH group. Such an ambitious objective derives not only from local regional considerations but also from inter-regional liabilities and stakes: the HKH region is a 'water tower' for — in the very near future — probably more than a thousand million people. Among the large range of scientific topics induced by such integrated targets, the trigger conditions which can induce extreme hydrological (or water linked) hazards must be taken into consideration, not only for the hazards themselves (floods, erosion, land slides, etc.) but also for their long term consequences on water resources. The very specific conditions consequent upon monsoon, high altitudes, steep slopes and unstable geology will require much innovation and close cooperation with other FRIEND groups.

This brief review of future directions for FRIEND are very encouraging, both for the actors (the hydrologists) and for the potential users (the water managers); such directions have the full agreement of Unesco's International Hydrological Programme. The problem now is: will such ambitious targets inspire and motivate a sufficient number of research funding agencies, universities, research institutes and operational agencies to enable the high level of expectations to be realised ?

The answer to this question will be found in the next century, with the publication of the fourth FRIEND General Report in the year 2001.

oooo

Même un lecteur sceptique, qui filtrerait le contenu de ce chapitre en y appliquant un net *distingo* entre ses prévisions et les réalisations futures, devrait reconnaître que les développements attendus dans FRIEND sont relativement impressionnants. Ils apparaissent également bien mûris, et raisonnablement faisables. Une crainte est cependant sous-jacente : la société est-elle réellement motivée pour passer, dans sa gestion des eaux et de leurs milieux, de ses comportements actuels souvent à court terme et peu responsables, à des comportements plus responsables, visant un développement plus durable, et servant une meilleure équité entre les populations exploitant les eaux ou subissant les risques induits ?

La première contribution (Oberlin *et al.*) montre clairement que l'idée déjà ancienne, mais rarement mise en oeuvre, de renverser la vapeur et de réaménager les milieux aquatiques dans un sens quasi-opposé aux us et coutumes des recalibrages, semble enfin avoir un réel avenir, ce qui signifie aussi qu'on corrigerait progressivement la faiblesse mentionnée ci-dessus. Cette évolution récente a permis de faire émerger une règle d'or dite du "Ralentissement dynamique des eaux". Cette règle paraît être déjà correctement comprise, et même progressivement prise en considération par un nombre croissant d'aménageurs et de décideurs. Plusieurs conditions ont récemment permis cette évolution positive. Certaines concernent FRIEND, soit via ses travaux réalisés, soit via ses objectifs de base et ses perspectives. Parmi les premiers, les progrès faits en modélisation de synthèse (crues, étiages, cartographie des ressources disponibles), et leurs larges validités d'échelles, ont été cruciaux.

La seconde contribution (Gilard) détaille un autre aspect nouveau, entre autres nécessaire pour la mise en oeuvre de la règle d'or précédente. A travers une quantification en termes hydrologiques des vulnérabilités socio-économiques aux eaux inondantes, le fossé qui a toujours existé entre les besoins

de la société et les connaissances hydrologiques peut être à présent efficacement comblé. C'est probablement un point-clé pour articuler objectivement, et de manière objective et négociable, l'hydrologie sur la société. Là aussi, les contributions de l'hydrologie régionale, et plus particulièrement les modèles de synthèse dits en xDF (où x est une variable hydrologique temporelle, généralement de type seuil), sont essentiels sinon indispensables. Les perspectives de développement sont tellement encourageantes, que ces approches hydrologiques d'une demande externe ont déjà été testées pour les besoins des populations hydrobiologiques, y compris pour ce qui est de leurs besoins minimaux en eaux, et pas seulement de leurs besoins de protection vis à vis des eaux en excès (Coudert, 1996).

Cette extension est également liée à celle présentée dans la troisième contribution (Breil) qui présente un exemple d'approche écohydrologique récemment développée autour de certaines équipes FRIEND (essentiellement les Groupes NEF et AMHY). L'origine de ce nouveau développement, donc non encore formellement programmé mais qui pourrait représenter un des futurs de FRIEND, est le suivant : comme pour les besoins de la société, les besoins biologiques (ceux de leurs populations) ont déjà suscité le développement de nouveaux modèles, par exemple ceux dits de micro-habitats (PHABSIM, EVAH, ...), mais ces développements ont plus ou moins ignoré les régimes hydrologiques qui structurent eux aussi les populations biologiques et la qualité globale des milieux aquatiques. Un des motifs de cette lacune est probablement l'absence antérieure, dans les sciences hydrologiques elles-mêmes, de modèles adéquats et synthétiques pour les régimes subis.

Dans la quatrième contribution (Gustard) qui traite du futur du Groupe NEF, apparaissent clairement les avantages significatifs qu'apportent le temps et l'expérience. Pour ce Groupe générique de FRIEND, les actions prospectives peuvent solidement s'appuyer sur les expériences antérieures, tant les réussites que les échecs, et des cibles ainsi mûries permettent de compléter efficacement les résultats déjà disponibles. Il peut être utile à tous de rappeler ici un programme aussi pertinent : consolider la base de données (EWA) dans le temps et dans l'espace ; interfacer les caractéristiques d'étiages avec celles du sous-sol (hydrogéologie) et exploiter le tout pour les concepts de sécheresses étendues et leurs éventuelles tendances ; contribuer, de diverses manières, à rebâtir les concepts de régimes, leur typologie, leur modélisation, et leurs liens avec les caractéristiques climatiques et de bassin, éventuelles tendances incluses ; améliorer les estimations de crues rares et extrêmes par des comparaisons de modèles menées de manière plus rigoureuse et forte ; poursuivre l'effort de longue haleine devant rapprocher l'hydrologie des processus de l'hydrologie régionale, avec l'ambition de disposer d'une meilleure interprétation physique des caractéristiques régionales, mais aussi de faire mieux prendre en compte les effets d'échelles par les modèles à bases physiques.

La cinquième contribution (Mkhandi) montre que, même pour un Groupe relativement jeune comme SADC, et sans négliger pour autant le suivi des thèmes initiaux (premiers résultats diffusés en 1996), il est possible d'avoir rapidement de nouvelles ambitions. Dans le cadre des conditions régionales de SADC, le futur essayera de viser trois buts principaux. Deux sont thématiques, en partie liés, et aussi quelque peu synthétiques vis à vis de thèmes plus classiques : sécheresses et transports solides. Le troisième était présent dans les premiers termes de référence de FRIEND ou du PHI, mais quelque peu négligé par les premiers Groupes européens, et il est encourageant d'observer que les Groupes jeunes peuvent développer FRIEND en dehors du seul point de vue de l'extension géographique qu'ils apportent : il s'agit d'exploiter les thèmes scientifiques pour assurer une formation à l'échelle régionale, tant des hydrologues que des services hydrologiques.

La sixième contribution (Servat et al.) rappelle, de manière particulièrement convaincante, les larges ambitions du très jeune Groupe AOC. Recouvrant la plupart des thèmes hydrologiques, et prenant systématiquement en compte les tendances lourdes et pérennes observées (tant celles d'origine anthropique que climatique), le présent et le futur du programme de ce Groupe tente aussi d'intégrer, et dès l'origine, des considérations de gestion des eaux. En sus des motivations scientifiques de base pour assurer d'emblée une telle intégration, il y a une spécificité régionale : la région AOC présente à la fois une structure de gestion des eaux historiquement établie de longue date, et une relative faiblesse des effectifs en hydrologie scientifique. Ce Groupe AOC est donc une occasion de développer les compétences scientifiques, et ceci va être assuré en liaison étroite avec la toute nouvelle Association

des hydrologues africains, et en tissant des liens avec les deux autres Groupes africains de FRIEND, SADC et Nil.

La dernière contribution (Chalise) est un exemple de programme présent et futur construit autour d'un solide objectif environnemental, et dans une perspective de développement durable, comme cela est envisagé dans la région du Groupe HKH. Une telle ambition n'est pas seulement issue de considérations locales et régionales, mais aussi de l'exercice d'une responsabilité inter-régionale et d'enjeux associés : la région HKH est le château d'eau pour une population qui dans un proche futur peut atteindre le milliard d'individus. Parmi le large spectre de thèmes scientifiques induits par un objectif aussi intégré, les conditions de déclenchement des aléas hydrologiques (ou de ceux liés à l'eau) doivent être bien pris en compte, non pas seulement pour les aléas eux-mêmes (crues, érosions, glissements de terrain, ...), mais aussi pour leurs conséquences à long terme, comme celles sur les ressources en eaux, ou sur les milieux aquatiques, ou sur la qualité des bassins versants. En sus, par suite de conditions régionales très spécifiques (moussons, très hautes altitudes, fortes pentes, terrains peu solides, ...), d'autres nombreuses innovations seront nécessaires dans ce Groupe, et son avenir prendra donc un chemin sans doute assez différent de celui pratiqué jusqu'à présent dans les Groupes FRIEND.

Comme indiqué en introduction, cette rapide revue de quelques perspectives envisagées ou déjà programmées dans FRIEND est fort encourageante, tant pour ses acteurs (les hydrologues) que pour ses utilisateurs potentiels (les gestionnaires des eaux et leurs autorités), et ceci en bonne cohérence avec le PHI et avec nombre d'enjeux du prochain siècle. Le problème est maintenant celui-ci : un potentiel aussi élevé va-t-il mobiliser un nombre suffisant d'agences de financement et d'autorités de la recherche, pour permettre un niveau également élevé de soutiens effectifs, conduisant à un nombre suffisamment élevé de réalisations effectives, en accord avec les espoirs soulevés ?

Les réponses à ces questions seront données, entre autres, au prochain siècle, dans le quatrième Rapport général quadriennal de FRIEND (2001).

References of chapter 8

Références bibliographiques du chapitre 8

- Blandin P., Lamotte M. (1985) : Ecologie des systèmes : fondement théoriques et principes méthodologiques in Fondements régionaux de l'aménagement d'un territoire, Masson Ed, 149-154.
- Capra H., Breil P., Souchon Y. (1995) : A new tool to interpret magnitude and duration of fish habitat variations. Regulated Rivers: Research and Management, Vol. 10, pp. 291-289.
- Cemagref HHLY (1996), Guide pratique de la méthode Inondabilité, à paraître avec le concours de l'interagences de l'Eau, 1996.
- Chalise S. R., Khanal N.R. (1996) : Hydrology of the Hindu Kush-Himalayas, Report of a Regional Workshop, March 23-24, 1996, Kathmandu, UNESCO / ICIMOD, Kathmandu.
- Chalise S.R., Pei S., Bhatta B., Shah P.B., Denholm J. (1994) : Natural Resources Management in a Mountain Environment, Proceedings of the tenth Anniversary Symposium of ICIMOD, Part B(d) December 1-2, 1993, ICIMOD, Kathmandu.
- Chalise S. R. (1994) : Mountain Environments and Climate Change in the Hindu Kush Himalayas, in Beniston, M. (ed.) Mountain Environments in Changing Climates. Routeledge, London and New York: pp 382-404.
- Chastan B. , Gilard O. , Givone P. , Oberlin G. (1995) La prise en compte du risque d'inondation, Ingénieries - FAT, n°2, juin 1995, 13-20
- Colwell R.K. (1974) : Predictability, constancy, and contingency of periodic phenomena. Ecology, 55, 1148-1153.
- Connell J.H. (1978) : Diversity in tropical rainforests and coral reefs. Science 199 : 1302-1310.
- Coudert C. (1996) : Inond'habitats. Applicabilité des concepts du modèle INONDABILITE aux milieux aquatiques et à leurs besoins en eaux. Mémoire de DEA, Paris (Engref et Paris VI) et Strasbourg (Enges), 64 p
- De Laney T.A. (1995) : Benefits to downstream flood attenuation and water quality as a result of constructed wetlands in agricultural landscapes. J. of Soil and Water Conservation, p.620-626.
- Desbos E. (1995) : Qualification de la vulnérabilité du territoire face aux inondations. Mémoire de DEA, Cemagref Lyon et INSA Lyon (Laboratoire Méthodes), 70 p.
- Dhital M. R., Khanal N. K., Thapa B. (1993) : The Role of Extreme Weather Events, Mass Movements, and Land Use Changes in Increasing Natural Hazards. A Report of the Preliminary Field Assessment and Workshop on Causes of the Recent Damage Incurred in South-Central Nepal (July 19-20, 1993). ICIMOD, Kathmandu.
- DPTC (1996) : Preliminary Field Survey Report on Disaster at Sunkhani VDC, Dolakha (25th July, 1996), Kathmandu.
- Eckholm E. (1975) : The Deterioration of Mountain Environment, Science, pp. 764-70.
- Eckholm E. (1976) : Losing Ground, World Watch Institute, W.W. Norton & Co., New York.
- Galéa G., Prudhomme C., (1993) Characterization of ungauged basins floods behaviour by upstreaming QdF mortels, 2nd international conference on FRIEND, 11-15 October 1993, Technische Universität Braunschweig, RFA, IAHS Publication, n°221 229-240.
- Gautier J.-N. (1991), INONDABILITE, cartographie de synthèse, Rapport X° Plan Etat-Région Rhône-Alpes, risque naturels en montagne, crues et inondations en vallée, 1991, 100 p.
- Gilard O. (1996), Flood risk management : risk cartography for objective negotiations, Third IHP/IAHS George Kovacs Colloquium, UNESCO, Paris, 19-21 sept. 1996.
- Gilard O., Givone P. (1996) : Flood risk management : new concepts and methods for objective negociations. In Destructive Water Conference proceedings, Anaheim California, June, 13 p.
- Grosjean M., Hofer T., Liechti R., Messerli B., Weingartner R., Zumstein S. (1995) : Sediments and Soils in the Floodplain of Bangladesh: Looking up to the Himalayas? in Schreier, H., P. B. Shah and S. Brown(eds.) Challenges in Mountain Resource Management in Nepal. Processes, Trends and Dynamics in Middle Mountain Watersheds. Workshop Proceedings, April 10-12, 1995, ICIMOD/IDRC/UBC, Kathmandu. Kathmandu/Vancouver pp 25-32.
- Herouin E., Breil P., Albert M.B. (1995) : Quelles approches pour synthétiser le fonctionnement physique des écosystèmes d'eaux courantes? Bull. Français de la pêche et le la pisciculture. Colloque habitat-poissons. No. 337, 338, 141-148.
- Heydarzadeh M. (1996) : Evolution des modèles hydrologiques de synthèse QdF en cas d'échanges Nappes/Rivières actifs et activables. Thèse de doctorat de l'Université Joseph Fourier, Mécanique et Géophysique, Grenoble.

- Hildrew A.G., Townsend C.R. (1987) : Organization in freshwater communities. In : Gee JHR, Giller PS (eds) Organization of communities past and present. Blackwell Scientific, Oxford, pp347-372.
- Horwitz R.J (1978) : Temporal Variability Patterns and the Distributional Patterns of Stream Fishes. *Ecological Monographs*, 48, 307-321.
- Hughes J.M.R., Barry J. (1989) : Hydrological Regionalisation of Streams in Victoria, Australia, with Implication for Stream Ecology, 40, 303-326.
- ICIMOD (1996) : A Preliminary Field Assessment of the Debris Flow Disaster of July 22, 1996 at Larcha in Upper Bhotekosi, Sindhupalchok District, Nepal. Mountain Natural Resources Division, ICIMOD, Kathmandu.
- Ives J.D., Messerli B. (1989) : The Himalayan Dilemma, UNU/Routledge, London.
- Jowett I.G., Duncan M.J. (1990) : Flow variability in New-Zéland rivers and its relationship to in-stream habitat and biota in New-Zeland. *Journal of Marine and Freshwater Research*, 24, 305-317.
- Jowett I.G., Richardson J. (1989) : Effects of a severe flood on instream habitat and trout populations in seven New-Zeland rivers in New-Zeland. *Journal of Marine and Freshwater Research*, 23, 11-17.
- Khanal N. R. (1996) : Assessment of Natural Hazards in Nepal. A report submitted to Research Division, Tribhuvan University, Kirtipur, Kathmandu.
- Lamouroux N., Capra H., Pouilly M. (1995) : A perspective to predict habitat suitability of lotic fish : linking statistical hydraulic with multivariate habitat use models. Proceedings of 2^o international symposium on habitat hydraulics. Volume B. 95-106.
- Li T. (1996) : Landslide Hazard Mapping and Management in China, ICIMOD, Kathmandu: p. 1.
- Malafosse A. (1996) : Descripteurs de la variabilité hydrologique temporelle pouvant structurer les peuplements des écosystèmes d'eau courante. Cemagref publication. PhD report in hydrology. 250 p.
- Ministère de l'Environnement (1990) : Les études préliminaires à la cartographie réglementaire des risques naturel majeurs, La Documentation française, 142 p., juin 1990.
- Minshall G.W. (1988) : Stream ecosystem theory : a global perspective. *J.N. Am. Benthol. Soc.*, 7(4):263-288.
- Molin Valdes H. (1994) : the international decade for natural disaster reduction and the link with agenda 21, *Ecodécision*, pp 42-45, Avril 1994
- Oberlin G. (1994) : Contribution à une gestion intégrée du patrimoine des eaux continentales, par une protection raisonnée et négociée contre les inondations dommageables. Académie des Sciences (CADAS) et Conseil Economique et Social, Paris.
- Poff N.L., Allan D. (1995) : Fonctionnal organization of stream fish assemblages in relation to hydrological variability. *Ecology*, 76(2), 606-627
- Poff N.L., Ward J.V. (1989) : Implication of Streamflow Variability and Predictability for Lotic Community Structure : A Regional Analysis of Streamflow Patterns. *Canadian Journal Fisheries Aquatic Science*, 46, 1805-1818.
- Poff N.L. (1992) : Why disturbance can be predictable : a perspective on the definition of disturbance in streams. *Journal of North American Benthological Society*, 11, 86-92.
- Resh V.H., Brown A.V., Covich A.P., Gurtz M.E., Li H.W., Minshall G.W., Reice S.R., Sheldon A.L., Wallace J.B., Wissmar R.C. (1988) : The role of disturbance in stream ecology. *Journal of North American Benthological Society*, 7, 433-455.
- Sauquet E. (1996) : Analyse méthodologique des potentialités de régulation diffuse sur les affluents de la Loire. Dans : Approche écosystémique du bassin de la Loire", rapport intermédiaire n° 3, Ministère de l'Environnement et Cemagref Lyon.
- Southwood T.R.E. (1977) : Habitat, the template for ecological strategies ? *J Anim Ecol* 46 :337-365.
- Statzner B., Resh V.H. (1993) : Multiple site and -year analysis of stream insect emergence : a test of ecological theory. *Oecologia* 96, 65-79.
- Stearns S.C. (1981) : On measuring fluctuating environments : Predictability, constancy, and contingency. *Ecologie*, 62, 185-199.
- Torterotot (1994) : un cadre pour l'analyse socio-économique des dommages dus aux inondations, in Gestion intégrée des milieux aquatiques, Presses de ENPC, Actes des 5^o journées du DEA Sciences et Techniques de l'Environnement, 19-20 mai 1994
- Verghese B.G (1990) : Waters of Hope, Oxford and IBH, New Delhi.
- Ward J.V., Stanford J.A. (1983) : The intermediate-disturbance hypothesis : an explanation for biotic diversity patterns in lotic ecosystems. In fontaine T.D. Bartell S.M. (Eds.), Dynamics of lotic ecosystems. Ann Arbor, Michigan : Ann Arbor Science. 347-356

Conclusions

Progress in regional hydrology through FRIEND

Progrès réalisés en hydrologie régionale grâce à FRIEND

A. Gustard, G. Oberlin

1 A philosophical perspective

The FRIEND programme has contributed to a philosophical debate concerning the science and the future of regional hydrology. Two key questions were addressed. The first was linked to the fundamentals of our science (Klemes, 1986). The authors who stimulated this debate recalled that Hydrology could be corrupted by developments based on weak, personal, or invalidated hypotheses. Weak hypotheses can arise in Hydrology due to the need to answer short term problems with inadequate knowledge. This may result in premature conclusions based on invalidated hypotheses. Another reason is the complexity of Hydrology, which may need to use a simplified lumped hypothesis; but this should be chosen carefully, be validated and, as with any hypothesis in science, not left to subjective decisions. Progress has also been inhibited by an analytical fundamentalism too narrowly limited on analytical aspects based on micro-physical laws. Other approaches, e.g. macro-physical laws, systems synthesis, and regime modelling or regionalization were either ignored or not taken in account. In addition, the non-stationarity of hydrological data or the inadequacy of, for example, the Navier-Stokes equations were ignored or inadequately addressed. Scale effects were also misunderstood or under-developed, and a gap developed between Hydrology and its neighbouring sciences, postponing the opportunities of developing scientific advances, for example in hydroecological problems.

The second question was linked to the estimation of runoff in atmospheric sciences (see for example Dickinson, 1992). This meteorological development occurred with an ignorance of Hydrology and assumed that runoff was not understood prior to atmospheric modelling:- another aspect of the micro-physical fundamentalism referred to above. The hydrological approaches were considered to be at an inappropriate scale in relation to the physics of water movement and were more or less discredited. However, this second issue remained in a scientific context and comparisons between hydrological and meteorological runoff estimates were undertaken (numerous xPEX experiments under GEWEX programmes) and the limits of meteorological approaches were highlighted. As a result, a more realistic balance between meteorology and hydrology is now developing, resulting in the coupling of meteorological and hydrological models, with advantages for both water balance computations and our understanding of the water cycle.

This debate made these two questions fundamental to the FRIEND project during the Eighties. FRIEND focussed on Regional Hydrology and exploited mainly regional approaches, either directly (deriving regional relationships from hydrological data), or indirectly (deriving improved local relationships based on hydrological processes), or by interpolating in space exploiting direct and indirect approaches. The FRIEND Groups developed the scientific framework to tackle these questions, with a strategic approach but with a wide range of opinions, ensuring validation of the selected hypotheses. The practical result, for the international hydrological scientific community, was

a constructive development in both the concepts, application and validation of Regional Hydrology. In addition to this evolution, several FRIEND participants have adopted a physical approach to regionalization to ensure close links between the regional statistical approach and the more analytical one. An example is project 5 in the NE Group. Another is the strong support given by FRIEND participants to networks devoted to Analytical Hydrology. For example, the European ERB network was launched (in the Eighties) by the staff who later launched the AMHY Group (GIP HydrOsystemes, 1994), and the ERB tasks are now assumed mainly by NWE and AMHY participants. These last features, together with the more mature status of Hydrology in general, have enabled significant progress in Regional Hydrology supported in part by the FRIEND research programme.

2 Progress in regional hydrology through FRIEND

In discussing scale problems in hydrology, Klemes (1983) argued that a successful solution to a problem is more likely if it is approached from two different directions. He advocates using "upward" and "downward" routes in the search for meaningful conceptualization in hydrology. The first route attempts to develop theories at a detailed lower level of scale to predict characteristics to be expected at a higher hydrological level of scale. The "downward route" begins with a distinct concept at a scale at or above the level of interest and then looks for the steps that could have led to it from a lower level. The FRIEND research programme has widened the range of scales which have been studied from detailed hydrogeological modelling of small basins to estimating runoff at the grid scale over Europe and Africa.

The FRIEND project has demonstrated many of the advantages of international cooperation in hydrological research. First, by using the resources of a large project team it has been possible to assemble extensive international databases. Second, models, analysis techniques and particular specializations from different countries have been applied to this data. Third, regional studies have benefited from applying analysis techniques to datasets not constrained by national boundaries and from using research basin data which provided most of the data from small basins. Finally the project has brought together hydrologists with different experiences ranging from «process hydrologists» to «regional surface water hydrologists».

The understanding of hydrological variability and similarity on a regional basis has improved considerably due to the work of the FRIEND project. The application of regional data sets in hydrological analysis has brought about an improved appreciation of hydrological behaviour and contributes significantly to the characterisation of flows at ungauged sites. Initiated in 1985, the FRIEND project originally involved 13 nations in northern and western Europe. The growth of interest in the FRIEND project has been such that now over forty countries collaborate in the research activities of the four international FRIEND research programmes. FRIEND was designated Project 1.1 of IHP V for adoption by the Intergovernmental Council in February 1995 and it is anticipated that this will encourage further developments in the scientific and geographical extension of the international research programme.

3 Institutional benefits of FRIEND

Of equal importance to research outputs are the longer term institutional benefits of enhanced international cooperation. It has been very difficult for scientists in the former Eastern block and developing countries to keep abreast of developments in hydrology due to the limited availability of scientific literature and problems associated with international communication. Against this background, international projects such as FRIEND, which combine close scientific cooperation with network development, are extremely beneficial. Another important aspect associated with international cooperation is motivation. The opportunity to present results of scientific work on the

international level can be a strong motivating factor for many researchers. In addition to these general benefits of international cooperation, there have been the following specific achievements of benefit to participants and their institutes:-

- International exchange of experience and knowledge of research scientists.
- Exchange of data, methods, computer programs and scientific literature.
- Fast development of methods and relevant software resulting from compilation of experience and knowledge of members from different countries.
- Verification of techniques used in different countries on data representing contrasting meteorological, hydrological, geological and other conditions.
- Joint preparation of progress reports, published papers and contributions to conferences.
- Improving the scientific basis for resolving operational water resource problems.
- Development of wider contacts and cooperation of participants and their research institutes or universities.
- Experience of scientific project management, synthesis of results and dissemination to the research community
- Training in data base management and hydrological techniques.

De l'analyse à la synthèse en Hydrologie : des niveaux pertinents de modélisation

From analysis to synthesis in Hydrology : some adequate levels of modelization

G. Oberlin, E. Desbos

Introduction

Parmi le grand nombre d'avancées et de résultats méthodologiques produits dans FRIEND, ou induits plus ou moins directement par le développement de ce projet PHI d'hydrologie régionale, on note une contribution approfondie sur le plan épistémologique. En effet, en concomitance, sinon parfois en synergie, avec d'autres projets et d'autres problématiques, et en particulier avec tout ce qui concerne l'écohydrologie et les approches scientifiques de l'environnement (par ex. la formulation scientifique des réalités que doit prendre en compte la gestion intégrée des eaux et de leurs milieux), est apparue la nécessité de redéfinir des niveaux différenciés de modélisation en hydrologie, pour une meilleure adéquation d'un modèle à sa problématique scientifique. Ces niveaux, antérieurement définis seulement selon des axes d'échelles (temporelles et spatiales), se sont ici orientés selon des besoins d'interfaçage, entre autre avec les autres sciences connexes concernées. Pour résumer la démarche développée, on a proposé de définir un axe nouveau, allant de l'analyse à la synthèse, et pouvant servir tout à la fois l'hydrologie seule sensu stricto et la bonne articulation de l'hydrologie avec les autres sciences, ou avec des usages comme la gestion des eaux, ou encore avec une bonne modélisation à bases scientifiques des divers besoins des milieux et de la société.

On notera que cet effort pour donner à la synthèse toute sa place, et aussi lui assurer une significativité scientifique maximale, dépasse largement le cadre de l'hydrologie et concerne a priori toutes les sciences, et sans doute toutes les analyses. Ce qui est ici un peu innovant, c'est la volonté de donner aux synthèses une légitimité scientifique équivalente à celle des analyses, aussi de parler de modèles (scientifiques) de synthèse, et enfin d'aborder objectivement le vaste domaine des modèles d'interfaçage entre sciences. Ces derniers points, sans doute également universels en sciences en général, sont toutefois particulièrement présents en hydrologie, compte tenu de la complexité des cycles de l'eau, et aussi des très nombreuses implications de ces cycles dans nombre de problématiques scientifiques concernant les milieux naturels (hydrobiocénoses, qualités des eaux et hydrogéomorphologie, en particulier) et la société.

1 Une question-clé pour l'hydrologie

On peut sommairement résumer les démarches de l'hydrologie avec le schéma de la fig. 1 : des modèles analytiques ou synthétiques présentent les données de base ou de synthèse des écoulements induits par les cycles de l'eau en milieux plus ou moins naturels. Ces derniers sont décrits et observés quantitativement, ainsi que les écoulements dont ils sont le siège, pour valider les hypothèses et lois de ces modèles (mesures). Les modèles, une fois validés, peuvent servir à simuler des données de base (surtout les modèles analytiques) et des données de synthèse (surtout les modèles de synthèse). Le tout (données observées et simulées) peut produire des cartes de régimes d'écoulements. Si, en outre, les demandes (société, milieux naturels, sciences connexes, etc...) sont modélisées de manière adéquate (surtout via les modèles de synthèse), on peut confronter objectivement demandes et régimes, et aboutir à d'autres cartes, ou à des conclusions, opérationnelles pour la gestion des eaux et de leurs milieux. Si cette gestion conduit à modifier significativement les milieux concernés (travaux hydrauliques, par exemple), l'ensemble peut faire l'objet d'un rebouclage pour vérifier le maintien des

régimes hydrologiques, ou pour en estimer les évolutions s'il y a lieu. Dans ce schéma général, la validation la plus forte se situe dans les observations (mais seulement si elles sont bien menées) et dans les modèles analytiques à bases physiques solides (mais seulement s'ils sont appliqués de façon adéquate). L'hydrologie régionale se situe au niveau des modèles dits de synthèse, peu ou prou éloignés des bases physiques des modèles analytiques.

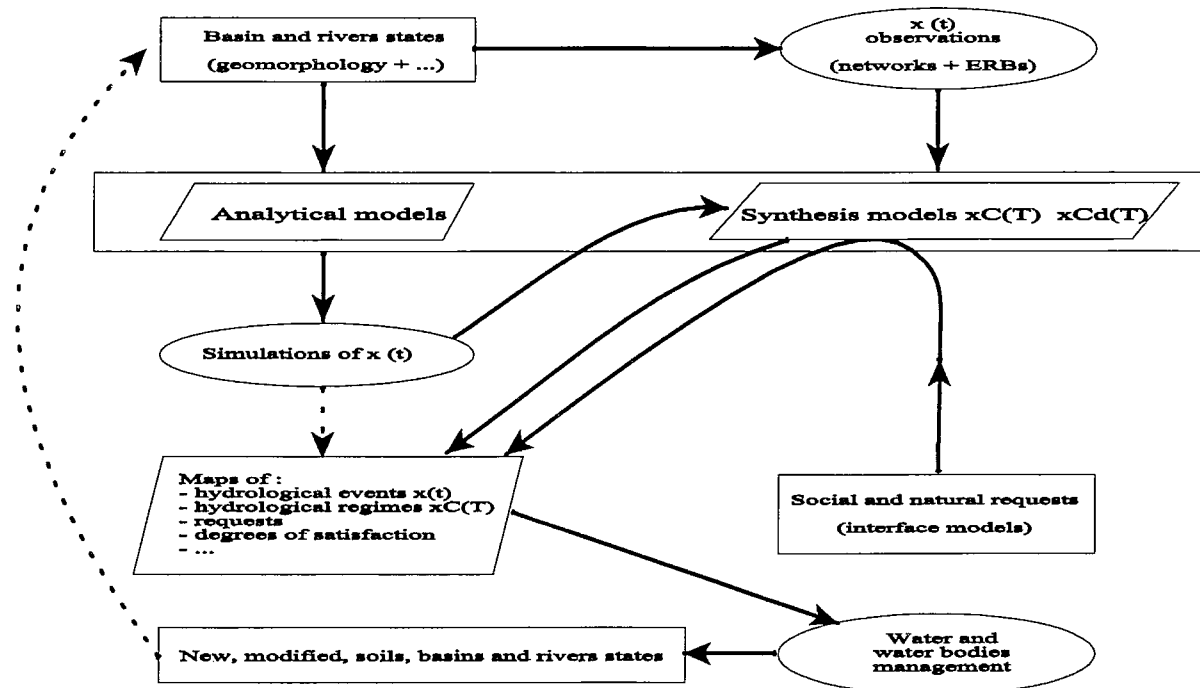

Figure 1 : Schéma général des principales démarches de l'Hydrologie

Figure 1 : General scheme for the main hydrological approaches

Le programme FRIEND, qui vise la connaissance des régimes d'écoulements, est donc particulièrement interpellé quant à la pertinence de ses hypothèses et concepts de base, et surtout quant à leur solidité scientifique et à leurs possibilités de validation. Il est en effet quasi-impossible, et en tous cas scientifiquement incorrect, de modéliser les régimes et les comportements régionaux des écoulements, via des modèles d'écoulements élémentaires déjà validés, tels que ceux dérivés des équations de Navier-Stokes. La situation est un peu moins défavorable pour les équations de la thermodynamique sensu stricto, mais on retrouve les mêmes difficultés pour les équations aérodynamiques de l'atmosphère. Cette interpellation a été particulièrement vive compte tenu des débats de fond qui ont émergé en hydrologie à peu près à l'époque de la naissance de FRIEND, et a été encore renforcée par les hypothèses de moindre stationnarité des régimes liées aux éventuels modifications climatiques. Mais, même sans ces derniers rappels conjoncturels, le problème de la bonne approche scientifique de connaissances aussi synthétiques que celles des régimes reste de toutes manières fondamental en hydrologie. En effet, il suffit d'avoir pu aborder, par quelque moyen que ce soit, la terrible complexité et instationnarité des divers cycles de l'eau (caractéristiques physiques des terrains concernés incluses !), pour comprendre la relative ineptie consistant à appliquer certains modèles analytiques dans ces conditions, ou la mission impossible que représente la mesure de qualité suffisante (pour que les incertitudes ne torpillent pas la qualité des résultats) des trop nombreuses données nécessaires aux modèles très analytiques en hydrologie.

En outre, le développement récent de sciences plus synthétiques, comme toutes celles liées à l'écologie ou à la gestion des eaux et des milieux, pose un problème relativement nouveau d'articulation et d'interfaçage : comment assurer à ces nouvelles sciences un maximum de solidité

scientifique et de capacités de validation ? On peut être tenté de les redéfinir ex-nihilo, mais ce serait sans doute inefficace de faire ainsi table rase des connaissances accumulées dans leurs sciences connexes et plus ou moins d'origine, dont l'hydrologie. Mais pour exploiter des connaissances disponibles, il faut créer des concepts et des modèles d'interfaçage objectifs et scientifiquement validables, entre ces sciences plus élémentaires d'origine et les sciences plus synthétiques d'avenir. Quand on essaye de répondre à une telle question, on découvre très vite la relative complexité des problèmes, et on observe que les idées antérieures en matière d'analyse et de synthèse, ou en matière de multi- ou pluri-disciplinarité, sont encore assez frustes, si ce n'est simplistes, et en tous cas largement insuffisantes vis à vis de l'ampleur et de la diversité des questions rencontrées.

Enfin, en aval des sciences sensu stricto, quand on aborde sérieusement et scientifiquement les techniques et pratiques de la gestion intégrée des eaux et de leurs milieux, on redécouvre non seulement la réalité connue des insuffisances de fondement scientifique de nombre de techniques de gestion, mais on découvre également, et c'est relativement nouveau, la relative inadéquation des connaissances disponibles, et à tout le moins de leur formalisation (de leur modélisation).

En conséquence, il apparaît que si l'on veut bien gérer la science hydrologique, c'est-à-dire lui assurer une pertinence vis à vis des sciences connexes qui en ont besoin, mais aussi lui donner une utilité sociale sans laquelle la société la laissera tomber, il faudrait aborder tout ou partie de ces problèmes de développement et d'élargissement cités sommairement ci-dessus, bien sûr avec toute la rigueur scientifique nécessaire. Se contenter d'assurer une meilleure assise physique au niveau de l'analyse à micro-échelle, comme cela est le cas depuis quelques années, ne semble pas être une réponse suffisante, même si ces efforts d'analyse sont évidemment tout à fait nécessaires et sans doute un préalable indispensable.

2 Un axe possible de niveaux de modélisation allant de l'analytique au synthétique

Pour exploiter les considérations précédentes, on a d'abord convenu de la création d'un axe allant de l'analyse la plus fine possible à la synthèse la plus large encore qualifiable scientifiquement. Pour mieux manifester l'indispensable base analytique de toute science, on a décidé une représentation en forme d'anneaux concentriques, le coeur (anneau-disque interne) représentant le niveau le plus précieux et les anneaux concentriques successifs des niveaux de plus en plus synthétiques (de plus en plus dégradés analytiquement). Pour également signifier sans ambiguïté la nécessaire base expérimentale et d'observation (mesures et alter) d'une science du milieu naturel comme l'hydrologie, on a considéré que le modèle le plus analytique possible était ... l'hydrosphère elle-même, équipée ou non des réseaux d'observations et de mesures (réseaux généraux mais aussi site-observatoires de recherche comme les BVRE et alter). Pour ne pas évacuer les expérimentations lourdes de type modèles réduits, peu utilisées jusqu'à présent en hydrologie sensu stricto, mais beaucoup en hydraulique, et peut-être en phase de redéveloppement par suite des récents domaines de recherche ouverts en écohydrologie et en hydrobiogéochimie, un premier anneau a été affecté à ces modèles physiques d'échelle spatiale plus ou moins réduite. Vient alors seulement le niveau (anneau) des modèles mathématiques à base de lois physiques (déterministes). Les niveaux abordant partiellement la synthèse démarrent avec un anneau dédié aux modèles conceptuels mais distribués, suivis des conceptuels globaux. On place alors le niveau de synthèse sensu stricto, le plus utilisé dans FRIEND et en hydrologie régionale, c'est-à-dire celui qui modélise l'ensemble d'un régime d'écoulement.

On aurait pu s'arrêter là, en qualifiant les autres niveaux de modélisation de niveaux trop éloignés des approches scientifiques. En fait, l'approche scientifique ne se définit pas vis à vis de l'analyse, mais plutôt vis à vis de la méthode employée : dès lors qu'on pose clairement un problème, qu'on lui affecte des concepts adéquats, qu'on lui applique des hypothèses clairement définies, que ces hypothèses sont rigoureusement testées via des variables et modèles dûment validables, et que des conclusions claires sont données et justifiées (hypothèses annulées, confirmées ou nuancées), on est bien dans le domaine de la science, et selon une acception habituelle et pratiquement reconnue de

tous. On a donc poursuivi quelques niveaux de modélisation encore plus "dégradés" par rapport aux analyses, mais toujours abordables de manière scientifique : modèles sommaires, puis modèles de cartographie, et enfin modélisations des besoins et des demandes des milieux (société humaine, ou biocénoses, voire ceux de sciences connexes). Pour clore cette structure avec un accrochage social, on a ajouté un dernier anneau, représentant plus un voeu d'avenir qu'une réalité présente : les modèles scientifiques ultimes proposés comme bases pour les lois et règles qui régissent la société et son droit.

On aboutit ainsi à un schéma cohérent et relativement complet de l'ensemble des niveaux de modélisation possibles en hydrologie (fig. 2).

3 Quelques nouveaux point-clés de la modélisation synthétique en hydrologie

On n'aborde pas, ici, les point-clés des domaines analytiques, ni les bonnes procédures de validation. De nombreuses références existent (par ex. n° spécial Vol. 175, 1-4, février 1996, Journ. Hydrol., pour des analyses se préoccupant aussi des grands systèmes). On se limite à quelques innovations spécifiques induites par des approches de modélisation plus ou moins synthétiques.

Une première contrainte qui apparaît en abordant scientifiquement des modèles de synthèse est l'obligation d'entrer structurellement le filtrage des chroniques dans les variables modélisées. En analytique, on travaille sur des variables hydrologiques x simulées continuellement selon le temps courant t , de manière à produire des chroniques continues $x(t)$. Ensuite, par exemple en validation ou en présentation résumée des résultats, on extrait éventuellement de ces chroniques $x(t)$ des caractéristiques C de synthèse, comme des $x_C(t)$, voire des comportement-types de ces variables (leurs "régimes") sous la forme de relations $x_C(T)$, où T a la signification d'une probabilité (par exemple une période moyenne de retour). En modèles synthétiques, par contre, la variable de base sera $x_C(t)$, voire $x_C(T)$, et le modèle de synthèse aura à traiter directement ces caractéristiques plus ou moins synthétiques, sans faire appel aux chroniques courantes $x(t)$. L'hydrologie étant fortement structurée par le temps, l'interprétation synthétique de ce temps est la durée d , et nombre de modèles de synthèse gagneront donc à travailler en variables $x_C d(T)$. Les expériences menées à l'occasion de FRIEND (voir par ex. les travaux en modèles de synthèse dits $x d F$) montrent de remarquables émergences de propriétés, et d'intéressantes consolidations, toutes choses précieuses en science en général, mais surtout en hydrologie où elles sont rares.

Un objectif omni-présent en hydrologie de synthèse est la cartographie, qu'il s'agisse de synthétiser régionalement des résultats locaux plus analytiques, de représenter des connaissances (locales et/ou régionales), de porter les acquis de l'hydrologie sur les milieux concernés (une zone humide, par exemple), de signifier à la société les réalités hydrologiques à l'échelle de ses spéculations foncières (les aléas de crues inondantes sur un lit majeur exploité, par exemple), ou de dériver (reanalyser) depuis des cartographies de variables locales des connaissances spatiales (variogrammes, ou coefficients d'épicentrages, par exemple), etc... Plus ou moins reconnu de longue date, cet objectif n'a guère été l'occasion, à la brillante exception de la géostatistique près, de travaux scientifiquement bien fondés, et beaucoup de cartes publiées tenaient davantage de l'oeuvre d'art, fut-elle commise par un expert hydrologue qualifié, que de la modélisation objective sensu stricto. Compte tenu de l'importance des cartes en hydrologie régionale et en synthèse régionale des régimes, on comprend l'importance accordée par FRIEND à cet aspect. Pour progresser dans le sens d'une meilleure assise scientifique de la cartographie hydrologique, trois point-clés ont été introduits dans les travaux :

Different levels of modelization in Hydrology

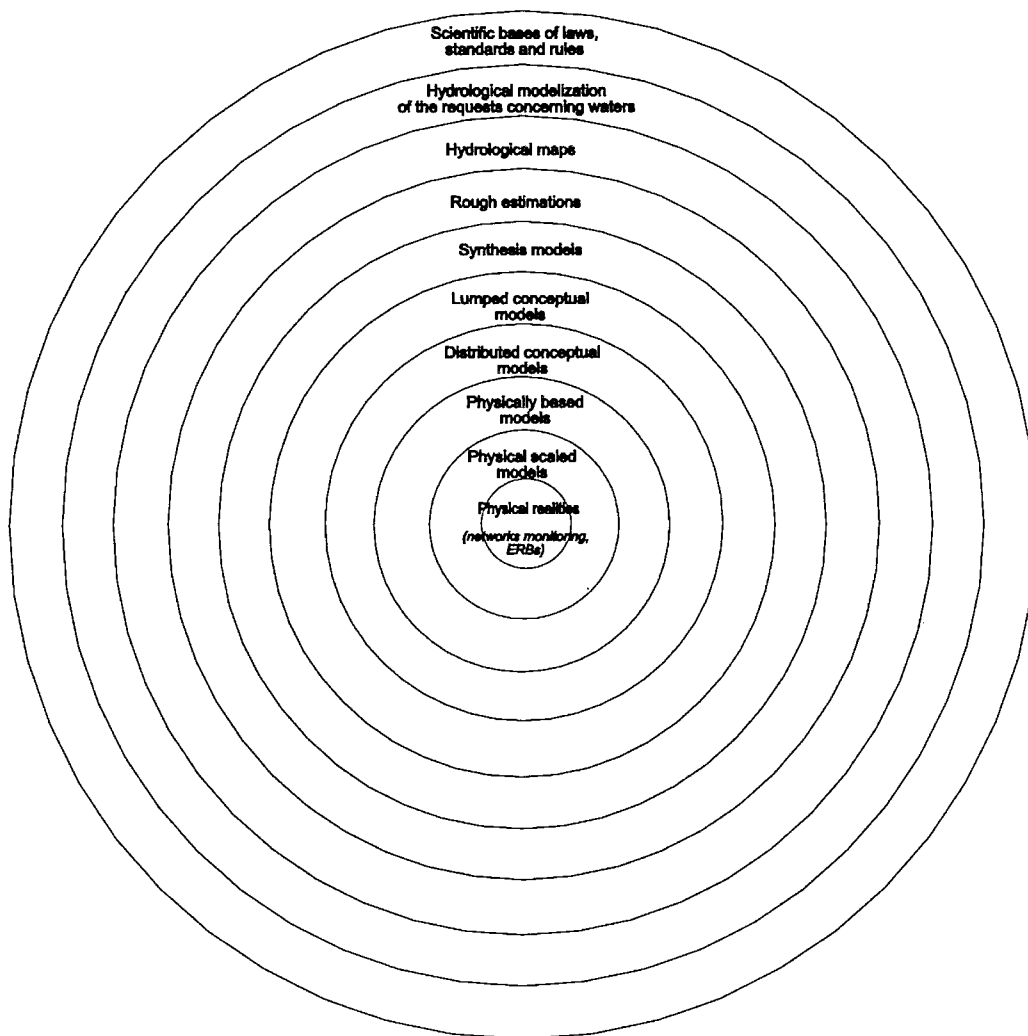

Figure 2 : Divers niveaux de modélisation en Hydrologie, selon un axe principal "de l'Analyse à la Synthèse", en vue d'un meilleur interfaçage entre l'Hydrologie et les sciences connexes

Figure 2 : The different modelization levels in Hydrology, structured on a main axis "from Analysis to Synthesis", for a better interfacing of Hydrology toward other sciences

- ne cartographier que ce qui est modélisable, par un modèle sensu stricto (fut-il de synthèse) traitant de variables quantifiées en entrée et en sortie, et validable ;
- prendre très sérieusement en compte la réalité topologique du recouvrement des écoulements (bassins emboîtés) quand ceux-ci sont cartographiés de façon maillée, et en tirer toutes les conséquences sur les représentations à retenir, sur les effets d'échelle, ainsi que sur les rétablissements de méthodes (de concepts, de résultats, ...) antérieures si nécessaire ; ce dernier point a abouti à un important concept présenté sous le sigle RESEDA (effet du même nom).
- exploiter les propriétés relatives d'ergodicité que présentent nombre de chroniques hydrologiques.

Un autre point-clé en modélisation plus ou moins synthétique, est celui de la modélisation rigoureuse, et en des termes comparables à ceux décrivant les écoulements, des divers besoins définis vis à vis de l'eau, qu'il s'agisse des besoins des milieux naturels ou de ceux de la société. Ceci paraît absolument essentiel si l'on veut récupérer (par rapport aux abus passés), d'une part, les assises scientifiques de la gestion des eaux et, d'autre part, l'articulation scientifiquement fondée de l'hydrologie sur la gestion

des eaux. L'enjeu est ici capital, tant pour la crédibilité sociale de l'hydrologie que pour la crédibilité scientifique de la gestion des eaux. Il est piquant de constater que c'est pour l'essentiel à cause du développement de l'écologie (et donc de l'hydroécologie et de l'écohydrologie) que ce point-clé a émergé et a commencé d'être servi par des approches synthétiques de modélisation plus rigoureuses. La société, bien qu'ayant défini ses besoins en eaux de bien plus longue date, n'a guère été moteur dans cette récente évolution. Bien entendu, elle en profite à présent (voir par ex. les modèles hydrologiques liés à la désagrégation du concept de risque en ses deux composantes d'aléa et de vulnérabilité).

Un dernier point-clé cité ici est l'émergence du concept d'épicentrage, qui peut caractériser des propriétés spatiales particulières d'une variable ponctuelle analysées dans un grand domaine. Ces propriétés ne sont pas indépendantes du principe d'ergodicité relative déjà cité plus. Eminemment synthétique, ce concept d'épicentrage permet un certain nombre de progrès en hydrologie régionale et locale, dont il serait dommage de se priver en modélisation de synthèse. Et son exploitation est quasiment inatteignable aux approches seulement analytiques, bien que celles-ci puissent lui apporter des validations de plausibilité physique. Par la consolidation des connaissances qu'il apporte localement (directement, ou indirectement via l'exploitations de la relative ergodicité), il conduit également à l'émergence de propriétés et de lois de comportement aussi remarquables qu'inattendues.

4 Les liens et la cohérence à assurer entre tous ces niveaux

A priori, les premiers usages et interprétations faits sur cette structuration des niveaux de modélisation selon leur degré relatif d'analyse ou de synthèse, se sont révélés utiles, pertinents et de nature à clarifier la problématique hydrologique. Cela devrait contribuer à la "qualité" de cette science. Il est cependant indispensable qu'une telle diversification des modèles assure plus objectivement, c'est-à-dire au-delà de cette "bonne impression" relativement subjective, sa cohérence interne, et sa propre validation. Il faut pour cela, une fois les niveaux supposés bien choisis, vérifier leur propre interfaçage interne, et sans doute leur validation réciproque au moins deux à deux (au moins entre anneaux adjacents). A ce prix, on assurerait un continuum de validation, depuis les analyses les plus fines et les plus physiques possibles jusqu'aux synthèses les plus ambitieuses, et on réconcilierait du même coup analyses et synthèses.

Pour l'aspect de validation réciproque, il ne semble actuellement pas y avoir d'autres voies que celle de la double ou triple modélisation : un objet hydrologique donné, qui est modélisé principalement selon le niveau (l'anneau) choisi, devrait à titre de validation de ce modèle faire aussi l'objet d'une ou deux autres modélisations, en essayant le(s) niveau(x) immédiatement voisin(s), puis d'une comparaison-discussion de ces divers résultats avant conclusion. Contrairement aux idées reçues, un niveau plus ou moins synthétique (anneaux autres que les plus centraux) n'aurait donc pas, du moins a priori ou seulement, à être validé par les (seuls) niveaux analytiques de base ; cette règle éviterait les usages déplacés de modèles analytiques (issus de Navier-Stokes, en particulier), lorsqu'ils sont appliqués hors objets et données adéquats.

Pour le contrôle de cohérence de l'ensemble, il pourrait être fait appel à deux ou trois axes secondaires permettant aussi de structurer ces niveaux de modélisations : celui de l'espace géométrique (échelle spatiale), celui de l'espace temporel (échelle temporelle), et celui de la complexité (nombre de processus élémentaires concernés, n). La fig. 3 présente qualitativement les niveaux définis plus haut sur deux des axes secondaires proposés ici (l'axe temporel, très lié au spatial, n'a pas été figuré). Pour passer de ce schéma qualitatif à un schéma plus objectif, il faudrait essayer de quantifier des valeurs adéquates de s (taille de l'objet hydrologique modélisé) ou de n , et en particulier en déduire les plages (autour de s^* et n^*) d'inversion. Il est plus que probable que les paramètres s^* et n^* varient avec la complexité des objets hydrologiques (généralement, des bassins versants).

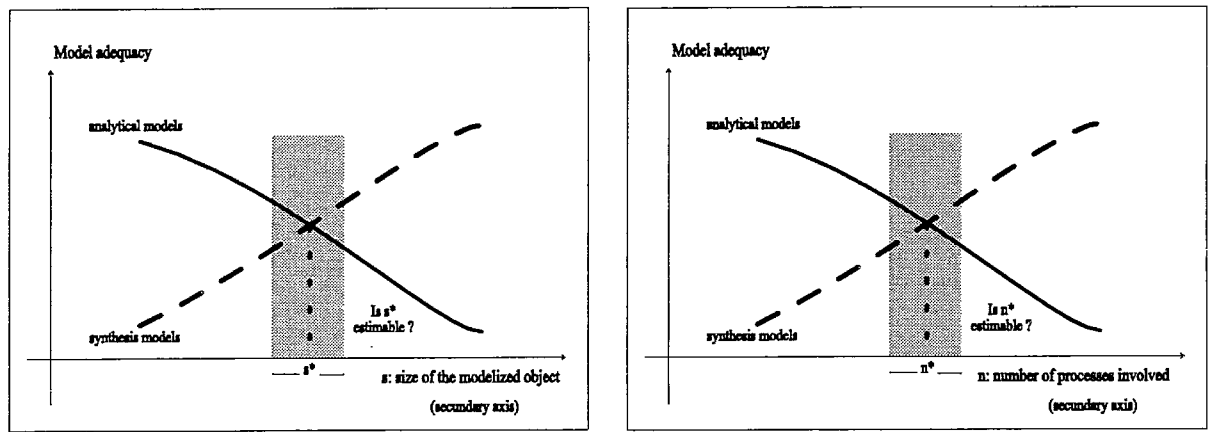

Figure 3 : Adéquation relative de l'analyse et de la synthèse selon deux axes secondaires
Figure 3 : Relative adequacy of analysis and synthesis along two secondary axes

Conclusion

Outre l'intérêt général, déjà cité plus haut, que semble présenter cette mise en cohérence et en continuité des modèles hydrologiques selon l'axe analyse-synthèse, on peut citer des exemples où cette structuration a autorisé d'intéressants développements, ou un affichage compréhensible de méthodes et de modèles hydrologiques complexes.

Par exemple dans le modèle dit Inondabilité (cf Chapitre "Regional Hydrology and Water Management"), plusieurs sous-modèles émergent à des niveaux (des anneaux ...) différents. Leur cohérence interne a gagné à ce qu'ils soient présentés selon l'axe proposé ici. Le schéma a permis de rationaliser l'ensemble, et d'économiser des sous-modèles. Enfin, les niveaux de validation les plus adaptés sont clairement affichés (niveaux adjacents).

De même, dans l'extension des modèles écohydrologiques d'habitats aux variabilités temporelles et aux échelles non ponctuelles (habitats de biefs et non plus seulement micro-habitats de section), l'explicitation du niveau très synthétique dénommé "Modélisations des demandes" a permis de délimiter une importante lacune dans les traditions d'analyse des variabilités hydrologiques temporelles : accaparés par l'objectif de définir des événements indépendants (selon les temps de réponse de leurs processus physiques), et des saisons bien typées, les hydrologues ont totalement négligé jusqu'à présent les analyses de variabilité liées aux diverses mémoires biologiques présentes dans les biocénoses des milieux aquatiques. De nouvelles variables, synthétiques, sont ainsi nées (cf Chapitre "The futures of FRIEND"), alors même que l'outil principal concerné était plutôt analytique (modèles hydrauliques de micro-habitats).

Pour le futur, la tâche prioritaire devrait être de confirmer les capacités de validation réciproque des niveaux adjacents du schéma proposé. Il n'est pas exclu pour cela que certains des niveaux affichés ici puissent être "sautés" (pour la validation, pas pour eux-mêmes). Si cela était mieux montré et démontré qu'aujourd'hui, on aurait définitivement réconcilié analyses et synthèses, bases physiques des processus et lois de comportement des régimes d'écoulement, et assuré à l'hydrologie le lot diversifié des modèles dont elle a besoin, et sans retomber dans l'absence de structuration de ses outils dont elle a tant souffert par le passé. Ce serait alors un progrès majeur pour les sciences hydrologiques.

Regionalization and subsidiarity : an example of hierarchical approach in flood control

Régionalisation et subsidiarité : un exemple d'approche hiérarchisée de la gestion des crues

D.Consuegra, E.Vez

Introduction

Depuis quelques décennies, la société a repris conscience de la valeur de son patrimoine naturel et de l'écosystème formé par la rivière. Les corrections de cours d'eau pratiquées dans le passé ne sont plus envisageables aujourd'hui. La planification des mesures de lutte contre les inondations doit abandonner le principe d'une évacuation intégrale pour se rapprocher de nouveaux concepts basés sur la gestion des crues. A la dimension classique de vecteur, il faudra ajouter celle du bassin versant compris comme une entité géographique spécifique définie par des activités économiques, des pressions sociales et des patrimoines naturels à respecter. Dès lors, la lutte contre les inondations n'est plus un objectif en soi. Elle fait partie d'un ensemble d'actions opérées à l'échelle du bassin versant. Cette extension du domaine décisionnel peut remettre en question des approches techniques ainsi que des structures législatives et administratives. Désormais, il faut définir des lignes directrices, faire des choix au niveau du bassin versant complet, les options locales devant se plier aux directives générales.

Les mesures de lutte contre les inondations résultent d'un processus hiérarchisé dans lequel on part d'une analyse d'ensemble pour se diriger progressivement vers le détail. Pour assurer une implantation adéquate sur le terrain, la planification devra être en mesure de négocier les passages d'échelle. Ces passages d'échelle devront se faire en toute compatibilité avec les structures sociales, administratives et juridiques de la région concernée. Ce processus hiérarchisé offre de nouvelles perspectives à la modélisation mathématique. En définissant des échelles de travail pour chaque étape, l'ingénieur doit rechercher des outils adaptés à chaque cas. La compatibilité entre les échelles devient alors une condition indispensable. Or, il est bien connu que les modèles mathématiques disponibles actuellement résultent d'hypothèses de base différentes et ne sont applicables que dans des conditions spécifiques. Il ne sont donc pas nécessairement compatibles entre eux. A notre avis, ce problème provient du fait que les modèles sont développés pour résoudre des problèmes spécifiques. Ils ne sont pas élaborés dans un contexte méthodologique de travail bien précis. Or, en Suisse, cette méthodologie fait cruellement défaut, notamment en matière de planification des mesures de lutte contre les crues. Ce n'est qu'en définissant les étapes de la méthodologie que l'on pourra ensuite rechercher ou développer des outils convenables et adaptés à chaque phase.

Concept de Gestion des Eaux de surface (CGE)

Le Concept de Gestion des Eaux de surface (CGE) développé (figure 1) est adapté au contexte helvétique tout en respectant les principes énumérés dans l'introduction (Consuegra 1992). Le CGE comporte donc trois étapes successives avec en premier un Schéma d'Aménagement Général des Eaux (SAGE) suivi de projets sectoriels (PS) et complété par des analyses de détail (AD). Le SAGE fournit les solutions techniques pour lutter contre les inondations à l'échelle des cours d'eau principaux. A chaque exutoire (points "charnière"), il spécifie également les débits en provenance de chaque affluent et peut éventuellement demander une réduction des apports des sous-bassins. Finalement, il fixe les directives pour l'élaboration des projets sectoriels et des analyses détaillées.

Les projets sectoriels (PS) ont pour but principal de résoudre des problématiques locales d'inondation au niveau des affluents et sur lesquelles le SAGE n'a pas pu s'attarder. Rappelons qu'à l'échelle du SAGE (quelques centaines de km²), il n'est pas possible d'analyser en détail des problématiques locales. Les projets sectoriels doivent également répercuter, à l'échelle du sous-bassin, les éventuelles contraintes imposées par le SAGE. Cet objectif peut être atteint en prévoyant des mesures de contrôle pour les surfaces subissant des modifications de l'affectation des sols ou encore par des mesures plus conséquentes au niveau de l'affluent lui-même. Pour faciliter la procédure d'implantation du CGE, il faudra que le SAGE permette aux projets sectoriels d'envisager le plus grand éventail de solutions possibles. Dès lors, le SAGE ne doit pas être trop contraignant au niveau des affluents en leur imposant des aménagements d'une certaine envergure, difficiles à faire accepter et à réaliser. Le projet sectoriel présente de fortes ressemblances avec le SAGE. Il s'en distingue par le fait qu'il s'effectue à une échelle plus réduite. Les exigences locales peuvent ainsi être prises en considération.

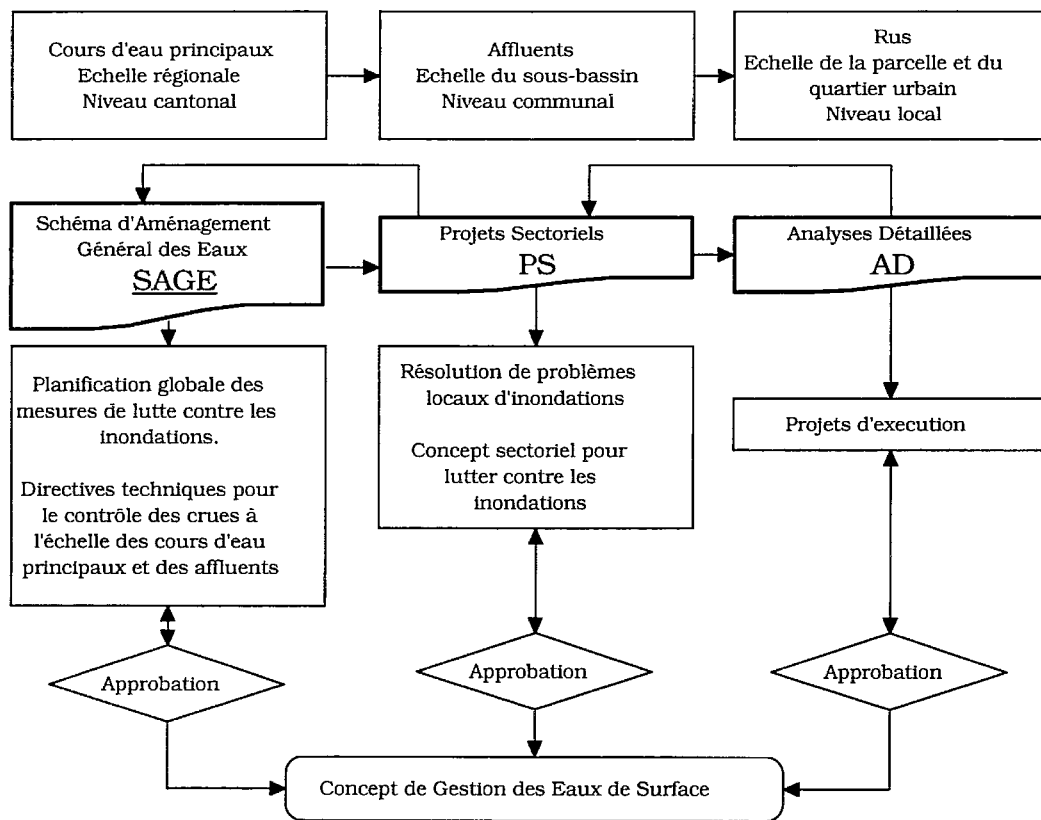

Figure 1 : Concept de Gestion des Eaux de surface proposé
Figure 1 : Definition of the general water management concept SAGE

Finalement, les analyses détaillées (AD) s'effectuent à l'échelle de quelques hectares. Elles se chargent de dimensionner les réseaux d'assainissement des futures zones urbaines ou des projets d'améliorations foncières. Ces analyses répercutent également les éventuelles directives issues des projets sectoriels (infiltration en zone urbaine, rétention en zone agricole, etc.).

Le processus de conception peut être itératif. Au niveau des projets sectoriels il se peut que l'on mette en évidence des incompatibilités ou des nouveaux éléments susceptibles de remettre en question les conclusions de la phase précédente. Une situation analogue peut se produire au niveau des analyses détaillées. La démarche proposée aboutit à une planification judicieuse des mesures de lutte contre les inondations à tous les niveaux, depuis l'échelle globale jusqu'au détail. La cohérence des valeurs de dimensionnement peut être assurée par la régionalisation de paramètres hydrologiques (Consuegra 1992), paramètres qui, selon les modèles choisis, peuvent rendre compte directement du découpage du bassin (AMIE1 1994, Consuegra et Vez 1996).

The Challenge for FRIEND

Le défi de FRIEND

J. C. Rodda

1 Introduction

When the concept of FRIEND was first introduced to the hydrological community and the International Hydrological Programme in the mid 1980s, it faced a number of challenges. Many of these have been overcome during the ensuing years as the concept has been turned into reality. But FRIEND is facing several new challenges as the 21st Century approaches. How these are handled will determine whether FRIEND is likely to have a future which will be as successful as its past.

2 A hydrological paradox

It is something of a paradox that hydrology, the science that deals with such a pervasive and ubiquitous substance as water, has always seemed to suffer from problems of acquiring and assembling data, particularly data at the regional and global scales. There are a number of reasons for these problems for example : concern about commercial competition, worries about foreign policy, anxiety over state security and a seeming lack of awareness at the governmental level of the environmental and human problems generated by water. Unfortunately these problems are usually most marked in river basins shared by a number of nations, just those circumstances where cooperation is the most vital. Then there are a number of other reasons that are probably more obvious, some which have emerged recently in certain regions. These include degrading hydrological networks and decaying systems for gathering and managing the data, declining competence of national hydrological services due to cuts in government support and decreasing investment in water projects. There are increasing difficulties of these types (Rodda, 1995), particularly in Africa and in the countries of the former Soviet Union.

There are also the arguments against assembling hydrological data. Some authorities consider that enough data have already been collected ; they point to the graveyards of data that exist unused in a number of countries. Others say that models can do everything and can produce the data that may be needed, so why bother to collect more. These are followed by arguments that data collection is too costly and that the so called 'rapid assessment methods' should be employed, rather than long term data collection programmes. Some say data collection should be tied to projects, and there are even those who claim that the design of structures is usually sufficiently robust to cope with inadequate data, even no data at all. So why bother to collect them they ask?

Dozier (1992) considers that the phenomenal increase in computer power in recent years has captured the interest of the hydrological community, with the consequence that data collection networks have been allowed to erode and the difficulties of assembling data sets have increased. There is also the point that in the past, members of the hydrological community appear to have been rather insular and not as good at working together within collaborative projects as other scientists. Oceanographers and meteorologists, for example, have a lengthy history of working together in teams. However this attitude has changed considerably in recent years, as funds have become more limited in certain countries and more regulated in others and the benefits of scientific cooperation have become more obvious to hydrologists.

3 The difficulties of data collection and management

Hydrological data are difficult to acquire, at least good quality data. Most data are collected from the field, rather than the laboratory and such an environment is usually hostile to instruments, to methods of observation and to the data collection systems as well. The least favourable circumstances pertain in mountainous regions. There the combination of factors—inaccessibility, extremes of temperature and humidity, coupled with ice accretion and wind, water and materials moving at high velocities make it very difficult to gather reliable data. Where access is easy vandalism is often a problem, particularly in urban areas where suitable sites may also be limited in number. A different problem is that hydrological processes operate over 15 orders of magnitude in space (Dooge 1984), while there must be a similar number in the time dimension. Normally the hydrologist is concerned with processes operating over four or five orders in terms of field observations, but even this more limited range gives problems, in the measurement of flow, for example. During recent years the spatial coverage has been improved by the use of remote sensing from satellites, aircraft and weather radar. However data from these sources can be difficult to obtain and costly and they are often of limited value because the sensors carried by many satellites have not been designed to meet hydrological needs. There is the important point that radar signals and images from space require calibration from instruments on the ground. These various difficulties and other such as and the fact that the presence of most instruments and methods of measurement disturb the medium being observed, give rise to errors in virtually every hydrological measurement.

To help overcome these problems, a number of codes of practice, guides and standards have been formulated, for example the WMO Guide to Hydrological Practices (WMO 1994). These result from international programmes such as WMO's Operational Hydrology Programme, the IHP and the UNEP/WHO/UNESCO/WMO GEMS Water Programme, often as a consequence of the comparison of the performance of instruments from different nations and the dissemination of the results. These programmes have also brought into being a number of world data centres where collections of hydrological data have been established in order to overcome the difficulties of access. Notable amongst these are the Global Runoff Data Centre at Koblenz in Germany and the GEMS Collaborative Centre for Surface and Ground Water Quality at Burlington in Canada. However, the data held at these and several other centres do not cover all countries, the most recent are frequently 2 to 3 years old and the time series are usually short and incomplete. This absence of a readily accessible and reliable body of hydrological data led WMO to propose the establishment of a World Hydrological Cycle Observing System (WHYCOS) (Rodda et al, 1993). WHYCOS would consist initially of about 1000 stations sited on these world's major rivers, existing stations in many cases, new ones in others. Each WHYCOS station would monitor about 15 variables including flow, water chemistry and on bank climate, which would be transmitted by geostationary satellites to national, regional and global data bases, where they would be available in near real time. Currently a WHYCOS network is being installed on the major rivers draining into the Mediterranean Basin and the Black Sea, while plans are well advanced for networks for the countries of southern and western Africa and also for the Nile Basin. WHYCOS would aim to operate for 20 years at the outset and through technology transfer assist those countries where networks, staff levels and competence are in decline, in order to provide tools for decision making as well as to aid the science of hydrology nationally and internationally. This decline has reduced the competence of many bodies and agencies concerned with assessment of water resources and it has occurred just at the time when the global demand for water is rising faster than ever before. In fact it seems a rather ridiculous situation that in the face of an accelerating demand for water, the ability to assess the world's water resources is being set back to the extent that it is worse now than it was in the 1970s.

4 A global scenario

Forecasting the future of the science is not a well developed area of hydrology, in contrast to the attention given to forecasting floods and similar phenomena. However, it is not too difficult to imagine a 21st Century where the global demand for water for drinking, irrigation, power generation and other purposes will continue to rise, bringing increased pressures on the world's finite water resources. Of course there are already many locations around the world where, at the present time, considerable difficulties exist for water supply, most due to the demand outstripping the available resource. Such circumstances provide pointers to the future and to the likelihood of increasing tension between nations sharing the water resources of international river basins. They also highlight the need for international agreements to regulate such basins, based, of course, on reliable hydrological data and their exchange between the nations concerned. In recent years droughts have exacerbated these shortages in certain regions as they will in the years to come, while the projected climate change is likely to cause alterations to hydrological regimes and to create further difficulties. The growth of the world's population is, of course, at the root of these problems, especially if the doubling which is expected by the middle of the next century actually takes place. Will the demand for water then be double or treble what it is today as a consequence? Or will it be even greater, because increasing affluence is adding to consumption per head? The growth of population must also generate a larger volume of pollution, particularly as a result of the extension of urban areas, and this pollution will reduce the available water resource. The doubled population will also present a bigger target for floods, landslides and avalanches as settlements grow in flood plains, valleys and in other vulnerable areas. While these increased pressures on water in the service of mankind alter the hydrological cycle in many ways, these alterations impact on the aquatic environment and the various living organisms that depend on it. Is it possible to contain these different thrusts within the limits of sustainable development; namely the need for water and for protection against its extremes together with the husbandry of the aquatic ecosystem? Such questions suggest that hydrology will have an increasingly important role as the science which is capable of expressing and defining sustainable development most clearly, underpinned by its three main areas of endeavour— water resources assessment, hydrological forecasting and prediction, together with environmental protection.

As the water scenario is advanced into the coming century, the future development of FRIEND seems to hinge not only on its relationship to likely developments within the general body of hydrology, but also on the success of its linkages with neighbouring areas of science. This suggests that in line with the growing importance of environmental protection, FRIEND should seek a significant water quality dimension to add to its achievements in the field of water quantity. There would be scope for aspects of water chemistry including natural isotopes and freshwater biology to be included. How this should be achieved is open to discussion, but one avenue would be to exploit further the cooperation that already exists within UNESCO between the IHP and the Man and the Biosphere Programme (MAB). Outside UNESCO's science programmes there is also the continuing cooperation under the GEMS Water Programme of UNEP, WHO, UNESCO and WMO which would be a second direction worth exploiting. These UN bodies and agencies are also co-operating with FAO and the International Council of Scientific Unions in one or other of the three global observing systems that are being developed: the Global Ocean Observing System (GOOS), the Global Climate Observing System (GCOS) and the Global Terrestrial Observing System (GTOS). The involvement of FRIEND, its data bases and techniques for data management and application, would be vital to GTOS and very important to the other two observing systems in the form they have been developing since the start of FRIEND. FRIEND would become an even more important component if it has a successful path into the water quality field. The relationship between FRIEND and WHYCOS needs developing, particularly the linkage between the two sets of data bases.

Another global issue which perhaps deserves greater consideration within the context of FRIEND is that of climate change. Climate change in the international context relates specifically to GCOS, to the Intergovernmental Panel on Climate Change (IPCC) and to the Framework Convention on

Climate Change with its meetings of the parties. Sound and reliable bodies of hydrological data and the products derived from them should have great potential for the search for signals of climate change and for investigating the likely impacts, not only on water resources, but also on the different sectors of economic activity ; agriculture, forestry, hydropower, and the like, where changes in the hydrological regime have greater consequences than changes in the meteorological variables, such as temperature. The assessments from IPCC have suffered from inadequate hydrological data and this has made it difficult to provide a satisfactory basis for conclusions in terms of hydrology and water resources. In addition, the Panel has seemed to lack an understanding of the significance of the impact of likely changes in the hydrological cycle on economic and social activities.

These are initiatives at the global level, but there are also opportunities at other levels. On the regional scale, for example, there are economic and political groupings of nations such as the European Union which have established bodies like the European Environment Agency which have extensive environmental responsibilities. These include strong interests in the quantity and quality of surface and ground water, interests which are of considerable relevance to FRIEND. Such opportunities need to be explored and exploited where this is possible.

Setting these areas of science aside, probably the greatest challenge for FRIEND is to reach into those parts of the world where parallel initiatives have not reached. Starting from its original study area in northern and western Europe, FRIEND has spread successfully to the east and south, so that it is now being implemented as far away as southern Africa. But there are certain regions and important river basins where the concept itself and the cooperation which ensures its success will be tested to the limit. This is the ultimate challenge.

The international co-operation induced by FRIEND

La coopération internationale induite par FRIEND

E. J. Berntsen,

At the 1984 Intergovernmental Council (IC) meeting of the UNESCO International Hydrological Programme (IHP), the representative from UK proposed to start a European project with the objective to encourage regional hydrological scientific studies at the European scale. This proposal was, at the time, more radical and visionary than it might seem today. To understand this, we have to recognise the history of scientific hydrology as it grew from the rather simple activities of the national surveys in mapping water resources for solving practical applications into the acknowledgement of hydrology as a geoscience in its own right. A distinguished group of American hydrologists formulated the following in the book "Opportunities in the Hydrological Sciences", published by the U.S. National Research Council in 1991:

"Over the past several years there has been an increasing concern among scientific hydrologists about the future and long-term vitality of their field. This is owing, somewhat paradoxically to the fact that throughout the history of this field applications have proceeded science.

The result is a scientific and educational base in hydrology that is incompatible with the scope and complexity of many current and emerging problems."

In retrospect we may say that the UK initiative at the 1984 IC-meeting which, in 1985, resulted in the establishment of a project organisation named FRENED (later renamed FRIEND-NE as more FRIEND projects appeared around the globe), located at the Institute of Hydrology, Wallingford, UK. This initial phase of FRENED can, in fact, be seen as an action oriented endeavour to put scientific hydrology in front of applications. The first phase of FRENED lasted for about three years and passed its first milestone by the first FRIENDS Conference in 1989 at Bolkesjø, Norway. During these three years the project group consisted of three scientists from UK and one from each of the countries : Germany, The Netherlands and Norway, working full time on the project, while scientists from a number of other countries joined the FRIEND-NE group at Wallingford for shorter or longer periods. In this context, it is important to observe that there was no central funding of the project, each country had to - as they still do - cover the expenses for their participation.

In order to make FRIEND-NE a truly regional European project it was essential that all the countries in the region became engaged in the project. As the regional studies were dependent on access to hydrological and other relevant data covering the whole region, the first task for the Wallingford group was to establish a regional hydrological database of river discharges. To facilitate the access to these data it was decided that countries intending to participate in the FRIEND-NE project had to provide data from their territory to the database. As all the countries have national institutions engaged in acquisition of these type of data, it was anticipated to be a relatively simple task.

The process of collecting data proved not to be simple, at all. The obstacles were on different aspects, from institutional lack of willingness to provide data, more or less dubious documentation of the quality of data provided, difficult accessible data storage formats, etc. And in 1985, as the Berlin wall still existed, data from the former Eastern Europe countries were considered to be of strategic importance and consequently not available. But soon after the political situation changed in 1990, the Central- and Eastern European countries joined the FRIEND-NE co-operation with great enthusiasm. At present scientists from some of the outstanding scientific institutions in these countries are now taking a leading responsibility in execution of the different sub-projects of FRIEND-NE.

However, as data from Northern and Western Europe were successively transferred to Wallingford a tedious process of refurbishing, verification and entering the data into the database was started. The updating and upgrading of the database are continued on a regular basis and the database is at present a very suitable tool for research purposes.

The establishment of the data base was, to a high degree, facilitated by the fact that the initial Wallingford crew was international. Each of the foreigners, from the UK point of view, took responsibility to promote the idea in their national sub-region about the necessity to establish a unified regional European database in order to facilitate the type of large scale scientific studies foreseen. The value of such regional studies has been well documented since 1985 as the interaction between hydrological systems behaviour and changes in the climate systems has become very focused.

The objectives of the FRIEND were, however, to study on hydrological characteristics at the regional scale related to flooding, low flows/droughts, run-off generation and hydrological response to human activities. These research themes have, with some modifications, been maintained as focal activities up to the present, - as they appear in the themes for this third FRIEND Conference.

The most accountable scientific achievements obtained since the second FRIEND Conference in Braunschweig in 1993 are well documented in the FRIEND report, the Conference Proceedings and the Poster presentations of this third FRIEND Conference. In addition there are a number of unaccounted and unaccountable achievements. In the education at different Universities students have produced a great number of master thesis and other unpublished studies, studies which have benefited from their professors engagement in regional analysis and large scale process studies that FRIEND projects and the FRIEND databases have facilitated.

It is, however, important to focus on some other aspects and achievements.

The FRIEND project, as implemented under the UNESCO - IHP, is not what we usually consider as a project organisation. With the very limited financial resources available from UNESCO, compared to the real costs involved in the execution of the various FRIEND projects, we may say that the projects are based on the common interest of the participating national institutions and individual scientists. We may therefore ask whether UNESCO plays any significant role in FRIEND ?

The answer is Yes. What UNESCO lacks in economic resources, the institution compensates in providing an international infrastructure which is fundamental. We may even suggest that an institution with great economic strength would never succeed in the establishment of a true co-operation between independent scientists and national scientific institutions in the way FRIEND has developed globally, with several new FRIEND projects around the globe. The first region to follow up was a second project in Southern Europe (AHMY). Then followed three projects in Africa (FRIEND Southern Africa; FRIEND Central and Western Africa; Nile Basin FRIEND), one in Southeast Asia and finally one or two FRIEND projects now starting on the American continent. Some of these projects have experienced some ups and downs during their period of operation. But the support from UNESCO and not to forget from some of the European countries and others, have enabled them to overcome the difficulties they have faced.

A second aspect is the positive and almost non-competitive relations UNESCO has with other UN organisations (WMO, FAO, IIASA, WHO, UNEP, a.o.) and non-governmental organisations such as IAHS, IWRA a.o., - organisations either working within the field of hydrology, or as dependent users of hydrological knowledge and understanding.

Each of the different regional FRIEND projects are developing their own working scheme according to the different needs and the research structures in their own region. We observe, however, that the links between the different FRIEND projects are developing in a fruitful manner, the family ties are becoming stronger and the benefit of exchange of studies, reports and scientists have been reported to be to the benefit for all involved parts.

After what has been said above about the achievements, is FRIEND only a success story? The answer is clearly No!

Funding of the research activities seems to be difficult to obtain both for the participating institutions and for individual scientists working within the framework of FRIEND. Even though we have observed very extreme climatological and hydrological events during the last decade, with enormous economical costs in property loss and repair of damaged constructions, reduced crop production, etc.,

it does not seem to have given more incentive among funding agencies to support basic hydrological research, research that would lead to improved process understanding which is necessary for a better societal planning based on value and risk assessments of natural systems. Neither FRIEND-NE nor AHMY have succeeded well with their application for to the European Union Framework III and IV programmes for funding of the ongoing research. It is, however, encouraging to learn that the World Bank has exposed an increased interest in promoting research activities in the water sector with concern to the developing regions of the world.

The challenges for FRIEND activities in the future should be along two different paths. The first, and the most important, is to enhance the scientific research and to strengthen the development of the network, between the scientists in each of the regional projects but also between the different project groups. It is, however, advisable that the different research groups consider to approach different owners of problems to formulate research objectives suited for societal planning purposes in their respective region. Such an approach might lead to more focus on water quality problems than has been that case up to now. An extension of the research scope into water quality problems has been discussed during the years, but has not achieved the necessary support to be included as yet. The pros for such an extension is, of course, to find wider interest in the results of the research; the cons are related to the even greater complexity of the problems and also increased difficulties regarding access to relevant data. Although water quality data are not officially restricted information in large parts of the world, not everybody is keen to expose what kind of pollution problems they have created in the past, - and at present.

The second path is to be more active in "marketing" the services hydrological science and research have to offer to the society. This means that hydrologists have to be more visible in society by participating more vividly in public discussions in newspapers and in other public media. We know that we have important knowledge and information that can be made better use of in our societies, - a gospel we preach when we are among ourselves at meetings, conferences, etc. But each of us are more or less invisible on the public scene. The public attention hydrologists will have in the future, and consequently access to funding, will depend on our ability to attract the interest of the decision makers. These people are controlling the keys to the treasury chests. These keys will be kept deep in their pockets if they are not convinced that the money they control are better used on hydrological research than on the alternatives presented to them.

Brève conclusion finale

Short final conclusion

P. Hubert

Le concept des projets FRIEND est né au moment où la communauté hydrologique internationale était secouée par de nombreuses interrogations concernant la nature de l'hydrologie, interrogations en particulier suscitées par les cinglantes réflexions de Vit Klemes. On a pu en effet alors constater que, trop souvent, l'hydrologie avait été pilotée par l'aval, c'est à dire par les besoins de l'ingénierie, et qu'elle n'avait pas su se fixer d'objectifs propres. Dans le même temps, et toujours parce qu'elle n'avait pas su explorer de nouveaux champs, l'hydrologie n'apportait que de médiocres contributions à la solution de problèmes pratiques nouveaux, en particulier ceux liés à la qualité de l'eau et à la gestion des milieux.

Ces critiques étaient sans doutes nécessaires mais ne suffisaient pas à elles seules à définir une perspective hydrologique dans le cadre des sciences de la terre. Certains hydrologues ont alors jeté tous leurs efforts dans l'étude des processus élémentaires. D'autres, et singulièrement les fondateurs du concept FRIEND, ont voulu développer une hydrologie régionale. Les deux approches, l'analytique et la synthétique, étaient sans doute nécessaires et se révéleront sûrement complémentaires à terme. La seconde, que le présent ouvrage entend illustrer, s'est cependant très rapidement révélée extrêmement féconde et apparaît aujourd'hui comme la réponse la plus achevée apportée par la communauté hydrologique internationale aux critiques, et autocritiques, qu'a subies sa discipline au cours des années quatre-vingts.

La première étape de tous les projets FRIEND est d'échanger et de faire circuler des données hydrologiques. Cela a bien entendu conduit à se préoccuper de leur qualité mais aussi à mieux saisir leur valeur. Quelques frilosités ont du être surmontées pour mettre en place un système de circulation des données tout à la fois efficace et respectueux des producteurs. Le cadre de l'UNESCO a été à cet égard précieux et la déontologie qui se dégage des projets FRIEND se révèle déjà utile dans d'autres cadres tels que le réseau européen des bassins versants expérimentaux, le Global Runoff Data Center, ou les différentes implémentations du projet WHYCOS de l'OMM. Cet apport de données nouvelles a élargi les perspectives des hydrologues qui ont pu sortir de "leur" bassin versant et travailler concrètement sur d'autres terrains, sous d'autres climats, sur d'autre régimes. Signalons enfin, et ce n'est pas la moindre des choses, que la constitution et la gestion des banques de données hydrologiques a aussi fait l'objet de recherches spécifiques d'un grand intérêt théorique et pratique.

Les projets FRIEND ont également amené les hydrologues à se mesurer aux problèmes d'échelles : échelles de temps, échelles d'espace mais aussi échelles de complexité. Ce n'est pas un hasard si ce thème est récurrent tout au long de cet ouvrage car, après avoir été très longtemps méprisé ou ignoré, il constitue véritablement aujourd'hui le coeur de l'hydrologie vivante. La prise de conscience de ce problème sonne le glas de certaines illusions naïves, celle du modèle à tout faire par exemple, mais elle ouvre aussi la voie à une méthodologie rationnelle d'usage de nos outils de recherche et de gestion, au premier rang desquels se trouvent les modèles mathématiques.

Les projets FRIEND ont enfin permis d'envisager une redéfinition des relations entre les exigences propres de la science hydrologique et la légitime demande sociale concernant l'eau et les milieux aquatiques. Ils auront en cela été, et continueront à être, utiles pour donner, selon une heureuse expression relevée dans ce rapport, une crédibilité sociale à l'hydrologie et une crédibilité scientifique à la gestion des eaux, ce qui constitue une bien belle et bien grande ambition pour tous les hydrologues.

ooooo

The FRIEND concept is born as the international hydrologist community was shaken up by a deep debate on what actually was the hydrological science, debate initiated, among others, by some cutting questions from Vit Klemes. It had then been clearly assessed that hydrology was too deeply driven by the engineering needs, and had too often neglected its own and proper scientific targets and stakes. In addition, and probably because such behaviour has restrained its capacity to address new and adequate fields, hydrology brought only low level answers for new arising questions, and contributed poorly to serve some very topical stakes like those concerning water quality or water bodies management.

Such criticisms were probably healthy, but they didn't give themselves clear and well defined prospects for a new future in hydrology, with a better interfacing toward other earth sciences. A majority of hydrologists put then all their energy on the elementary runoff processes analyses. A minority, and among them the FRIEND initiators, developed synthesis researches through regional approaches. Both are needed in hydrology, and their calling is to be complementary and interfaced. This synthesis domain and the regional hydrology, very largely concerned in the present report, appeared progressively as very fertile, and are now considered as very achieved answers brought by the hydrologist community to the previous criticisms, and self-criticisms, developed in the eighties.

A basic step in FRIEND is to make available, for exchanges and large spreading, sets of hydrological data. This needs to deal with their quality, and also to become more aware of their value. Various shivery behaviours, and sometimes blocks, needed to be overcome before settling data circulation procedures which were efficient enough for data users and respectful enough toward the data producer's constraints. The UNESCO umbrella for FRIEND was here very adequate and precious. The rules and code of ethics which arose inside the FRIEND framework for such data problems, brought a relevant contribution, useful and used in other domains or projects like the ERB network, the GRDC implementation, the WHYCOS regional structures, etc... The availability of such data sets allowed hydrologists to enlarge their viewpoints and prospects. They were pushed to come through their own basins and data, and to develop their concepts and models on other basins, other climates, and other regimes. As an added and non negligible contribution, these data exchanges implementations induced some specific researches on DBMS, which lead to very innovative results, serving both hydrological and information sciences.

FRIEND projects had also pushed hydrologists to tackle deeply the scale problems : not only for the classical time and space axes, but also with some innovative approaches, like scale problems arising along a (degree of) complexity axis, or along an analysis/synthesis one. This appears very frequently along this report. Too often ignored, or underestimated, these scale aspects are now one of the key question in hydrological modelling. A better awareness around them leads now hydrologists to leave their recent naïve dream of an universal hydrological model, and opens again new approach of a still diversified use of different mathematical models (this is not new), but now to be structured, clearly interfaced and scientifically validated (this is new), with a rational demonstration of the relevancy and adequacy of such needed diversification.

Finally, the FRIEND projects allowed to develop a deeply revised adequation and consistent redefinition of the links to be established between the proper needs and stakes, on one hand, internal to the hydrological science and, on the other hand, strongly developing in the social domain for water and water bodies management. So, FRIEND contributed, and will continue to contribute as it is happily mentioned in this report, to "a social credibility of hydrology and a scientific credibility of water management". Both are exciting ambitions for every hydrologist.

References of the chapter Conclusions

Références bibliographiques du chapitre Conclusion

AMIE1 (1994) : Analyse et Modélisation Intégrées du cheminement des Eaux en zones habitées - Application du concept PGEE à l'échelle du bassin versant. Rapport final du projet no 2176.1 de la Commission d'Encouragement pour la Recherche Scientifique (CERS). Ecole Polytechnique Fédérale de Lausanne.

Consuegra D. (1992) : Concept de gestion des eaux de surface, aspects méthodologiques et application au bassin versant de la Broye en Suisse. Thèse de doctorat, Ecole Polytechnique Fédérale de Lausanne.

Consuegra D., Vez E. (1996) : Modélisation hydrologique, application au bassin versant de la Haute Broye. Institut d'aménagement des terres et des eaux de l'Ecole Polytechnique Fédérale de Lausanne.

Dickinson R.E. (1992) : Role of soil and its hydrology. In "Climate system modeling", pp. 166-171, edited by Trenberth K.E., Cambridge University Press.

Dooge J.C.I., (1983): On the study of water. Hydrological Sciences Journal, 28, pp.23-48.

Dozier J., (1992): Opportunities to improve hydrologic data. Reviews of Geophysics, 30, pp.315-331

GIP HydroSystèmes (1994) : Du concept de BVRE à celui de Zone Atelier dans les recherches menés en eaux continentales. Séminaire national sur les BVRE, Paris, mai 1994. Cemagref Editions, 226 p.

Journal of Hydrology (1996) : Special issue on large hydrological system modelizations. Vol.175, 1-4.

Klemes V. (1986) : Dilettantism in hydrology - transition or destiny ? Wat. Resour. Res., 22 (9) : 177-188.

Rodda J.C., Pieyns S.A., Sehmi N.S., and Matthews G., (1993): Towards a world hydrological cycle observing system. Hydrological Sciences Journal, 38, pp.373-378.

Rodda J.C., (1995): Capturing the hydrological cycle. In: Time and the River, (G.W.Kite, Editor) Water Resources Publications, pp.25-58.

WMO., (1994): Guide to Hydrological Practices, 5th Edition. World Meteorological Organization, Geneva.

Authors and Chapter Editors

Auteurs et Editeurs de Chapitre

AFOUDA A., Association of African Hydrology - Université Nationale du Bénin - Département Mathématiques BP 526 Cotonou - Benin - Tél. : 229 32 16 79 Fax : 229 31 35 46

ANDERSSON L., Linköping University - Department of Theme Studies - Division of Geography 58183 Linköping - Sweden

ANDREWS A., Institute of Hydrology - Crowmarsh Gifford - Oxon OX10 8 bb Wallingford - United Kingdom - Tel. : 44 1 491 838 800 Fax : 44 1 491 692 424

ARDILES L., Centro de Estudios y Experimentación - Hidrología de sucesos extremos - Paseo Bajo de la Virgen del Puerto, 3 28005 Madrid - Spain - Tel. : 34 1 335 79 38 Fax : 34 1 335 79 22

ARNELL N., University of Southampton - Department of Geography - Highfield So17 1bj Southampton - United Kingdom - Tel. : 44 1 703 59 22 15 Fax : 44 1 703 59 32 95 n.w.arnell@soton.ac.uk

BAMBA F., Orstom - Antenne Hydrologique - 06 BP 1203 Cidex 1 Abidjan 06 - Côte d'Ivoire- Tel. : 225 45 00 74 Fax : 225 45 00 76

BENDJOUDI H., Laboratoire de Géologie Appliquée - Université Pierre et Marie Curie - 4 Place Jussieu - 75252 Paris cedex 05 - France - Tel. : 33 (0)1 44 27 63 26 Fax : 33 (0)1 44 27 51 25 hj@biogeodis.jussieu.fr

BERKHOFF C., Orstom - Antenne Hydrologique - 06 BP 1203 Cidex 1 Abidjan 06 - Côte d'Ivoire - Tel. : 225 45 00 74 Fax : 225 45 00 76

BERNTSEN E. University of Oslo - Faculty of Mathematics and Natural Sciences - P.O. Box 1032 Blindern 0315 Oslo - Norway - Tel. : 47 22 85 81 87 Fax : 47 22 85 63 39 einar.berntsen@matnat.uio.no

BEVEN K., Institute of Environmental and Biological Sciences - University of Lancaster - Bailrigg LA1 4YQ Lancaster - United Kingdom

BLAZKOVA S., T.G. Masaryk Water Research Institute - Podbabska 30 16062 Praha 6 - Czech Republic - Tel. : 42 2 20 197 204 Fax : 42 2 243 10 450 or 42 2 311 38 04

BOYER M., Orstom - Antenne Hydrologique - 06 BP 1203 Cidex 1 Abidjan 06 - Côte d'Ivoire - Tel. : 225 45 00 74 Fax : 225 45 00 76

BREIL P., Cemagref - Division Hydrologie - Hydraulique - 3 bis quai Chauveau CP 220 69336 Lyon Cedex 09 - France - Tel. : 33 (0)4 72 20 87 81 Fax : 33 (0)4 78 47 78 75 pascal.breil@cemagref.fr

BRICQUET J.P., Orstom - Antenne Hydrologique - 06 BP 1203 Cidex 1 Abidjan 06 - Côte d'Ivoire - Tel. : 225 45 00 74 Fax : 225 45 00 76

BRILLY M., Univ. of Ljubljana. Fac. of Architecture - Civil Eng. and Surveying, Hydraul. Dept. - Hajdrihova 28 1000 Ljubljana - Slovenia - Tel. : 386 61 12 64 288 Fax : 386 61 219 897 mbrilly@fagg.uni-lj.si

BULLOCK A., Institute of Hydrology - Oxon - OX10 8BB Wallingford - United Kingdom - Tel. : 44 1 491 838 800 Fax : 44 1 491 692 424 A. Bullock@unixa.nerc-wallingford.ac.uk

BULU A., Istanbul Technical Univ. - Civil Engineer. Faculty - Department of Hydraulics - 80 626 Maslak Istanbul - Turkey - Tel. : 90 212 285 37 35 Fax : 90 212 285 65 87 ou 90 212 285 37 10 bulu@sariyer.cc.itu.edu.tr

CHALISE S., Icimod - Mountain Environmental Management Division - P.O. Box 3226 Kathmandu - Nepal - Tel. : 977 52 53 13 ou 977 52 13 91 Fax : 977 1 52 45 09 ou 977 1 52 43 17

CLAUSEN B., Geologisk Institut - Aarhus Universitet - Ny Munkegade, Bygn 520 800 Aarhus C. - Denmark - Tel. : 45 89 42 36 39/28 99 Fax : 45 86 18 00 37 geombc@aau.dk

CONSUEGRA D., Ecole Polytechnique Fédérale de Lausanne (EPFL) - Dgr / Iate / Hydram - Gr - Ecublens 1015 Lausanne - Switzerland - Tel. : 41 21 693 37 25 (sec) Fax : 41 21 693 37 39

CZAMARA W., Agricultural University of Wroclaw - pl. Grunwaldzki 24 50-363 Wroclaw - Poland - Tel. : 48 71 205 518 Fax : 48 71 22 88 45

DAKOVA S., Institute of Meteorology and Hydrology - 66 Trakia Bul. - 1184 SOFIA - Bulgarie - Tel. : 359 2 72 22 71 Fax : 359 2 88 44 94 snejana.dakova@meteo.bg

DE ROOIJ G., Wageningen Agricultural University - Departement of Water Resources - Nieuwe Kanaal 11 6709 PA Wageningen - Netherlands - Tel. : 31 317 482778 / 482293 Fax : 31 317 484885

DEMUTH S., University of Freiburg - Institute of Hydrology - Werderring 4 79085 Freiburg - Germany- Tel. 49 761 20 33 538 Fax : 49 761 20 33 594 demuths@ruf.uni-freiburg.de

DESBOIS E., Cemagref - Division Hydrologie - Hydraulique - 3 bis quai Chauveau CP 220 69336 Lyon Cedex 09 - France - Tel. : 33 (0)4 72 20 87 97 Fax : 33 (0)4 78 47 78 75 elisabeth.desbos@cemagref.fr

DESUROSNE I., University Blaise Pascal - LAMP (Laboratoire de Météorologie Physique) - 24 avenue des Landais 63177 Aubière - France - Tel. : 33 (0)4 73 40 73 73 Fax : 33 (0)4 73 27 16 57 desurone@opgc.univ-bpclermont.fr

DEZETTER A., Orstom - 01 BP 182 Ouagadougou 01 - Burkina Faso

DIABATE M., Orstom - Antenne Hydrologique - 06 BP 1203 Cidex 1 Abidjan 06 - Côte d'Ivoire - Tel. : 225 45 00 74 Fax : 225 45 00 76

DIARRA M., Orstom - Antenne Hydrologique - 06 BP 1203 Cidex 1 Abidjan 06 - Côte d'Ivoire - Tel. : 225 45 00 74 Fax : 225 45 00 76

ELIAS V., Institute of Hydrodynamics - Academy of Sciences - Podbabska 13 16612 Praha 6 - Czech Republic

- FENDEKOVA M., Prifuk, pav. G - Department of Hydrogeology - Mlynska dolina 842 15 Bratislava - Slovakia - Tel. : 42 7 725 446 Fax : 42 7 725 446 podzvody@fns.uniba.sk
- FERRARI E., Universita della Calabria - Dipartimento difesa del suolo - S. Antonello Montalto uffugo scalo 87040 Cosenza - Italy - Tel. : 39 984 934316 / 937011 / 937012 Fax : 39 984 93 42 45 ferrari@dssserver.unical.it
- FERRER J., Ministerio de obras públicas - Servicio de Hidrología - Confederación hidrográfica del Júcar - Avda Blasco Ibañez, 48 46010 Valencia - Spain - Tel. : 34 96 393 89 60 Fax : 34 96 393 88 01
- FRITSCH J.-M., Orstom - Laboratoire d'Hydrologie - 911 avenue Agropolis BP 5045 34032 Montpellier Cedex 1 - France - Tel. : 33 (0)4 67 41 61 00 Fax : 33 (0)4 67 41 18 06 fritsch@orstom.rio.net
- GALEA G., Cemagref - Division Hydrologie-Hydraulique - 3 bis quai Chauveau CP 220 69336 Lyon Cedex 09 - France - Tel. : 33 (0)4 72 20 87 73 Fax : 33 (0)4 78 47 78 75 gilles.galea@cemagref.fr
- GILARD O., Cemagref - Division Hydrologie - Hydraulique - 3 bis quai Chauveau CP 220 69336 Lyon Cedex 09 - France - Tel. : 33 (0)4 72 72 87 64 Fax : 33 (0)4 78 47 78 75 olivier.gilard@cemagref.fr
- GIVONE P., Cemagref - Division Hydrologie - Hydraulique - 3 bis quai Chauveau CP 220 69336 Lyon Cedex 09 - France - Tel. : 33 (0)4 72 20 87 69 Fax : 33 (0)4 78 47 78 75 pierrick.givone@cemagref.fr
- GOTTSCHALK L., University of Oslo - Department of Geophysics - P.O. Box 1022 Blindern 0135 Oslo - Norway - Tel. : 47 22 85 58 09 (58 23) Fax : 47 22 85 52 69 lars.gottschalk@geofysikk.uio.no
- GUSTARD A., Institute of Hydrology - Maclean building. Crowmarsh Gifford P.O. Box10 8bb Wallingford - United Kingdom - Tel. : 44 1 491 838 800 Fax : 44 1 491 692 424 friend@ua.nwl.ac.uk OU a.gustard@ioh.ac.uk
- HERRMANN A., Technische Universitat Braunschweig - Physische Geographie und Hydrologie - Langer kamp 19c 38106 Braunschweig - Germany - Tel. : 49 531 391 5607 or 5606 Fax : 49 531 391 8170 herrmann@ifgug.nat.tu-bs.de
- HOLKO L., Institute of Hydrology SAS - Experimental Hydrological Base - Ondrasovecka 16 03105 Liptovsky mikulas - Slovakia
- HUBERT P., École nationale supérieure des mines de Paris - Centre d'Informatique Géologique - 35 rue Saint Honoré 77305 Fontainebleau - France - Tel. : 33 (0)1 64 69 47 40 Fax : 33 (0)1 64 69 47 03 hubert@cig.ensmp.fr
- IIRITANO G., Universita della Calabria - Dipartimento difesa del suolo - S. Antonello Montalto Uffugo Scalo - 87040 Cosenza - Italy - Tel. : 39 984 934 316 Fax : 39 984 934 245 iiritano@dssserver.unical.it
- KACHROO R., University of Dar es Salaam - Department of Civil Engineering - P.O. Box 35 131 Dar es Salaam - Tanzania - Fax : 255 51 43 029
- KASPAREK L., T.G. Masaryk Water Research Institute - Podbabska 30 16062 Praha 6 - Czech Republic - Tel. : 42 220 197 227 Fax : 42 243 10 450 Kasperek@vuz.cz
- KOLAROVA S., T.G. Masaryk Water Research Institute - Podbabska 30 16062 Praha 6 - Czech Republic - Tel. : 42 2 20 197 204 Fax : 42 2 243 10 450
- KOUAME B., Orstom - Antenne Hydrologique - 06 BP 1203 Cidex 1 Abidjan 06 - Côte d'Ivoire - Tel. : 225 45 00 74 Fax : 225 24 65 04/45 00 76
- KRASOVSKAIA I., Hydroconsult AB - Lergravsvn 33 263 52 Höganäs - Sweden
- KUPSZYK E., Pedagogical University Kielce - c/o Warsaw University - Lazurowa 4/61 P.O. Box 11 01-315 Warszawa - Poland - Tel. : 48 22 200 381 Fax : 48 22 261 965
- LANG M., Cemagref - Division Hydrologie - Hydraulique - 3 bis quai Chauveau - CP 220 69336 Lyon Cedex 09 - France - Tel. : 33 (0)4 72 20 87 60 Fax : 33 (0)4 78 47 78 75 michel.lang@cemagref.fr
- LARAQUE A., Orstom - Antenne Hydrologique - 06 BP 1203 Cidex 1 Abidjan 06 - Côte d'Ivoire- Tel. : 225 45 00 74 Fax : 225 45 00 76
- LEBLOIS E., Cemagref - Division Hydrologie - Hydraulique - 3 bis quai Chauveau CP 220 69336 Lyon Cedex 09 - France - Tel. : 33 (0)4 72 72 87 89 Fax : 33 (0)4 78 47 78 75 etienne.leblois@cemagref.fr
- LEPISTO A., Finnish Environment Agency - P.O. Box 140 Fin-00251 Helsinki - Finland - Tel. : 358 9 403 00 458 Fax : 358 9 403 00 490 ahti.lepisto@vyh.fi
- LEROUX J.F., Orstom - Antenne Hydrologique - 06 BP 1203 Cidex 1 Abidjan 06 - Côte d'Ivoire - Tel. : 225 45 00 74 Fax : 225 45 00 76
- LLASAT C., Univ. de Barcelona - Facultad de Física - Deptº de astronomía y meteorología - Avda. diagonal 647 08028 Barcelona - Spain - Tel. : 34 3 402 11 33 Fax : 34 3 402 11 24 carmell@mizar.am.ub.es ou carmen@facllb0.am.ub.es
- LUBES-NIEL H., Orstom - Laboratoire d'hydrologie - 911 avenue Agropolis BP 5045 34032 Montpellier Cedex 1 - France - Tel. : 33 (0)4 67 61 74 00 Fax : 33 (0)4 67 41 18 06
- MAHE G., Orstom - Antenne Hydrologique - 06 BP 1203 Cidex 1 Abidjan 06 - Malawi - Tel. : 225 45 00 74 Fax : 225 45 00 76
- MAJERCAKOVA O., Slovak Hydrometeorological Institute - Department of Hydrological Research - Jeseniova 17 833 15 Bratislava - Slovakia - Tel. : 7 373 929 Fax : 7 376 562/374 927
- MANEA A., Cemagref - Division Hydrologie - Hydraulique - 3 bis quai Chauveau CP 220 69336 Lyon Cedex 09 - France - Tel. : 33 (0)4 72 72 87 68 Fax : 33 (0)4 78 47 78 75 manea@lyon.cemagref.fr
- MATREATA M., National Institute of Meteorology and Hydrology - Sos bucuresti-ploiesti 97 - sector 1 71552 Bucarest - Romania - Tel. : 40 1 633 45 07 Fax : 40 1 23 03 143
- MIC R., National Institute of Meteorology and Hydrology - Sos bucuresti-ploiesti 97 - sector 1 71552 Bucarest - Romania - Tel. : 40 1 633 45 07 Fax : 40 1 23 03 143
- MIKLANEK P., Institute of Hydrology SAS - Racianska 75 PO Box 94 830 08 Bratislava 38 - Slovakia - Tel. : 427 259 311 Fax : 427 259 311 ncihp@uh.savba.skdr
- MKHANDI S., University of Dar es Salaam - Department of Civil Engineering - P.O. Box 35 131 Dar es Salaam - Tanzania - Fax : 255 51 43 029
- MNGODO R., University of Dar es Salaam - Department of Civil Engineering - Po box 35 131 Dar es Salaam - Tanzania- Tel. : 255 51 43 501/43029 Fax : 255 51 43 029/46757

NOVICKY O., TGM Water Research Institute - Podbabska 30 - 16062 Praha 6 - Czech Republic.

OANCEA V., Massachusetts Institute of Technology - Earth Resources Laboratory - 42 Carleton Street - Bldg. E34- Ma 02142 Cambridge - United States - Fax : 1 617 253 6385 oancea@erl.mit.edu.us

OBERLIN G., Cemagref - Division Hydrologie - Hydraulique - 3 bis quai Chauveau 69336 Lyon Cedex 09 - France - Tel. : 33 (0)4 72 20 87 72 Fax : 33 (0)4 78 47 78 75 guy.oberlin@cemagref.fr

OLIVRY J.-C., Orstom - BP 5045 34032 Montpellier Cedex - France - Tel. : 33 (0)4 67 41 62 27 Fax : 33 (0)4 67 41 18 06 J-Claude.Olivry@mpl.orstom.fr

ORANGE D., Orstom - Antenne Hydrologique - 06 BP 1203 Cidex 1 Abidjan 06 - Côte d'Ivoire - Tel. : 225 45 00 74 Fax : 225 45 00 76

PATUREL J.E., Orstom - Antenne Hydrologique - 06 BP 1203 Cidex 1 Abidjan 06 - Côte d'Ivoire - Tel. : 225 45 00 74/45 41 70 Fax : 225 45 00 76/24 65 04 paturel@orstom.rio.net

PETROVIC J., Faculty of Civil Engineering - University of Belgrade P.O. Box 895 11000 Belgrade - Yugoslavia - Tel. : 381 11 322 91 90 Fax : 381 11 322 02 37

PRUDHOMME C., Institute of Hydrology - Maclean Building. Crowmarsh Gifford - P.O. Box10 8bb Wallingford - United Kingdom - Tel. : 44 1 491 838 800 Fax : 44 1 491 692 424

RADIC Z., Faculty of Civil Engineering - Bul. revolucije 73 11000 Belgrade - Yugoslavia - Tel. : 381 11 3229 190/212/260 Fax : 381 11 3220 237

RADSUK L., Agricultural University of Wroclaw - pl. Grunwaldzki 24 50-363 Wroclaw - Poland - Fax : 048 71 22 88 45

REES G., Institute of Hydrology - Maclean building Crowmarsh Gifford Ox10 8bb Wallingford - Oxon - United Kingdom - Tel. : 44 1 491 838 800 Fax : 44 1 491 692 424 grees@ua.nwl.ac.uk / g.rees@unixa.nerc-wallingford.ac.uk.

RODDA J., AISH - Institute of Hydrology - Maclean Building. Crowmarsh Gifford Ox10 8bb Wallingford - United Kingdom - Tel. : 44 1 491 838 800 Fax : 44 1 491 692 424

SAKHO M., Sous-directeur de l'hydrologie - BP v. 83 Abidjan - Côte d'Ivoire - Tel. : 225 22 77 19 Fax : :225 21 11 20 sakho@hydro.gire.ci

SAUQUET E., Cemagref - Division Hydrologie - Hydraulique - 3 bis quai Chauveau CP 220 69336 Lyon Cedex 09 - France - Tel. : 33 (0)4 72 72 87 86 Fax : 33 (0)4 78 47 78 75 sauquet@lyon.cemagref.fr

SERVAT E., Orstom - Antenne Hydrologique - 06 BP 1203 Cidex 1 Abidjan 06 - Côte d'Ivoire - Tel. : 225 45 41 70 Fax : 225 45 68 29 servat@adiopo.orstom.ci

SEUNA P., Finnish Environment Agency - P.O. Box 140 00251 Helsinki - Finland - Tel. : 358 9 403 00 323 Fax : 358 9 403 00 391 pertti.seuna@vyh.fi

SHORTHOUSE C., University of Southampton - Department of geography - Highfield o17 1bj Southampton - United Kingdom - Tel. : 44 1 703 59 22 15 Fax : 44 1 703 59 32 95

SIR M., Institute of Hydrodynamics - Academy of Sciences - Podbabska 13 16612 Praha 6 - Czech Republic

SOU MAGUEL A., Orstom - Antenne Hydrologique - 06 BP 1203 Cidex 1 Abidjan 06 - Côte d'Ivoire- Tel. : 225 45 00 74 Fax : 225 45 00 76

STANESCU V. A., National Institute of Meteorology and Hydrology - - Sos bucuresti-ploiesti 97 - secteur 1 71552 Bucarest - Romania - Tel. : 40 1 633 45 07 Fax : 40 1 23 03 143 stanescu@meteo.inmh.ro

SZOLLOSI - NAGY A., Unesco - Division des Sciences de l'Eau - 7 place de Fontenoy 75700 Paris - France - Tel. : 33 (0)1 45 68 39,99 Fax : 33 (0)1 45 67 58 69 a.szollosi-nagy@unesco.org

TALLAKSEN L., University of Oslo - Department of Geophysics - P.O. Box 1022 Blindern 0315 Oslo - Norway - Tel. 47 22 85 72 14 Fax : 47 22 85 52 69 lena.tallaksen@geofysikk.uio.no

TESAR M., Institute of Hydrodynamics - Academy of Sciences - Podbabska 13 16612 Praha 6 - Czech Republic

UNGUREANU V., National Institute of Meteorology and Hydrology - Sos bucuresti-ploiesti 97 - secteur 1 71552 Bucarest - Romania - Tel. : 40 1 633 45 07 Fax : 40 1 23 03 143

VAN DEN EERTWEGH G.A.P.H., Wageningen Agricultural University - Departement of Water Resources - Nieuwe Kanaal 11 6709 PA Wageningen - Netherlands - Tel. : 31 317 482778 / 482293 Fax : 31 317 484885

VAN DER WATEREN-DE HOOG B., University of Utrecht - Department of Physical Geography - Netherlands

VAN LANEN H., Wageningen Agricultural University - Department of Water Resources - Nieuwe Kanaal 11 6709 PA Wageningen - Netherlands - Tel. : 31 317 48 24 18 Fax : 31 317 48 48 85 henny.vanlanen@users.whh.wau.nl

VERSACE P., Universita della Calabria - Dipartimento di difesa del suolo - C. da s. antonello 87040 Montalto uffugo scalo (cs) - Italy - Tel. : 39 984 934 316 - 937011-2 Fax : 39 984 934 245 versace@dssserver.unical.it

VEZ E., Ecole Polytechnique Fédérale de Lausanne (EPFL) - Dgr / Iate / Hydram - Gr - Ecublens 1015 Lausanne - Switzerland - Tel. : 41 21 693 37 25 (sec) / 31 (direct) Fax : 41 21 693 37 39 eric.vez@dgr.epfl.ch

VUKMIROVIC V., Faculty of Civil Engineering - Bul. revolucije 73 P.O. Box 895 11000 Belgrade - Yugoslavia - Tel. : 381 11 322 91 90 ou 381 11 322 66 67 Fax : 381 11 322 0237 vukmir@hidro.fcivbg.yu/ paveovd@ubbg.etf.bg.ac

WARMERDAM P., Wageningen Agricultural University - Departement of Water Resources - Nieuwe Kanaal 11 6709 PA Wageningen - Netherlands - Tel. : 31 317 482778 / 482293 Fax : 31 317 484885

ZEBIDI H., Unesco. - Division des Sciences de l'Eau - 1 rue Miollis 75015 Paris - France - Tel. : 33 (0)1 45 68 39 98 Fax : 33 (0)1 45 68 58 11 h.zebidi@unesco.org

LOUIS - J E A N
avenue d'Embrun, 05003 GAP cedex
Tél. : 04.92.53.17.00
Dépôt légal : 576 — Juillet 1997
Imprimé en France

FRIEND — Flow Regimes from International Experimental and Network Data

Projects H-5-5 (IHP IV) and 1.1 (IHP V)

Third report : 1994-1997

• Ce rapport présente une sélection des travaux menés dans FRIEND pendant la période 1994-1997. C'est le troisième rapport quadriennal pour ce projet du PHI de l'UNESCO. Il traite des principaux thèmes concernant les régimes hydrologiques des rivières, abordés selon des méthodes régionales : bases de données, apports étiages, crues, fortes pluies, processus physiques d'écoulements, tendances, hydrologie de la gestion intégrée des eaux. Quelques informations sont données sur l'implantation de FRIEND, ses Groupes et son histoire. Un essai de prospective est fait pour l'avenir du projet, mais aussi pour celui de l'hydrologie régionale et pour sa place dans l'ensemble de l'hydrologie ; Les aspects internationaux de l'hydrologie, y compris le fonctionnement en réseau de la recherche menée dans FRIEND, sont également présentés. Leurs avantages, ainsi que leurs conditions de succès, sont discutés. Ce rapport s'adresse aux hydrologues et gestionnaires de l'eau, ainsi qu'aux scientifiques et spécialistes de l'environnement qui s'occupent occasionnellement de rivières.

• A selection of the FRIEND activities during the period 1994-1997 is presented in this third general four-year report for that UNESCO IHP project. The river hydrological regimes are mainly dealt, together with their main topics, and tackled through regional approaches : data bases, runoffs, low flows, floods, heavy rains, physical basis of runoff, trends, hydrology of the water management. Some information are given on the FRIEND implementation, its Groups and its history. An attempt of prospective is suggested for the future of the project, for regional hydrology, and for its place in hydrology in general. The international aspects of hydrology, including the network way of research as undertaken in FRIEND, are also presented. Their advantages, together with the conditions for success, are discussed. The report aims at hydrologists, water resources managers, and scientists or environmental managers who deal sometimes with rivers.



HydrOsystèmes



Cemagref



ISBN 2-85362-475-3

9 782853 624756

Prix : 390 FF